

Contents

Thermoforming[®] QUARTERLY

TECHNICAL SECTION

Lead Technical Article:

Enhanced TPO Thermoforming Using High Melt Strength Polyolefin Elastomers.... 10

Industry Practice:

Collaborative and Methodical Development Reduces Time From Concept to Production 15

Industry Practice:

Proper Colleting and Collet Maintenance in CNC Routing of Plastic 16

Industry Practice:

History of Thermoforming – Part I 19

Thermoforming 101:

Understanding How a Sheet Stretches 22

Book Review:

The Evolution of Plastics in America (As Seen Through the National Plastics Expositions) 24

DIVISION ACTIVITIES

Chairman's Corner Inside Front Cover

Membership Memo: It's Conference Time Again! 2

New Members 3

Thermoformer of the Year 2006 Nomination Form 7

Milwaukee Board Meeting Schedule 8

Council Report 26

Membership Application 33

Index of Sponsors 36

Board of Directors List Inside Back Cover

These sponsors enable us to publish **Thermoforming Quarterly**

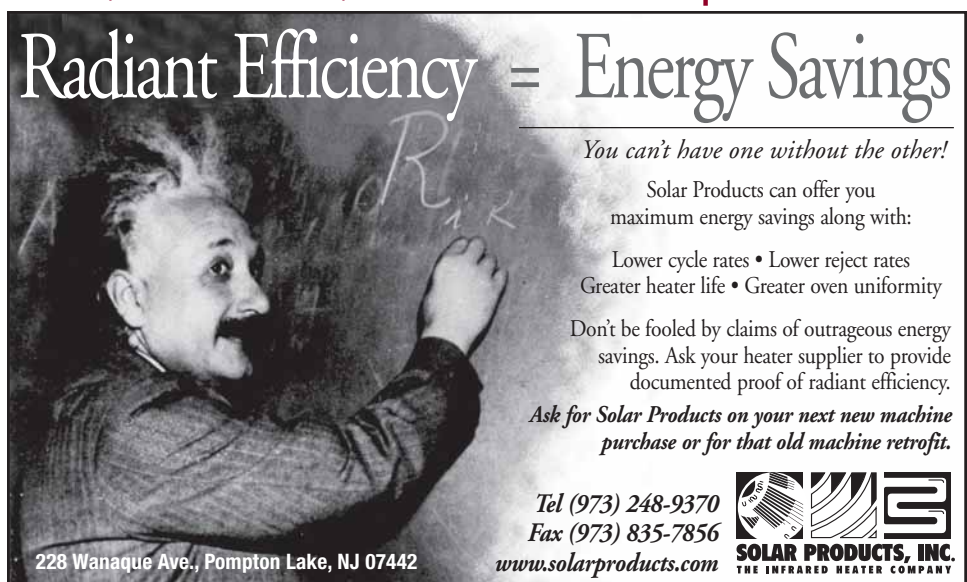

Radiant Efficiency = Energy Savings

You can't have one without the other!

Solar Products can offer you maximum energy savings along with:

- Lower cycle rates • Lower reject rates
- Greater heater life • Greater oven uniformity

Don't be fooled by claims of outrageous energy savings. Ask your heater supplier to provide documented proof of radiant efficiency.

Ask for Solar Products on your next new machine purchase or for that old machine retrofit.

Tel (973) 248-9370
Fax (973) 835-7856
www.solarproducts.com



SOLAR PRODUCTS, INC.
THE INFRARED HEATER COMPANY

228 Wanaque Ave., Pompton Lake, NJ 07442

A NOTE TO PROSPECTIVE AUTHORS

TFQ is an "equal opportunity" publisher! You will note that we have several categories of technical articles, ranging from the super-high tech (sometimes with equations!), to industry practice articles, to book reviews, how to articles, tutorial articles, and so on. Got an article that doesn't seem to fit in these categories? Send it to Jim Throne, Technical Editor, anyway. He'll fit it in! He promises. [By the way, if you are submitting an article, Jim would appreciate it on CD-ROM in DOC format. All graphs and photos should be black and white and of sufficient size and contrast to be scannable. Thanks.]

Thermoforming[®] QUARTERLY

A JOURNAL PUBLISHED EACH CALENDAR QUARTER BY THE THERMOFORMING DIVISION OF THE SOCIETY OF PLASTICS ENGINEERS

Editor

Gwen Mathis

(706) 235-9298 • Fax (706) 295-4276
gmathis224@aol.com

Technical Editor

Dr. James Throne

Sherwood Technologies, Inc.
1797 Santa Barbara Drive
Dunedin, FL 34698-3347
1-800-273-6370 • Fax (727) 734-5081
throne@foamandform.com
jthrone@tampabay.rr.com

Sponsorships

Laura Pichon

(815) 678-2131 Ext. 624
Fax (815) 678-4248

lpichon@extechplastics.com

Thermoforming Quarterly® is published four times annually as an informational and educational bulletin to the members of the Society of Plastics Engineers, Thermoforming Division, and the thermoforming industry. The name, "Thermoforming Quarterly®" and its logotype, are registered trademarks of the Thermoforming Division of the Society of Plastics Engineers, Inc. No part of this publication may be reproduced in any form or by any means without prior written permission of the publisher, copyright holder. Opinions of the authors are their own, and the publishers cannot be held responsible for opinions or representations of any unsolicited material. Printed in the U.S.A.

Thermoforming Quarterly® is registered in the US Patent and Trademark Office (Registration no. 2,229,747).

It's Conference Time Again!



BY MIKE SIROTNAK, MEMBERSHIP CHAIRMAN

The last time our conference was held in the beautiful city of Milwaukee, our country was still reeling from the devastating attacks of 9/11. I will never forget having to drive from New Jersey to Milwaukee, due to the massive airport closings, wondering what the future would hold. Now four years later, it's hard not to think back on that time and reflect on how much has changed and remarkably how much has stayed the same. I am very proud of our members for their continued support and I am confident that our division will achieve all of its goals.

Just a reminder! The reprints of our very first DVD "What is Thermoforming?" have arrived and are available. Please feel free to contact any of the Board members to request additional copies or visit our website, www.thermoformingdivision.com, for more information.

Recently the Thermoforming Division donated money to sup-

port a group of doctors and nurses to visit Sri Lanka to aid in the Tsunami relief. Make sure to read the article in this issue for complete details. It's another example of the good works your membership provides. Scholarships, educational equipment

gram will be cutting edge with a focus on new technology in our industry. Walt Walker and Ed Probst have searched high and low to bring you all that is new. The exhibit floor will be bigger and better than ever. Try to make a point of spending as much time as possible on the exhibit floor. The exhibitors are the backbone of these conferences. Joe Peters has put together a very diverse Parts Competition. Make sure to stop by and see what your competitors are up to. This year we are offering four plant tours including topnotch processors, Prent Corp. and Profile Plastics. You have to respect those business leaders that allow

the public to visit their facilities. Steve Murrill and Walt Walker are two examples of our industry's best. Four years ago, Milwaukee did not see our best. Let's make sure this conference changes that. See you on the exhibit floor.

God Bless America!



MEMBERSHIP REPORT as of 6/15/05

Primary Paid	1,229
Secondary Paid	447
Total Membership	1,726
Goal as of 6/30/2005	2,000

grants, disaster relief donations, educational DVD's, *Thermoforming Quarterly*, technical conference and the only industry specific trade show ... all possible because of your continued support. I urge you to continue to help recruit new members.

This year's conference should be very exciting. Hometown boy, Bob Porsche, has put together an exciting conference. The technical pro-



To Our New Members

Philip Allgood
MEI
Smyrna,
Georgia

Jeff Bostic
Three Four
Solutions
LLC
Bammamish,
Washington

James L.
Cameron
Barron &
Rowson Ply
Ltd.
Australia

Euclide
Cecchin
Omega Tool Ltd.
Warren,
Michigna

Ray Collins
Anchor Plastics
Machinery
Ltd.

United
Kingdom

Don Gerhardt
Ingersoll Rand
Clemmons,
North
Carolina

Sheila Greer
Benver State
Plastics
Drain, Oregon

Kenneth Herold
Rotocast
Technologies
Akron, Ohio

Don Hexamer
Tri City
Packaging
Waterloo,
Canada

Ken A. Hopkins
Allen, Texas

Daniel W. King
Copley, Ohio

Young Soo Ko
Borealls
Polymers Co.
Finland

Fernando Lemos
Jay Packaging
Group
Warwick, Rhode
Island

John Luscombe
Integrated
Composite
Technologies
Montezuma,
Georgia

Charles Mans
Azimuth
Custom
Extrusions
LLC
Evansville,
Indiana

Gary Mantyla
Plast-Labs, Inc.
Lansing,
Michigan

Dick Marr
Genpak LLC
Holyoke,
Massachusetts

Mark McKaig
Genpak LLC
Montgomery,
Alabama

William Moore
Ballwin,
Missouri

John Mosher
The Boxboro
Group
Boxboro,
Massachusetts

Charles A.
Munson
American Pipe
& Plastics,
Inc.
Binghamton,
New York

Trevor
Nickerson
PCF/Jamestown
Plastics
Mayville, New
York

Fred Ollarsaba
Tempe, Arizona

Thomas Schein
All About
Packaging,
Inc.
Appleton,
Wisconsin

Shankara
Shettym
Concept
Management
Company
St. Simons
Island,
Georgia

Ryan Snow
All About
Packaging,
Inc.
Appleton,
Wisconsin

Harinder S.
Tamber
Tambar
Consultants
Mississauga,
Ontario -
Canada

Charles Tutty
CJK
Manufacturing
LLC
Rochester, New
York

Tim Tutty
CJK
Manufacturing
LLC
Rochester, New
York

Keith
Woodward
CJK
Manufacturing
LLC
Rochester, New
York

Jim Zubersky
TPI
White Bear
Lake,
Minnesota

WHY JOIN?

It has never been more important to be a member of your professional society than now, in the current climate of change and volatility in the plastics industry. Now, more than ever, the information you access and the personal networks you create can and will directly impact your future and your career.

Active membership in SPE:

- keeps you current
- keeps you informed
- keeps you connected

The question really isn't "why join?" but ...

WHY NOT?

THERMOFORMING QUARTERLY ... A WINNER!



At the recent Antec in Boston, the Thermoforming Quarterly again won First Place in the Division's Newsletter Contest. Roger Kipp, Division Chairman, is shown presenting the award to the Thermoforming Quarterly Editor Gwen Mathis.

These sponsors enable us to publish **THERMOFORMING QUARTERLY**

PLC PLASTIC CONCEPTS & INNOVATIONS LLC

Guiding Innovations in the Development and Production of Thermoformed Products

PRESENTS:

MOVING BEYOND THE BASICS

A TWO DAY SEMINAR ON ADVANCED HEAVY GAUGE THERMOFORMING

DESIGNED TO PROVIDE AN IN-DEPTH LOOK AT
ALL ASPECTS OF THE THERMOFORMING PROCESS
WHILE HIGHLIGHTING ADVANCED MATERIALS

WHEN		WHERE
JUNE	14-15	LAND INSTRUMENTS, NEWTOWN, PA
JULY	19-20	PORTAGE CASTING & MOLDS, PORTAGE, WI
AUG	16-17	COMFORT SUITES, ELKHART, IN
OCT	18-19	STOPOL/BERTRAM INN AURORA OH
OCT	25-26	SOUTHTECH PLASTICS, NEW BERN NC
NOV	15-16	SOLVAY ENG. POLYMERS, MANSFIELD TX
DEC	13-14	PRIMEX OAKWOOD PLANT, ATLANTA GA

COST: \$395.00 PER PERSON:

INCLUDES INSTRUCTIONAL MATERIALS AND REFRESHMENTS

COURSE OUTLINE, REGISTRATION FORMS AND SPONSORS AT

WWW.PLASTICCONCEPTS.COM

In Memory of James E. Gilham



On April 27, 2005, James E. Gilham of Marlton, New Jersey passed away at the age of 78. He was the beloved husband for 50 years to the late Doris E. (nee Homan). Loving father of Harold S. Gilham and his wife Lisa of Southampton, NJ; Deborah Cherico and her husband John of St. Louis Park, MN; Robin Zerillo and her husband John of Medford, NJ; Lorrie Fabrizio and her husband Joseph of West Chester, PA; and 14 grandchildren. Dear brother of Mimi Leisy, Betty Danley, Tom Gilham and Butch Gilham. A service honoring his life was held at St. Andrew's Methodist Church with interment in Locustwood Memorial Park, Cherry Hill, NJ. Contributions in his memory may be made to the Lupus Foundation of South Jersey, 1873 Rt. 70 East, Cherry Hill, NJ 08003. ■

PENN STATE-ERIE ROOMMATES RECEIVE 2005 THERMOFORMING SCHOLARSHIPS

Ken Griep, Chairman of Student Affairs, is pleased to announce the winners of the following scholarships. These scholarships will be presented during the annual Thermoforming Conference in Milwaukee.

JOHN GRIEP MEMORIAL \$5,000.00 SCHOLARSHIP

TRAVIS HUNTER
PENN STATE - ERIE



Travis Hunter is a Senior at Penn State-Erie majoring in Plastics Engineering Technology. He has had extensive experience with the thermoforming process and is currently completing a project that tests the thermoformability of four different polymers (HDPE, LDPE, PP and PET) with additives. In an earlier project, he used an epoxy compound to form a mold of a product that is already on the market and tested the permeability properties of the thermoformed polymer. Travis had an internship at Emerson Appliance Controls where he was able to design a new mold. The Manager of Engineering at Emerson indicated that Travis and his partner, Joshua Sindlinger, were the best interns he'd worked with in his 35 years with the company. ■

SEGEN MEMORIAL \$5,000.00 SCHOLARSHIP

JOSHUA SINDLINGER
PENN STATE - ERIE



Joshua Sindlinger is a Senior at Penn State-Erie majoring in Plastics Engineering Technology. He has had extensive experience with the thermoforming process and is currently completing a project that tests the thermoformability of four different polymers (HDPE, LDPE, PP and PET) with additives. Josh partnered with his PS-E roommate Travis Hunter at Emerson Appliance Controls. Josh also worked for Holbrook Tool as an injection molding machine operator in the summer of 2000. Upon graduation, he hopes to become a process engineer and then work his way up the corporate ladder. ■

These sponsors enable us to publish **THERMOFORMING QUARTERLY**

POLYPROPYLENE. PET. CPET.

Three more reasons to choose Lyle Thermoforming Equipment.

From high-speed polystyrene to custom form-trim-stack operations or wide-bed polypropylene jobs, you don't have to settle for less than a Lyle. Call 989-435-7717 for details, or visit our web site: www.lyleindustries.com.

LYLE
THERMOFORMING EQUIPMENT
4144 W. Lyle Road ■ Beaverton, MI 48612

SALZBURG - AUSTRIA
17-18 MARCH 2006

5th EUROPEAN THERMOFORMING CONFERENCE 2006

Market Development
through Innovation

europ an
thermoforming
division

THERMOFORMER OF THE YEAR

CRITERIA FOR 2006

Every year The SPE Thermoforming Division selects a individual who has made a outstanding contribution to our industry and awards them the Thermoformer of the Year award.

The award in the past has gone to industry pioneers like Bo Stratton and Sam Shapiro, who were among the first to found thermoforming companies and develop our industry. We have included machine designers and builders Gaylord Brown and Robert Butzko and toolmaker John Greip, individuals who helped develop the equipment and mold ideas we all use today. We have also honored engineers like Lew Blanchard and Stephen Sweig, who developed and patented new methods of thermoforming. Additionally, we have featured educators like Bill McConnell, Jim Throne and Herman R. Osmer, who have both spread the word and were key figures in founding the Thermoforming Division.

We're looking for more individuals like these and we're turning to the Thermoforming community to find them. Requirements would include several of the following:

- Founder or Owner of a Thermoforming Company
- Patents Developed
- Is currently active in or recently retired from the Thermoforming Industry
- Is a Processor – or capable of processing
- Someone who developed new markets for or started a new trend or style of Thermoforming
- Significant contributions to the work of the Thermoforming Division Board of Directors

➤ Has made a significant educational contribution to the Thermoforming Industry.

If you would like to bring someone who meets some or all of these requirements to the attention of the Thermoforming Division, please fill out a nomination form and a one-to-two-page biography and forward it to:

Thermoforming Division Awards Committee

% Productive Plastics, Inc.

Hal Gilham

103 West Park Drive

Mt. Laurel, NJ 08045

Tel: 856-778-4300

Fax: 856-234-3310

Email:

halg@productiveplastics.com

You can also find the form and see all the past winners at www.thermoformingdivision.com in the Thermoformer of the Year section.

You can submit nominations and bios at any time but please keep in mind our deadline for submissions is no later than December 1st of each year, so nominations received after that time will go forward to the next year.

These sponsors enable us to publish **THERMOFORMING QUARTERLY**

**STRONGER
THAN
EVER**

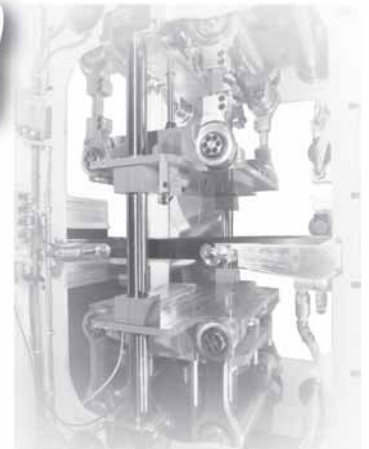

IRWIN

Research & Development, Inc.

THERMOFORMERS | GRINDERS | TOOLING

Phone: 509-248-0194 www.irwinresearch.com

Thermoformers of the Year ...

1982

William K. McConnell, Jr.
McConnell Company

1983

E. Bowman Stratton, Jr.
Auto-Vac Corp.

1984

Gaylord Brown
Brown Machine

1985

Robert L. Butzko
Thermtrol Corp.

1986

George Wiss
Plastofilm Industries

1987

Dr. Herman R. Osmers
Educator & Consultant

1988

Robert Kittridge
Fabri-Kal Corporation

1989

Jack Pregont
Prent Corporation

1990

Ripley W. Gage
Gage Industries

1991

Stanley Rosen
Mold Systems Corp.

1992

Samuel Shapiro
Maryland Cup
Sweetheart Plastics

1993

John Grundy
Profile Plastics

1994

R. Lewis Blanchard
Dow Chemical

1995

James L. Blin
Triangle Plastics

1996

John Griep
Portage Casting & Mold

1997

John S. Hopple, Hopple Plastics

1998

Lyle Shuert, Shuert Industries

1999

Art Buckel
McConnell Company

2000

Dr. James Throne
Sherwood Technologies

2001

Joseph Pregont, Prent Corp.

2002

Stephen Sweig, Profile Plastics

2003

William Benjamin,
Benjamin Mfg.

2004

Steve Hasselbach, CMI Plastics

THERMOFORMER OF THE YEAR 2006

Presented at the September 2006 Thermoforming Conference in Nashville, Tennessee

The Awards Committee is now accepting nominations for the 2006 THERMOFORMER OF THE YEAR. Please help us by identifying worthy candidates. This prestigious honor will be awarded to a member of our industry that has made a significant contribution to the Thermoforming Industry in a Technical, Educational, or Management aspect of Thermoforming. Nominees will be evaluated and voted on by the Thermoforming Board of Directors at the Winter 2006 meeting. The deadline for submitting nominations is December 1st, 2005. Please complete the form below and include all biographical information.

Person Nominated: _____ Title: _____

Firm or Institution: _____

Street Address: _____ City, State, Zip: _____

Telephone: _____ Fax: _____ E-mail: _____

Biographical Information:

- Nominee's Experience in the Thermoforming Industry.
- Nominee's Education (include degrees, year granted, name and location of university)
- Prior corporate or academic affiliations (include company and/or institutions, title, and approximate dates of affiliations)
- Professional society affiliations
- Professional honors and awards.
- Publications and patents (please attach list).
- Evaluation of the effect of this individual's achievement on technology and progress of the plastics industry. (To support nomination, attach substantial documentation of these achievements.)
- Other significant accomplishments in the field of plastics.
- Professional achievements in plastics (summarize specific achievements upon which this nomination is based on a separate sheet).

Individual Submitting Nomination: _____ Title: _____

Firm or Institution: _____

Address: _____ City, State, Zip: _____

Phone: _____ Fax: _____ E-mail: _____

Signature: _____ Date: _____

(ALL NOMINATIONS MUST BE SIGNED)

Please submit all nominations to: Hal Gilham,
Productive Plastics, 103 West Park Drive
Mt. Laurel, New Jersey 08045

**THERMOFORMING
DIVISION
BOARD MEETING
SCHEDULE**

**Hilton Milwaukee
City Centre
Milwaukee, Wisconsin**

Wednesday, September 21, 2005

Executive Committee Arrive

Thursday, September 22, 2005

7:30 a.m. - 8:00 a.m. - Breakfast

8:00 a.m. - 5:00 p.m. - Executive Committee Meeting, Presidential Suite 2432

12:00 noon - 1:00 p.m. - Lunch

1:00 p.m. - 2:00 p.m. - James Alongi, Finance Chair, meets with Executive Committee

2:30 p.m. - 4:00 p.m. - Technical Chairs meet with Executive Committee, Room 2432

6:00 p.m. - 8:00 p.m. - Board Reception, Presidential Suite 2432

Friday, September 23, 2005

HILTON HOTEL

7:30 a.m. - 8:00 a.m. - Breakfast, Kilbourn Room

8:00 a.m. - 10:00 a.m. - Materials Committee, Miller Room

8:00 a.m. - 10:00 a.m. - Processing Committee, Walker Room

8:00 a.m. - 10:00 a.m. - Machinery Committee, Oak Room

10:00 a.m. - 12:00 noon - ALL OTHER COMMITTEES, OAK ROOM

12:00 noon - 1:00 p.m. - Lunch, Kilbourn Room

1:00 p.m. - 4:00 p.m. - BOARD OF DIRECTORS' MEETING, REGENCY BALLROOM

5:00 p.m. - Bus departs from Hilton Hotel to Wisconsin Club, Tailgate Party and Brewers Baseball Game

Saturday, September 24, 2005

8:00 a.m. - 12:00 noon - Board Members Assist in Parts Competition Setup

6:15 p.m. - Welcome Reception, Convention Center Hall A, 3rd Floor

These sponsors enable us to publish **THERMOFORMING QUARTERLY**

Ceramic Infrared E-Mitters and Panels

E-Mitter® **METAMORPHING** Color Change™ provides a visible indication of operation

Stocked in a variety of Standard Colors, Sizes and Electrical Ratings



Curved Face
(Four Standard Sizes)



TEMPCO can manufacture custom configured panels to accommodate your process



KTE Series High Intensity Quartz Mini-Tube Infrared E-Mitters



Style C
Ceramic Mounting Heads



Style S
Mounting Studs

**Universal 2000®
Tubular Radiant Heater**



Vitreous Silica Quartz Tube



Complete Your Thermal Loop System with Tempco's family of **TEC**™ Temperature Controllers

Call today for your free copy of our 864 page Catalog of Electric Heaters, Temperature Controls and Sensors



© 2004 All Rights Reserved.

TEMPCO Electric Heater Corporation

607 N. Central Avenue • Wood Dale, IL 60191
(630) 350-2252 • Toll Free (800) 323-6859
Fax (630) 350-0232 • E-mail: info@tempco.com

Product Inventory available for Viewing and Selection @ tempco.com

**Flameless
Catalytic
Infrared
Gas Heaters**

**NOW
BETTER THAN EVER!**

Now providing on-site refurbishing and upgrade services

Higher Surface Temperature
...we guarantee cycle times

Smaller Zones
...get more control

More Affordable
...1-2 year payback period



AMERICAN CATALYTIC TECHNOLOGIES

209 Montowese Street • Branford, Connecticut 06405
Phone 800-648-1698 • Fax 203-483-6693

www.americancatalytic.com

Since 1992

These sponsors enable us to publish

THERMOFORMING QUARTERLY



65 South Waukegan Road
Lake Bluff, IL 60044

Custom Engineered Plastic Parts
Vacuum • Pressure • Twin Sheet
We Deliver Parts Under Pressure!

(847) 604-5100

FAX (847) 604-8030



www.pcmwi.com

Quality Thermoform Molds
Since 1972

Portage Casting & Mold, Inc.
2901 Portage Road, Portage, WI 53901
1-800-356-5337 — Fax 1-608-742-2199

McCONNELL CO., INC.

THERMOFORMING CONSULTANTS

Product Design & Development • Manufacturing Analysis
In-Plant Seminars • Expert Witnesses
Legal Research • Consulting

817-926-8287

Fax: 817-926-8298

3030 Sandage Ave.

E-mail: info@thermoforming.com

Fort Worth, TX 76109

PO Box 11512

76110

Visit our Internet website: <http://www.thermoforming.com>



Productive Plastics, Inc.
Award Winning Thermoforming



103 West Park Drive • Mt. Laurel, NJ 08054
(856) 778-4300 • Fax: (856) 234-3310
<http://www.productiveplastics.com>

**Visit the
SPE
website
at
www.4spe.org**

These sponsors enable us to publish **THERMOFORMING QUARTERLY**

Rapidly Adjust the Heat of Your Sheet

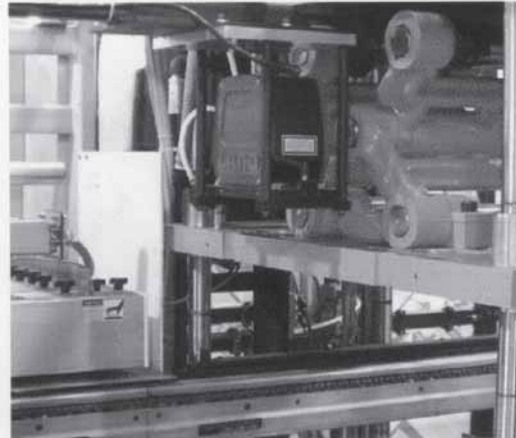

**Affordable, high quality process thermal
imaging for when the heat is on ...**

Landscan Pro LSP6 and LSP7 infrared linescanners produce accurate temperature profiles of thin and thick plastic sheet without contact.

- Powerful and Reliable Software
- Durable Sapphire Window
- 100 Hz Scan Rate
- 1000 Points per Scan Line
- 140F Ambient Without Cooling
- Integral Laser Sighting

LAND

instruments international

An ISO 9001 & 17025 Company

Combustion & Environmental Monitoring
Infrared Temperature Measurement

Land Instruments International

10 Friends Lane

Newtown, PA 18940

Phone: (215) 504-8000

E-Mail: irsales@landinstruments.net

www.landinstruments.net

Premier Material Concepts™

Your needs. Real solutions.

Premier Material Concepts™ is a custom extruder of sheet and roll stock for the thermoforming industry. We specialize in:

- Impact & Modified Acrylic • ABS • TPE • PP • HIPS • PE • Specialty Compounds

Please contact **Premier Material Concepts™**
with your custom plastic and extrusion needs today!

1-877-BUY-PMC6 • www.buypmc.com • eric.hausserman@buypmc.com
(289-7626)

Premier Material Concepts™ is a Rowmark® Company

Enhanced TPO Thermoforming Using High Melt Strength Polyolefin Elastomers¹

BY K.L. WALTON, M.K. LAUGHNER, LAWRENCE J. EFFLER, E.S. GISLER,
DUPONT DOW ELASTOMERS LLC, GENEVA, SWITZERLAND

Abstract

Hard TPOs have grown rapidly in the automotive industry because of their favorable cost/performance characteristics and injection molding processability. Other plastics processes are now either currently used or under investigation. Processes such as blow molding and thermoforming offer the potential to manufacture large parts with much lower tooling costs than injection molding. However, it is well known that conventional polypropylene exhibits poor melt strength. This deficiency has limited its use in either large part extrusion blow molding or thermoforming.

Recently, polypropylene producers have introduced high melt strength polypropylene into the market. These polypropylenes have much higher melt strengths than conventional materials. They are being promoted for used in hard thermoplastic olefin (TPO) applications requiring high melt strengths.

However, other components, particularly the impact modifiers, can now play important roles in the thermoforming characteristics of hard TPO compounds. In a series of experiments, significant changes in TPO Rheology were observed, depending on the level and type of impact modifier used. The characteristics of ethylene/ α olefin copolymer impact modifiers and their effect on hard TPO thermoforming performance will be discussed.

Introduction

Propylene based compounds continue to successfully replace engineering polymers in automotive exterior and interior applications. The primary driver for this substitution is raw material cost. A

desire for lower conversion cost has led some Tier I suppliers to examine methods of large part manufacturing other than injection molding. For example, it is possible to manufacture similar large parts using either thermoforming or blow molding that were formally reserved for injection molding. The primary advantage of these conversion processes is lower capital, including tooling costs. On the other hand, it is well known that conventional polypropylene exhibits poor melt strength (1). The low melt strength stems from the lack of melt strain hardening. This deficiency has limited its use in blow molding. Thus, conventional polypropylenes have very narrow processing windows for most thermoforming and blow molding applications.

Several approaches were attempted to improve polypropylene (PP) melt strain hardening characteristics. For example, high-pressure LDPE was blended with PP at 15-20% (wt) to yield a PP composition with some extrusion coating capability (2). The LDPE has long chain branching (LCB), which causes the polymer to exhibit melt strain hardening, an important attribute in several processes. The LDPE has some compatibility with the PP and thus has an influence on the melt behavior. This blend approach has also been extended to thermoforming applications.

PP manufacturers are now offering alternatives to conventional technology by providing products with LCB incorporated into the polymer backbone. The LCB structure causes the polymer to exhibit melt strain hardening, an important attribute for thermoforming. Numerous methods have been described to incorporate LCBs into PPs (1, 3-5).

Constrained geometry catalyst (CGC) technology utilizes a proprietary catalyst and solution process based on transition metal chemistry, with titanium being the most commonly used transition metal. This catalyst technology enables the copolymeriza-

¹ This paper, presented at 2005 SPE ANTEC, Boston, has been edited for publication in TFG. Any errors or omissions are solely the responsibility of the technical editor.

tion of ethylene with different potential alpha olefin comonomers. For example, DuPont Dow Elastomer's newest plant manufactures both ethylene/1-octene and ethylene/1-butene copolymers using this catalyst. These copolymers are widely used as PP impact modifiers because of their elastomeric nature, compatibility with PP, and pellet form.

The combination of CGC catalyst and the solution process allows the development of reactor conditions, which can be tuned to produce ethylene copolymers containing LCB 96). By judicious reactor control, ethylene alpha olefins (EAOs) with differing levels of LCB are produced (7).

This paper investigates the use of EAOs having high and medium LCB levels in PP as impact modifiers. The effects of these impact modifiers on PP thermoforming characteristics are highlighted.

Experimental

Sample Preparation

The three EAO samples in this study were produced in DuPont Dow's commercial facilities using CGC technologies. Three commercially available PPs were examined. Selected properties are shown in Table 1.

Blend compositions were melt compounded using a Coperion ZSK25 corotating twin screw extruder. The compounded pellets were extruded on

a 50 mm Killion extruder equipped with a 610 mm wide EDI sheet die feeding a 600 mm wide Davis Standard three-roll stack having chromed polished rolls. The die gap was adjusted to yield a 1.1 mm thick sheet. Roll speed was adjusted to minimize orientation. Tables II - IV (see page 12) show the compounded samples tested.

Thermoforming

The sheets were tested for thermoformability using a Lamco thermoformer equipped with 12 individually controlled quartz heaters, top and bottom. An infrared pyrometer was positioned at the bottom of the oven to monitor sheet surface temperature. The average power setting was 40% for the top and 55% for the bottom. Square sheets 56 cm x 56 cm were cut and clamped. After reaching the desired temperature as measured by the oven pyrometer, the sheet was indexed out of the oven, surface temperature was measured via a hand-held pyrometer, and the sheet was vacuum formed into a 14.5 cm x 14.5 cm cavity mold with 2.4 cm depth. The sheets were thermoformed over a temperature range. The temperature at which complete part thermoforming was achieved in the inside cavity was called the "minimum temperature." The temperature at which the sheet formed a hole during vacuum forming was called the "maximum temperature."

(continued on next page)

Table I
Polymers Tested

Grade	Type	Comonomer	Melt Viscosity dg/min	Melting Temp. (° C)	Density (kg/m ³)
PP1	PP high LCB	impact Copolym.	1.8 ^a	163	903
PP2	Clarified PP homopolym.	none	0.42 ^a	164	905
PP3	PP homopolym.	none	1.35 ^a	165	905
EB1	EAO hi LCB	butene	0.25 ^b	93	901
EB2	EAO med LCB	butene	0.28 ^b	48	870
EO1	EAO med LCB	octane	1.6 ^b	93	897
ABS1	Extrusion grade	terpolym.	1.2 ^c	N/A	1040

a = melt flow rate at 230°C, 2.16 kg. wt.

b = melt index at 190°C, 2.16 kg. wt.

c = melt index at 230°C, 10 kg. wt.

N/A = not applicable. ABS has no crystalline melting point

Table II
Simple Two-Component Blends

Compound	PP1	PP2	EB1	EB2	EO1
1	100	0	0	0	0
2	0	100	0	0	0
3	90	0	10	0	0
4	90	0	0	10	0
5	90	0	0	0	10
6	0	90	10	0	0
7	0	90	0	10	0

Table III
Three-Component TPO Composition, [wt. %]

PP3	PP1	EB1
50	50	0
85	0	15
0	70	30
0	100	0
0	85	15
70	0	30
35	35	30
100	0	0

Table IV
Fully-Formulated TPOs

Compound Ingredient	A wt. %	B wt. %
PP3	48	44
PP1	8	12
EB1	24	24
Talc	20	20
Antioxidant	0.2	0.2

For selected samples, the thermoforming sheet sag was measured as a function of index temperature. A video capture technique was used to obtain the data.

Physical Properties

Sheet hardness was measured according to ASTM D2240. The tensile properties were determined according to ASTM D638. Instrumented dart impact was measured according to ASTM D3763. Sheet tear strength was measured according to ASTM D1004.

Rheological Measurements

Dynamic shear tests were conducted at 190, 210, and 230°C on a Rheometrics dynamic spectrometer

model ARES, with a parallel plate fixture of 25 mm and 2 mm cap setting. A 15% strain level was used on all samples.

Results and Discussion

Rheological Characteristics

Figure 1 compares the tan deltas of the three PPs. The relatively flat response of the tan delta curve to frequency in Figure 1 infers that LCB is present in PP1. As seen in Figure 2, the relative flatness of the tan delta curve for EB1 infers a significantly higher LCB level than either EB2 or EO1.

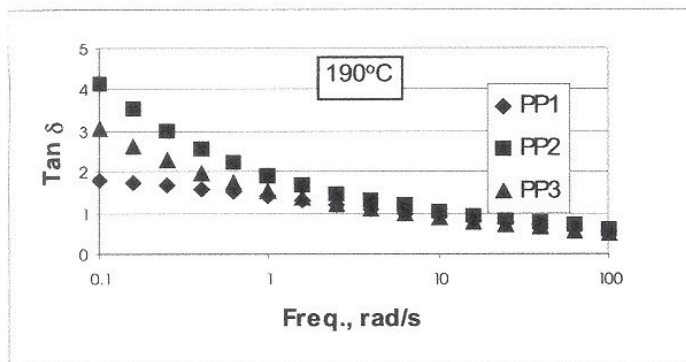

Figure 1. Tan deltas versus frequency of the tested PPs.

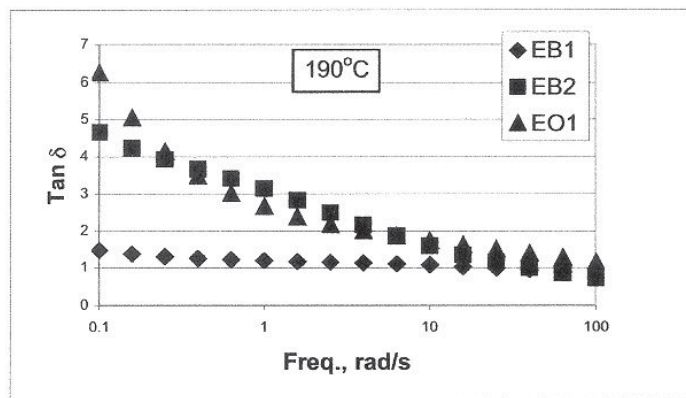

Figure 2. Tan deltas of the tested elastomers in the melt state.

Thermoforming Comparison

Simple Two Component Blends: Figure 3 compares the thermoforming window of PP2 alone and blended at 10% (wt) with EB1, EB2, and EO1. As seen, PP2 (unbranched homopolymer PP) exhibits a very narrow thermoforming window. All of the EAOs improve the PP2's thermoforming window. The widest thermoforming window is observed with compound #3 containing 10% EB1. The sheet of compound #4 exhibits localized thin spots during thermoforming. It is apparent that the incorporation of an EAO with high LCB levels significantly

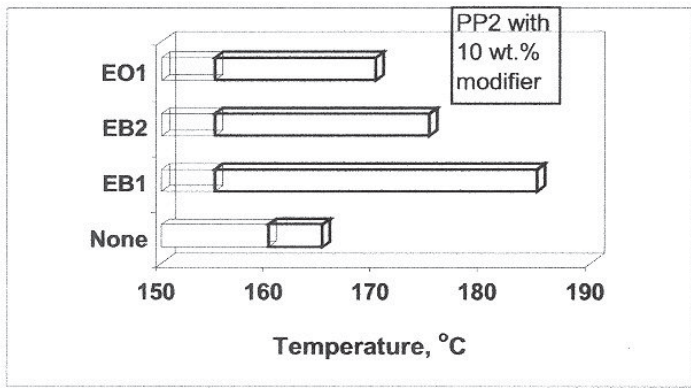

Figure 3. Effect of impact modifier on PP2 thermoforming window.

improves the thermoforming window of standard PP homopolymers by 25°C.

Figure 4 compares the thermoforming window of PP1 alone and blended at 10% (wt) EB1 and EB2.

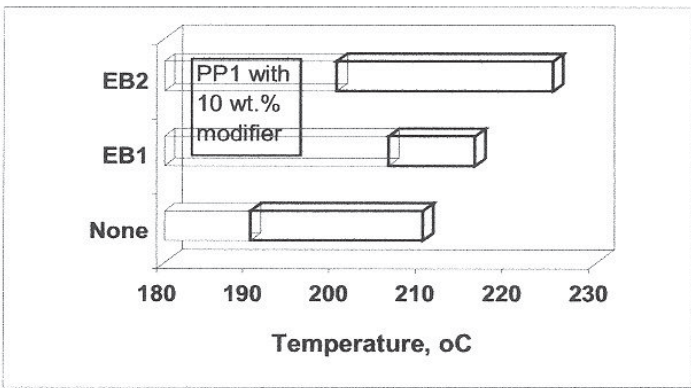

Figure 4. Effect of impact modifier on PP1 thermoforming window.

Note that a much higher temperature is required to thermoform the PP1-based compounds. Sheets based on PP1 exhibit very little sag, indicating significantly higher melt strength than PP2-based sheets. However, little change in the breadth of the thermoforming window is observed. Further, at elevated temperature, hole formation readily occurs. Also, during thermoforming, high levels of sheet “nerve” are observed. No thermoforming benefit is observed by adding EB1 to PP1. However, by adding EB2 to PP1, the thermoforming window increased by 30°C. With EB2 present, the sheet deformed more readily at higher temperatures with no rupture. Perhaps the addition of a lower LCB EAO with reduced melt elasticity improves the melt extensibility of a composition having a branched PP.

Simple Three-Component Blends: It has been previously reported that blends of branched PP with standard PP homopolymers and a branched impact modifier yielded compositions with optimum performance for thermoforming (8). A Three-component mixture design was formulated to determine

the effect of standard PP, branched PP, and branched EB blends on thermoforming sheet sag. The experimental compositions are shown in Table III. ABS1 was used for benchmark comparison. Figure 5 compares the sheet sag versus temperature of selected compounds from this study. A wide range of sheet sag characteristics is seen for these compounds.

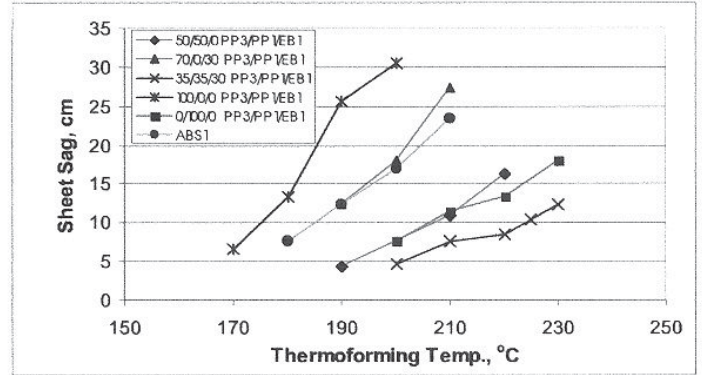

Figure 5. Three-component TPO thermoforming sage range.

As expected, standard PP3 alone sagged most. On the other hand, pure PP3 exhibited low sag. The lowest sag observed was with blends of PP1, PP3, and EB1. The ABS1 sag characteristic is shown in the the middle of the sag curves.

Fully Formulated TPOs: Based on the three component results, two optimize TPO compounds were evaluated and compared with ABS1. Table IV describes these two TPO compounds. Figure 6 shows the temperature-dependent sag characteristics of these two compound. As seen, The sag characteristics of both compounds match the ABS1 sheet sag characteristics reasonably well, with the TPO B compound having the better match of the two. The sag characteristics and sag time of TPO B closely matches that of ABS1 at 210°C.

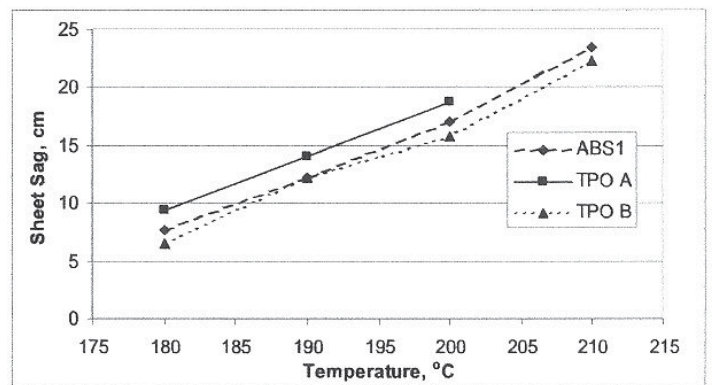

Figure 6. Thermoforming sag comparison, TPO-A, TPO-B, and ABS1.

(continued on next page)

Physical Properties

Figures 7 and 8 are radar plots comparing the effects of adding 10% (wt) impact modifier on the physical properties of PP. As shown in Figure 7, all impact modifiers improve the impact strength of PP1 at 0°C.

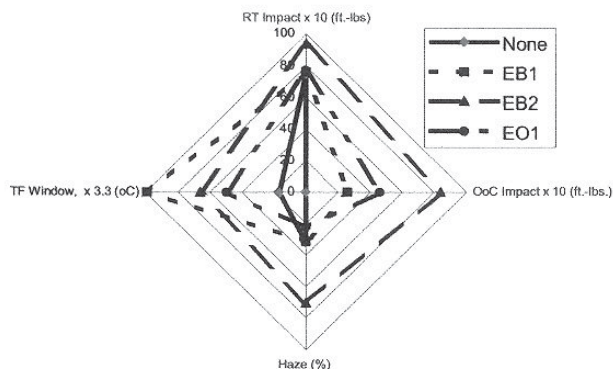

Figure 7. Radar plot of PP2 properties with and without 10% (wt.) impact modifier.

However, the low crystallinity EB2 is a more efficient impact modifier. Because the refractive index of EB1 and EO1 matches that of PP2, sheets are quite clear. As a result of the comonomer content, the crystal structures of these two EAOs match the refractive index of PP. On the other hand, the refractive index of low crystallinity EB2 does not match those of other EAOs. As a result, sheet based on EB2 is hazier. High clarity impact-modified thermoformable TPOs may prove useful in translucent applications or in parts where color depth is important.

Figure 8 compares the effect of adding impact modifier to PP1. The DSC melting point indicates that the product is not a random copolymer. On the other hand, the 0°C impact value of PP1 is higher than that for a standard homopolymers. This suggests that it contains an impact modifier. Additional modifier has little effect on its impact strength. It is evident that PP2 is not designed for transparent applications. The haze of PP2 alone is quite high. It is likely that the haze is partially the result of a low crystallinity im-

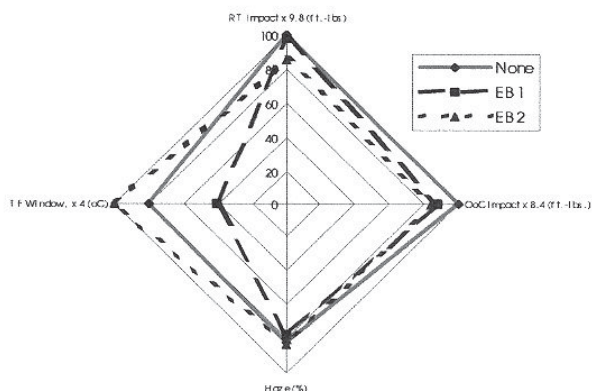

Figure 8. Radar plot of PP1 properties with and without 10% (wt.) impact modifier.

part modifier compounded into the PP during its manufacture. Additional impact modifier had little effect on haze.

Conclusions

The thermoforming characteristics of standard PPs can be significantly improved with the addition of newly developed LCB impact modifiers. Higher crystalline impact modifiers match the refractive index of PP and yield compositions with good clarity. Lower crystalline impact modifiers yield optimum impact modifications.

The branched PP examined in this study exhibited a high level of melt strength, but low melt extensibility. The addition of an impact modifier with low levels of LCB improved the melt extensibility and thermoforming window of this PP.

TPOs containing optimized levels of standard PP, branched PP, and branched EAO yield thermoforming sag characteristics similar to a thermoforming grade ABS.

Acknowledgments

The authors thank Doug Waszneciak for his help in manufacturing the sheets and thank the testing lab personnel of DuPont Dow Elastomers for providing physical property data on the various polymers and formulated compounds.

References

1. Tau, L., et al, US Patent 6,593,005, assigned to The Dow Chemical Company, July 2003.
2. Beren, J.R., Phillips, E.M., Reginister, L., and Tavernier, M., "Polyolefins for Extrusion Coating: Trends and Limitations," Presented at TPPI, Dusseldorf, 1995.
3. Weng, W., Hu, W., and Dekmezian, A.H., "Structure and Property of Long Chain Branched Isotactic Polypropylene," Presented at 226th ACS National Meeting, New York, 2003.
4. Oliver, D., Michel, J., Dupire, J., European Patent Application EP 2002-77723, assigned to Atofina Research SA, 2002.
5. DeMaio, V., and Dong, D., "The Effect of Chain on Melt Strength of Polypropylene and Polyethylene," presented at SPE ANTEC, Toronto, 1997.
6. Laughner, M., Parikh, D., and Walton, K., "New Developments in Metallocene Ethylene Elastomers for Automotive Applications," presented at the SPE Global Polyolefins Conference, Houston, 2001.
7. Lai, S., et al., US Patent 5,272,236, assigned to The Dow Chemical Company, 1993.2
8. DeMaio, V.V., Dong, D., and Gupta, A., "Using Branched Polypropylene as a Melt Strength Modifier - Improvement in Sheet Sag Resistance," presented at SPE ANTEC, Orlando, 2000. ■

Collaborative and Methodical Product Development Reduces Time From Concept to Production

BY ERIC HAUSSERMAN, PREMIER MATERIAL CONCEPTS, FINDLAY, OHIO

The most effective product development initiative ensures that all parties involved have input ... from the resin supplier, all the way through to the end-user since so many factors must be taken into consideration when deciding on a material or a finish.

First and foremost the function of the finished product must be taken into account. How is the product going to be installed? What elements is the product going to face? What is the expectation as far as life of the product? These could include: UV stability, chemical resistance, co-efficient of friction, fire rating, etc. For example, PMC developed a Thermo Plastic Elastomer (TPE) insert for a household step stool. The design of this product covered many of the factors mentioned above. A product was created that achieved a high co-efficient of friction, so that the user would not slip off the stool when in use. It also was chemical resistant, as step stools are often used around cleaning supplies. If not the insert could become easily and quickly degraded.

Next we took into consideration the processes that the material would go through as it was manufactured into a finished product. What kind of temperature is the product going to see in secondary processes? Is any pressure going to be applied to the sheet in secondary processes? Could the material be scratched as it goes through secondary processes? These include: Thermoforming, die cutting, lamination, injection molding, etc.

Consideration of these factors above was critical for this project. First we discovered that the material would go through a secondary die cutting operation. So the material designed had a very clean trim permitting it to be die cut very efficiently. Next the insert was to be placed inside an injection mold. The material we developed withstood a very high temperature, did not "bleed," and maintained a very crisp, clean edge, when the molten plastic was shot behind it.

Creating this product was a very collaborative effort. There was involvement from the resin supplier, the sheet extruder, the die-cutter, the manufacturer of the footstool, and of course feedback from potential end-users. The product was developed, qualified, put through all of the specified testing, and we were able to go from concept to production in 45 days.

We also believe using a "Stage Gate" approach enhanced our success. It made sure everyone knew the objectives, whether we have met our objectives, and that the proper resources were being allocated.

The following steps are an example of an effective Stage Gate process:

- 1. Investigation/quote phase**
 - a. Product criteria
 - b. Product design
 - c. Manufacturing process(s) design
 - d. Quotation
- 2. Sample/Prototype phase**
 - a. List requirements
 - b. Sample run
 - c. Testing
 - d. Submission
 - e. Customer feedback
- 3. Approved product/proceed to production**
 - a. Forecast
 - b. Finalization of manufacturing processes/equipment
 - c. Vendor releases
 - d. Quality plan
- 4. Post Production analysis**
 - a. Continuous improvement opportunities
 - b. Other product/market applications

Product development, and determining the right finish for your thermoplastic product, is a very complex process. If the proper steps are not followed, this can be a very expensive and inefficient process. If you involve everyone, follow the right steps, you can "get the right finish" for your thermoplastic materials and reduce the number of days necessary for the development of your product.

Premier Material Concepts (PMC), is a custom manufacturer of TPE, ABS, HIPS, PP and acrylics for thermoforming, POP display material, converters and custom fabricators. PMC, a division of Rowmark, Inc., serves diverse industries including marine, industrial, aerospace, government, agriculture, automotive, displays, signage, electrical and furniture. For additional information about Premier Material Concepts (PMC) visit their Worldwide Web at www.buypmc.com.

Proper Colleting and Collet Maintenance in CNC Routing of Plastic^{1,2}

BY VAN NISER, ONSRUD CUTTER, LIBERTYVILLE, ILLINOIS

Introduction

Rigidity is a key factor in the routing of plastic material. The problems associated with rigidity involve the part as well as the machine. Parts must be held solidly with established fixturing techniques, and the machine must be appropriately maintained to insure the cutting tool is following the proper tool path in a rigid and concentric fashion. One of the elements that aids in this whole process lies in the area of proper colleting of the router bit and the ongoing maintenance procedure associated with router collets.

Types of Collets

The half-grip and full-grip collets are the two basic types found in CNC routers. Half-grip collets are identified by slits running from the bottom or mouth of the collet toward the top for about 80% of the collet length. These collets are often counter-bored at the top, so that the shank of the tool does not contact the entire length of the collet. The force holding the collet is primarily generated at the mouth of the collet, and proves ideal in situations where the shanks of the router tools are not long enough to fill the entire collet, Figure 1.

The full-grip collet is identified by slits running from both ends of the collet, which creates specific collet sections. Full-grip type collets allow for squeezing pressure to be exerted over the entire length of the collet, Figure 2.

¹This article appeared in *Plastic Distributor & Fabricator*, Nov/Dec 2004, and is reprinted with permission of David Whelan, Editor/Publisher. For subscription information, please contact www.plasticmag.com. The article has been edited by TFQ Technical Editor, who is responsible for any alteration in content or intent.

² Although the article addresses plastic trimming issues, the information is directly applicable to pattern makers and craftsmen working in other materials such as wood.

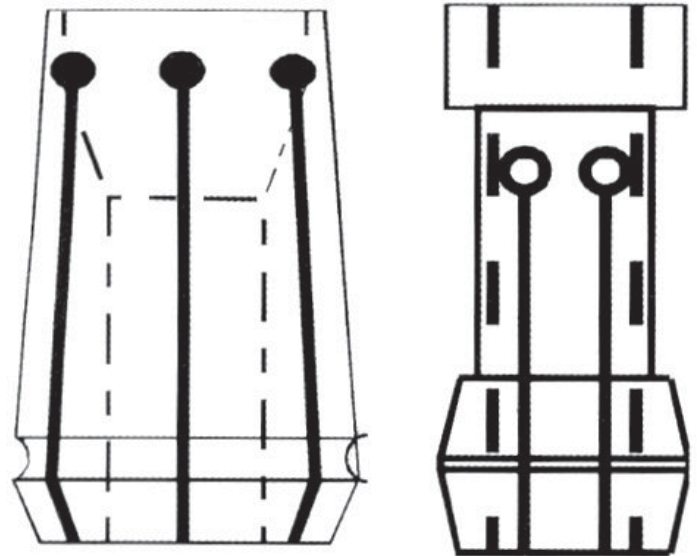

Figure 1. Half-Grip Collets.

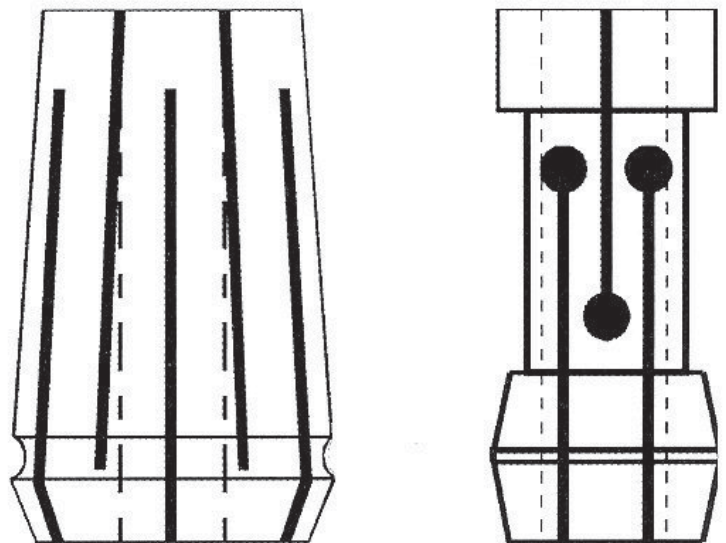

Figure 2. Full-Grip Collets.

Proper Colleting

The proper method of colleting a router bit in the full grip collet is to fill at least 80% of the depth of the collet. This allows the tool to be equally distributed on all sections of the collet and provides an environment where the tool runs in a true circle

or concentricity. Without concentricity, the finish of the plastic will be adversely affected and tool failure can occur. There are situations where the 80% rule cannot be maintained because of inadequate shank length or extreme reach problems. Consequently, it becomes necessary to fill the void in the top of the collet with a filler or collet life plug. This is a practical solution to avoid collapsing of the collet, which may result from not following the 80% rule, Figure 3.

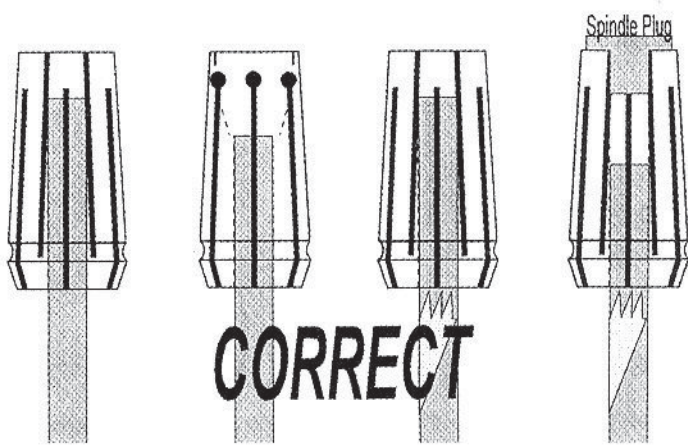

Figure 3. Proper Tool Colletting.

In all router bits, there is an area known as the flute fadeout section of the tool. This is formed when the grinding wheel utilized in the manufacturing of the tool exits the work piece. In order to properly collet a router bit, the mouth or bottom of the collet must contact the router bit slightly above the flute fadeout. Over-colletting or allowing the flute fadeout portion to extend inside the collet can damage the collet. This is a common cause of tool breakage, Figure 4.

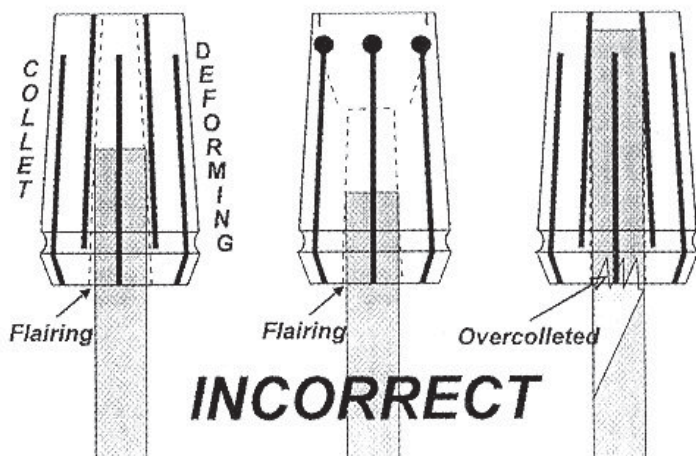

Figure 4. Incorrect Tool Colletting.

Collet Maintenance

Router bits and collets are expected to operate accurately in a work environment inundated with heat and grime. Plastic chips formed by the cutting action of the router bit carry with them resins that migrate through the slits of the collets and adhere to the inside of this closely toleranced mechanism. The resin build-up usually concentrates nearest the mouth of the collet. At this point, the tool is no longer being equally gripped, causing a loss in concentricity and tool run-out. Once again, the lack of a router tool running in a true circle affects the finish of the part and may cause the ultimate demise of the tool, Figure 5.

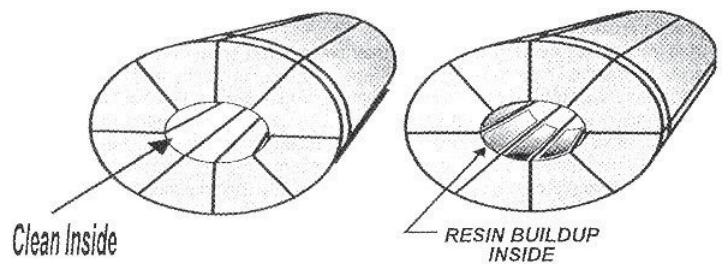

Figure 5. Collet Examples.

Fortunately this problem is easily resolved by cleaning the collets after every tool change. The procedure involves the use of a non-abrasive brass tube brush applied inside the collet in combination with a cleaner such as Rust Free™. All surfaces inside and outside the collet, inside the spindle taper, and matching and mating surfaces of quick-change tool holders, should be thoroughly cleaned and dried before being reassembled. Also the collet nut should be cleaned of resin and chip build-up and regularly replaced to ensure the integrity of the whole collet system, Figure 6.

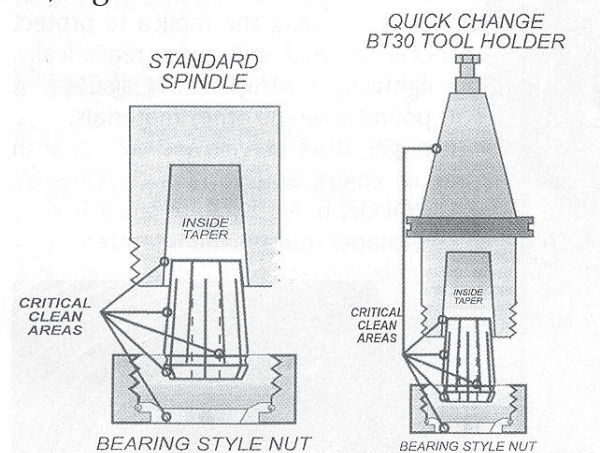

Figure 6. Full-Grip Collets.

(continued on next page)

Collet Replacement

Collets are manufactured from spring steel and regular usage causes a loss of elasticity. Therefore, it becomes necessary to replace collets on a regular interval as part of an ongoing maintenance program. With diligent attention to proper collet maintenance, the average collet should be replaced about every 400-600 hours. Avoiding regular replacement can lead to brittle collets, which may crack or break, and cause permanent damage to the spindle. Re-

placement of collets is a much more economical alternative than replacing router bits or expensive spindles.

Rigidity and concentricity are the key elements in any routing application. The simple process of properly colletting router tools, maintaining collets, and replacing them at regular intervals will safeguard the productivity of the operation and ensure that the finish of plastic parts is not jeopardized.

For more information on this or other cutter issues, contact Onsrud Cutter, 800 Liberty Drive, Libertyville IL 60048, email: vniser@onsrud.com. ■

Tsunami Relief – Thermoforming Style!

On December 26, 2004 at approximately 8:00 am a magnitude 9.3 earthquake devastated the ocean floor off the coast of Northwest Sumatra. The resulting Tsunami traveled thousands of miles across the Indian Ocean, taking the lives of nearly 300,000 people in countries as far apart as Indonesia, the Maldives, Sri Lanka and Somalia.

Early in 2005, the Thermoforming Division started to investigate a way we could help out. Our thoughts were to find a truly unique way to make a difference. We looked into some of the more conventional disaster relief funds, Unicef, Red Cross and Worldvision. That is when I received a phone call from my sister, Barbara McConachie, a registered nurse who has made numerous relief trips to 3rd world countries. Her group, PRN International, was looking to send a small group of doctors and nurses over to Sri Lanka to assist with the relief efforts. This group was experienced in the most efficient way to get in and get busy.

At our winter Board of Directors meeting in Florida, I submitted a request for a donation to PRN International. The request was unanimously approved. On January 28th, 3 doctors and 5 nurses from Bridgeport Hospital left New York for Sri Lanka. Twenty-eight pieces of luggage filled with donated antibiotics, vaccines, analgesics, skin ointments and baby formula made the trip as well. Our volunteers worked their way up the northern coast of Sri Lanka (Ampara) and partnered up with healthcare providers from around the world.

During their stay the PRN relief team treated over 200 people in 3 different refugee camps on a daily basis; revisiting these same people every other day trying to prevent a outbreak of Malaria and Cholera. The physical injuries treated were pneumonia, diarrhea, fevers, open wounds and cellulitis. The physiological wounds were just as bad if not worse; most of the people lost 3 out of 4 family members. Depression and Post Traumatic Stress Syndrome is

rampant. The widespread devastation witnessed by these workers cannot be put into words. PRN International and my sister would like to thank the Thermoforming Division for their \$2,500 donation. The Thermoforming Division would like to thank the volunteers at PRN International for actually doing what most of us just talk about. We would like to think that in some tiny way, though PRN International, D25 made a difference, Thermoforming Style.

~ By Mike Sirotnak, Solar Products ■



History of Thermoforming – Part I

BY STANLEY R. ROSEN, PLASTIMACH CORPORATION, LAS VEGAS, NEVADA

Thermoforming Pioneers 1930-1950

The development of modern machinery for the thermoforming industry took place on the shoulders of very perceptive pioneers during the years 1930-1950. These experimenters did not have the modern tools or hindsight we now possess yet they developed many of the processes we currently employ. Information contained in this article was abstracted from periodicals, patents, and conversations with industry innovators. Some firms during this period developed proprietary equipment to thermoform their products and they are nameless at this time.

A great deal of development effort pre-World War II went into forming airplane acrylic canopies free of flaws. E. L. Helwig of Rohm and Haas Company in Philadelphia, an acrylic resin manufacturer, has two patents using different techniques which when modified can be used today.

Figure 1. Helwig's patent, filed on 11-27-1938, illustrates the forming of a canopy from a pre-heated sheet of acrylic forming which utilizes a hot fluid under variable pressure. The mold was water cooled so that sheet surface facing the cavity would chill and be hard enough to avoid being marred against the mold surface. The inner surface sheet would be free of blemishes since its contact is with the hot fluid. This process is similar to a modified method used today where air pressure forms sheet against a temperature-controlled mold producing high quality parts.

Ed. Note I: The philosopher Santayana said, "Those who cannot remember the past are destined to repeat it." Stan Rosen is undertaking a prodigious project – identifying the pioneers who laid the foundations of the industry we know so well. Although shaping of sheet extends back to pre-history – oil-heated and shaped tortoise shell and steam-heated and shaped wood, Stan begins the journey in the 1930s. We hope you enjoy the trip!

Ed. Note II: Each year since 1982, the SPE Thermoforming Division has honored a leader in the thermoforming field. Bow Stratton was the 1983 Thermoformer of the Year. Bob Butzko was the 1985 Thermoformer of the Year. And Stan Rosen, the author of this article was the 1991 Thermoformer of the Year. Stan can be reached at thermoipp@earthlink.net.

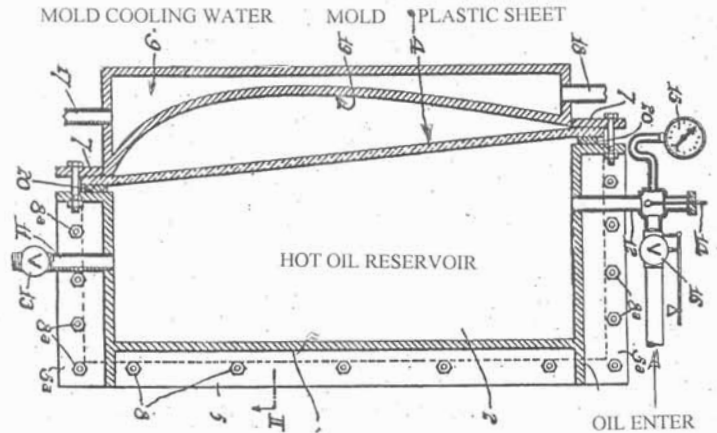

Figure 1. H. E. Helwig of Rohm and Haas Corp. filed for a patent 11-27-1936 using hot oil pressure for forming acrylic.

Figure 2. Helwig patent filed, on 8-28-1942, describes a male snap-back technique using an oven-heated acrylic sheet which is clamped to the device with quick-acting clamps or bolts. Figures 2-1 and 2-2 exhibit the use of vacuum to pre-stretch the hot sheet and allowing atmospheric pressure to force the cooling plastic to the male cavity. Figures 2-3 and 2-4 show air pressure creating a bubble of hot plastic which, after the air is exhausted from the

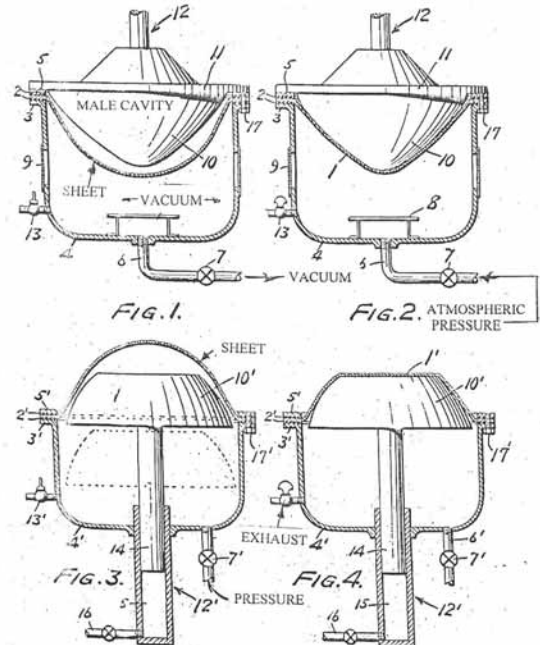

Figure 2. H. E. Helwig filed for a patent 8-28-1942 using snapback forming.

(continued on next page)

(continued from previous page)

chamber, the cooling sheet then conforms to the cavity. The expansion of the surface of the hot sheet before forming is used to assist in producing uniform wall thickness on the finished part. This process appears to be the first patent in which a male cavity is used in thermoforming.

Figure 3. R. E. Leary of Dupont Corp., patent filed 12-27-1940, illustrates vacuum forming using two methods of controlling a radiant heat source to achieve a uniform wall thickness.

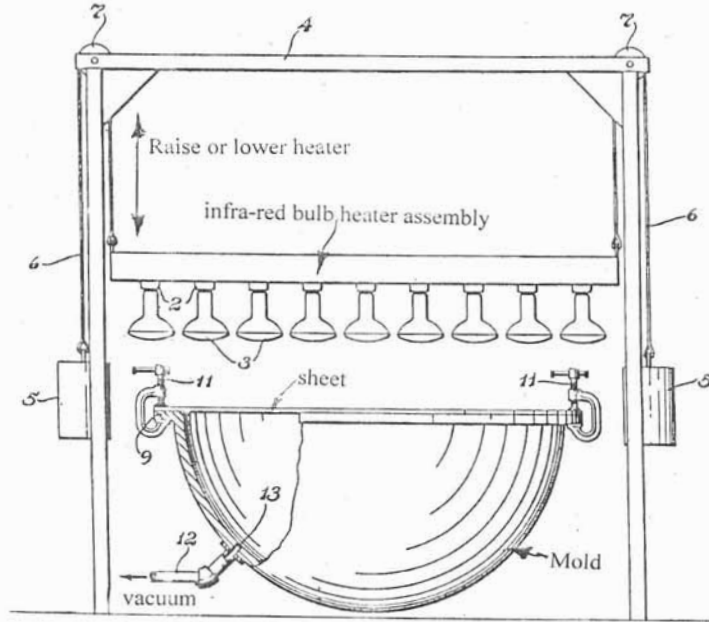

Figure 3. R. E. Leary of DuPont Corp. filed for a patent 12-27-1940 for a vacuum forming apparatus.

1. This heater assembly can be raised or lowered relative to the plastic sheet line. Moving a heat source away from or toward the sheet is a powerful method of heat control. The distance of a radiant source to its receptor is not a linear function and a small movement can create big differences in temperature distribution across a sheet surface.

2. Each lamp in the heater assembly is individually controlled so that the heating pattern can be zoned to promote a uniform temperature distribution across the sheet. This patent suggests the use of radiant heating at the forming site rather than preheating the sheets in an oven and later transporting them to a mold.

Figure 4. J. J. Braund, patent filed on 2-17-1936, is not a plastics fabricating patent but it has an interesting concept. Braund in the early 1930s started to develop a process to produce inexpensive three-

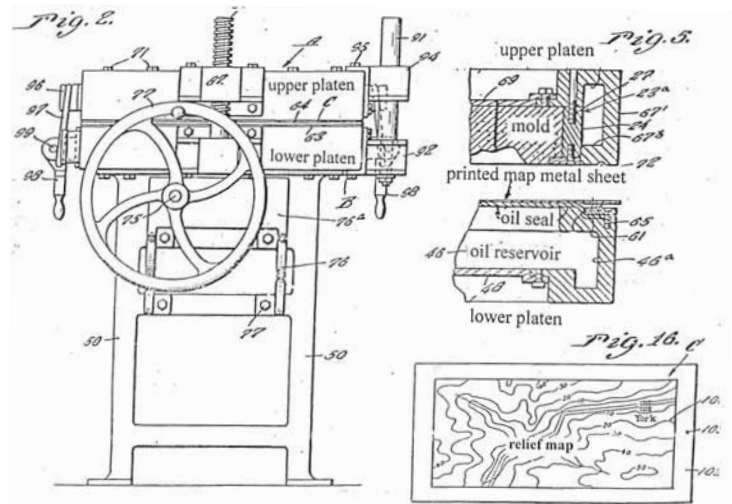

Figure 4. J. J. Braund filed for a patent 2-17-1936 for a relief map duplicating machine.

dimensional relief maps for the U.S. Coast and Geological Survey. A relief map sheet is distortion printed with each color referring to a specific elevation. When formed, the map might use green for sea level at the sheet line and white for the tips of the mountains in the deepest part of the mold. This technique locates a pre-printed sheet of ductile metal facing a female mold mounted above the blank. The back face of the sheet is sealed to a shallow box and the whole assembly is locked in a powerful clamp frame. Hydraulic oil under pressure is

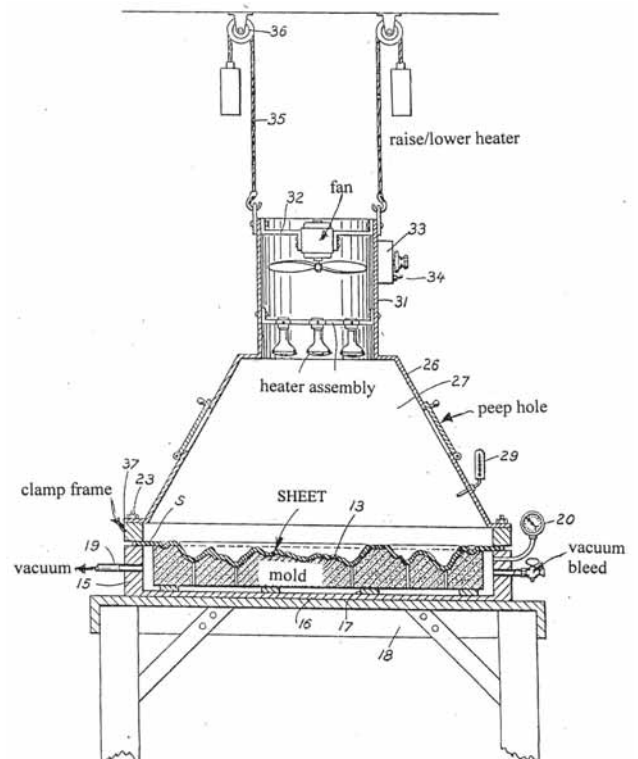

Figure 5. J. T. Braund filed for a patent 9-24-1946 for a relief mat vacuum former using convection heat.

pumped into the box, forcing the metal sheet to flow into the mold. If the date of the above patent was 1946 instead of 1936, Braund could have chosen to substitute a plastic sheet instead of metal and might have used air instead of oil pressure.

Figure 5. J. J. Braund filed a patent on 9-24-1946, which describes a system for vacuum forming plastic relief maps similar to his earlier 1936 metal forming methods. This sheet heating system is analogous to R. E. Leary's oven, except the heater provides convection heat transfer rather than radiant heating. The top fan creates an air flow through the

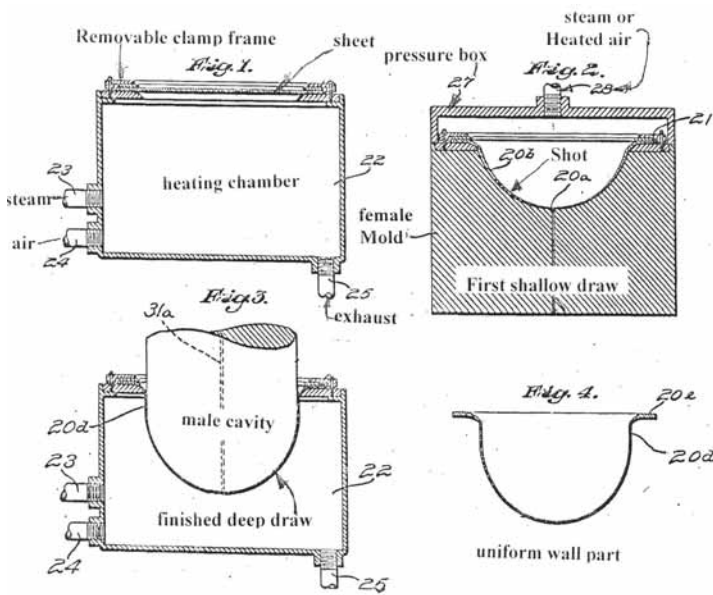

Figure 6. F. E. Wiley of Plax Corp. filed for a patent 6-1-1944 for a method of deep drawing plastic sheets.

bank of heat lamps which increases the air temperature within the hood and heats the plastic to forming temperature. Braund claims this method creates a very uniform sheet temperature for accurate registration of pre-printed sheet to vacuum forming mold.

Figure 6. F. E. Wiley of Plax Corp., Hartford, Connecticut, filed for a patent on 6-1-1944. It is concerned with forming techniques which produce a uniform wall thickness on deep drawn parts. This system is a three-step process in which the sheet is pre-heated, and in the second operation it is drawn to a shallow depth in a female cavity. A third operation draws the sheet to the deeper finished size on the male cavity. The heating medium is steam, which raises the sheet to forming temperature in all the steps and the clamp which holds the pre-

heated sheet frame is moved manually from step to step. Wiley has developed four similar variations of this technique. (Only one is illustrated as follows:)

Figure 6-1 is a steam heating chamber. In Figure 6-2, a shallow female mold and sheet is pressure-formed using steam and its wall thickness is at a minimum at (20a) and thickest at (20b). In Figure 6-3, the sheet is steam-reheated with male cavity (31) lying in the shallow form to prevent distortion. When the sheet reaches forming temperature the steam is exhausted and the cavity (31) is extended to final depth while atmospheric air pressure forces the sheet against the cavity. The male cavity draws material from the upper side wall (20d) and very little from the tip (20a) which results in a fairly uniform product, Figure 6-4. ■

References

- J. H. DuBois, *Plastics History USA*, Cahners Publishing Co., Inc., 1972.
- J. J. Braund, US Patent 2,066,555, filed 2-17-1936.
- E. L. Helwig, US Patent 2,142,445, filed 11-27-1936.
- C. B. Strauch, US Patent 2,229,613, filed 11-22-1938.
- R. E. Leary, US Patent 2,377,946, filed 12-27-1940.
- G. W. Borkland, US Patent 2,347,806, filed 10-2-1941.
- E. L. Helwig, US Patent 2,365,637, filed 8-28-1942.
- F. E. Wiley, US Patent 2,468,697, filed 6-1-1944.
- J. J. Braund, US Patent 2,493,439, filed 9-24-1946.
- G. W. Borkland, US Patent 2,559,705, filed 7-8-1947.
- Phone conversation with Jim Phohl, Plaxall Corp., Long Island City, NY, Dec. 2004.
- Phone conversation with Steve Hasselbach, CMI Plastics Corp., Cranbury, NJ, Dec. 2004.
- SPI (NPE now), archives from Hagley Museum and Library, Wilmington, DE, for exhibitors 1950, 1952.
- Modern Plastics and Modern Plastics Magazine, issues 1950-1953.
- Army Map Service, Relief Map Division, Corps. of Engineers, Washington, DC.

**PART II WILL FOLLOW
IN THE NEXT
THERMOFORMING
QUARTERLY**

Understanding How a Sheet Stretches¹

BY JIM THRONE, SHERWOOD TECHNOLOGIES, INC., DUNEDIN, FL

We began our discussion of part design by reviewing why we might not want to quote on a job. But let's suppose that we did quote on the job. And we got it. Now what?

Forming into a Mold v. Forming onto a Mold

In the not-so-politically-correct jargon of the day, if we form *into* a mold cavity, the mold is called a "female cavity." A better PC² phrase is "negative mold." If we form *onto* a mold, the mold is called a "male mold." The proper PC phrase is "positive mold." Is there a difference in forming "into" v. forming "onto"? Of course. Let's consider for the moment, forming a very simple truncated cone. If we use a mold cavity, the sheet first drapes into the open cavity, then stretches into the cavity with the sheet progressively laying on the mold surface. Keep in mind that the sheet that contacts the mold surface usually doesn't stretch any further. As a result, the sheet that is free of the mold becomes thinner and thinner as it is stretched to the bottom of the mold. The wall of the resulting part is thickest at the rim and thinnest at the bottom. The thinnest region of the part is in the corner where the wall meets the bottom. We can show arithmetically that if

¹ This is the third in a series that focuses on part design.

² PC. Politically correct.

³ We discuss draw ratio in the next lesson.

⁴ By "positive surface," we mean that surface that the customer considers to be the more important one. Usually the surface against the mold is considered the positive surface, but not always.

⁵ Efficacious: Producing or capable of producing a desired effect.



THERMOFORMING 101

the wall makes a 60-degree angle with the horizontal rim, the wall thickness decreases linearly from the rim to the corner. If the wall makes a 90-degree angle [think soup can], the wall thickness decreases exponentially.

Now consider using a truncated cone male mold. The sheet first touches the mold at the bottom of the part being formed. As the mold pushes into the sheet, the sheet stretches between the clamp and the bottom of the mold. If the sheet doesn't touch the sides of the mold until the mold is completely immersed in the sheet, the sheet thickness is usually quite uniform. If the sheet progressively touches the sides of the mold as the mold is being pushed into the sheet, the wall of the resulting part will be thickest at the bottom and thinnest at the rim.

Does it make a difference whether we form into a cavity or over a mold? If part performance is important, probably not, if the part draw ratio³ is very low [think picnic plate or aircraft engine cover]. As the draw ratio increases, however, the thinnest sections of the part begin to control the performance of the part. Several other factors can influence our decision, such as:

- Is it easier to prestretch the sheet when forming into a cavity or over a mold?

- Is it easier to machine a cavity or a male mold?
- Is the rim thickness important, as in the case of thin-gauge containers?
- And does the customer need the inside or the outside of the part to be the positive surface⁴?

Usually – but not always – mechanical plugs are more effective in stretching sheet into a cavity, female molds are easier to fabricate than male molds, and rim thickness is better controlled with female molds. We'll revisit some of these factors later.

Forming "Up" v. Forming "Down"

What does this mean? If the mold is placed above the sheet, the mold is immersed in the sheet and the part is formed up onto or into the tool. If the mold is placed below the sheet, the sheet sags into or onto the mold and the part is formed down onto or into the tool. Why is this an issue? In thin-gauge thermo-forming, forming up has advantages with female molds. Gravity helps when releasing parts from multi-cavity tooling. And the parts are properly oriented for in-line trimming. Having said that, keep in mind that it is easier to mechanically prestretch the sheet into fe-

male cavities if the molds are below the sheet.

Although the mold weight may prevent mounting the mold over the sheet in heavy-gauge forming, there are some advantages here too. For example, when a male mold is mounted over the sheet plane, sheet sag acts to prestretch the sheet prior to the mold immersion. The sheet is formed down for most heavy-gauge forming into female molds. Again, sheet sag acts to prestretch the sheet prior to forming. And certainly, it is easier to activate and maintain mechanical plugs if they reside above the sheet rather than below.

Mating Parts

It should be apparent that the part side against the mold maintains a more accurate dimension than the other side. The mold side is chosen whenever the part is to mate with another dimensioned part. For example, for an integral-lid container to be liquid tight, the outside of one half must mate with the inside of the other. This may require that one half is formed into a female mold while the other is formed on a male tool.

An Observation

When quoting on a job, it is always advisable to keep in mind the capability of your equipment to form the part in the most efficacious⁵ and least costly manner. If you can't form up, don't quote on a job that is best produced in this fashion. The more tortuous the path to perfect parts, the greater the degree of difficulty. And surely the greater the chance for quality issues. ■

Keywords: *positive mold, male mold, negative mold, female mold, draw ratio, forming up, forming down, sag*

These sponsors enable us to publish **THERMOFORMING QUARTERLY**

Aristech Acrylics — **Taking Thermoformed Products to a Higher Level**

Altair Plus® and Quarite Plus® combine the properties of continuous cast acrylic and ABS in one sheet to provide:

- Premium Aesthetics
- Superior Physical Properties
- Unsurpassed Weatherability
- Excellent Chemical Resistance



Quality that comes to the surface.

For more information, call our Commercial Development Department at 1•800•354•9858
www.aristechacrylics.com



IF YOU ARE LOOKING FOR A ROUTER, CALL US...

- 3 & 5 AXIS CNC ROUTERS
- TRIMMING OR MOLD MACHINING
- HIGH ACCURACY AND HIGH SPEED
- ONE PIECE OR HIGH VOLUME
- SERVICE AND SPARE PARTS
- DEMO AND TRAINING CENTER
- SINGLE AND TANDEM TABLE
- 2'x2'x2' TO WHATEVER SIZE YOU NEED

JRM International, Inc.

5701 Industrial Avenue
Rockford, IL 61111
Toll Free: 800-676-4755

Internet: www.jrminternational.com • Email: jrmsales@jrminternational.com

Specializing in Standard Solutions For Unique Problems



Tooling Technology, LLC

A TOOLING TECH GROUP COMPANY

100 Enterprise Drive • Ft. Loramie, OH 45845

tel: (937) 295-3672 • fax: (937) 295-3677

Website: toolingtechgroup.com

- Vacuum forming (twin sheet, single sheet, pressure form)
- Rotational molding
- Blow molding
- Router Fixtures
- Compression molding
- E.P.S. molding
- Deep Hole Gundrilling
- Rubber molding
- Polyurethane molding
- Carpet stamping dies
- Metal stamping dies
- Vinyl forming
- Pulp molding
- Models & patterns
- Check Fixtures

Full in House Design, CNC Machining, Aluminum Foundry, & Fabrication Services



SOLAR KOTE®

Acrylic Capstock and Film

Capstock solutions for thermoformed sheet.

- Outstanding for ABS, PC/ABS, PVC and HIPS
- Weatherable and easy to fabricate
- Excellent gloss control – from flat matte to ultra high gloss
- Chemical-, scratch- and UV-resistant
- Available in metallic, clear or any color

www.solarkote.com
 Phone: 215.419.7982
 Fax: 215.419.5512
 E-mail: andrew.horvath@altuglasint.com

ALTUGLAS INTERNATIONAL
ARLENIA GROUP

Altuglas® and Solarkote® are registered trademarks belonging to Arlenia.
 © 2005 Arlenia Inc. All rights reserved.

Sales of new and used plastic equipment



Supplying the World with Plastic Processing Equipment

Auctions • Appraisals • Liquidations
New and Used Machinery Sales
Thermoforming • Injection Molding • Extrusion
Blow Molding • Rotational Molding

Why buy with Stopol:

- ◆ If it is out there, we will find it. With our database of more than 27,000 companies, we will locate the equipment you need.
- ◆ Our expertise and knowledge will provide you with the best machines to meet your needs.
- ◆ Our vast inventory provides you with a variety of choices and alternatives.
- ◆ Photos and video footage are available.

Why sell with Stopol:

- ◆ Actively market your equipment to more than 27,000 companies, utilizing phone, fax, email and advertising campaigns to get your equipment in front of qualified buyers.
- ◆ We include your equipment on our web site which produces more than 125,000 hits per month.
- ◆ We team with the most recognized and trusted publications in the plastics industry -- *Plastics News*, *Modern Plastics*, *Plastics Hotline* and *Thermoforming Quarterly* -- to market your equipment.
- ◆ Global presence with offices in London and Shanghai.

Whether its remarketed plastics processing equipment, a plant auction, inventory liquidation, or the sale and acquisition of a business, product line, or manufacturing license – Stopol is the resource.

STOPOL NEWS

Lyle Industries, Inc. has announced the appointment of Stopol, Inc. as exclusive representatives to market the Lyle RFT Custom thermoformer and related equipment in North America. The RFT Custom offers complete form-trim stack capabilities in an economical, rugged package. Standard mold size is 32 x 36 inches. An available quick-change tooling package helps make the RFT Custom a versatile, efficient choice for a variety of applications, and the heavy duty construction helps ensure durability and precise thermoforming performance.



Stopol Office - Europe
 London Berkeley Square
 2nd Floor
 Berkeley Square House
 London, W1J 6BUK
 Phone: +44 (0) 207-887-6102
 Fax: +44 (0) 207-887-6100
 Eu_sales@stopol.com

Stopol Office - Asia
 Shanghai One Corporate Center
 16F One Corporate Avenue
 22 Hu Bin Road
 LuJiao District
 Phone: +86 21 6122 1302
 Fax: +86 21 6122 2418
 Ap_sales@stopol.com

STOPOL, Inc., 31875 Solon Road, Solon, OH 44139 U.S.A.
 Ph: (440) 498-4000 • Fax: (440) 498-4001 • www.stopol.com

G. L. Beall, *The Evolution of Plastics in America (As Seen Through the National Plastics Expositions)*, Plastics Historical Society Occasional Paper No. 1, 1 Carlton House Terrace, London SW1Y 5DB, United Kingdom, 26 pdf pages when printed, sales@plastiquarian.com, ~\$18.00.

It is fitting that Beall's latest effort (1) is on the history of plastics as viewed from the exhibits seen at NPEs and (2) is on a plastic CD-ROM. It is also appropriate that in this issue, we feature the first part of Stan Rosen's review of the history of thermoforming in the Industrial Practice column. The first NPE was sponsored solely by SPI and was held in New York City in 1946. The public was invited to the inaugural Exposition and the public came – 87,000 – an attendance record that was not surpassed until 2000! Of course, after the first NPE, the conferences were ostensibly closed to all but members of the plastics industry.

Even though the public viewed plastics as wondrous things in 1946, it seemed that the industry did not really begin to believe in itself until the late 1970s. Attendance appeared to plateau below 40,000 during the intervening years. The attendance in 1982, for example, was only 41,000. Attendees in those intervening years would have seen the shift from cellulose and phenolics to polyolefins and urethanes, from a dominance of custom molders to the dominance of material suppliers and major machinery builders, from just over a billion pounds of plastic consumed a year to more than 40 billion pounds of the stuff. The attendees would have seen a 42-pound compression molded television cabinet, Monsanto's plastic "House of the Future," the newly-invented screw in-

¹ The reviewer spent many months working on both of these projects, saw them exhibited at NPE, and then watched the first fail FDA trials and the second fail economically.

jection molding machine, the blow-molded plastic milk bottle, the nitrile barrier carbonated beverage bottle, Coors molding-with-rotation (MWR) beer can¹, the Weyerhaeuser 714 composite can¹, pink flamingos, and the following litany of new plastics – LLDPE, rigid PVC, PP, EVA, ABS, mPPO (Noryl), continuous cast acrylic, ionomers, PPS, and PET. And if you were a collector, you would have tried to take home hula hoops, swimming pool noodles, and PP garden chairs, among other attractive give-aways.

This is a fascinating trip down memory lane for many of us. Beall's first show was in 1958 in Chicago; mine was in 1966 in New York City. And I'm sure that both he and I have made the effort to go to every one since. I, like Beall, remember both the excitement of the new ideas and the glitz and glamour of the exhibits. Gone are the days when exhibitors attracted us to their booths with comely lasses in very short skirts, or tickets to local shows (particularly in NYC), or fancy gentlemen's after-hours clubs where libations abounded.

Sometimes in the grim reality of today, we need to reflect on another time – not as intense, not as throat-cutting – when new ideas were not kept as secrets but were touted as representing the genius of our industry, daring the competition to better them.

Take time to seek out this CD-ROM. It's worth the time and effort. And if you weren't around for this era, read it and pretend you were. Five books out of five.



~ Jim Throne

These sponsors enable us to publish

Thermoforming Quarterly

THE FOXMOR GROUP, INC.
Serving the Plastics Industry with Expertise and Integrity.

Roger Fox David A. J. Morgese

(630) 653-2200

www.foxmor.com

These sponsors enable us to publish **Thermoforming Quarterly**



**QUALITY
EXTRUDED
SHEET**
for
Thermoforming

- Acrylic
- Impact Acrylic
- HIPS
- ABS
- Coextrusion

SOLAR-KOTE[®] A
SOLAR-KOTE[®] H
weatherable coextrusion
(for HIPS and ABS)

SOLARKOTE is a registered trademark belonging to Atofina.

Contact us for more information about our custom products:
2121 Old Dunbar Rd., West Columbia, SC 29172
Phone: 803.796.0600 | Fax: 803.791.9620
email: john.temple@bunzlcolumbia.com | www.bunzlcolumbia.com

PROTHERM

Industry-leading process heating capabilities for just about every industry that needs to finish a product!

From simple heater arrays to complete conveyORIZED ovens, **PROTHERM™** completes your project from product analysis, testing, design, to final build.

Whether you're finishing textiles, converting film or foils, thermoforming plastics, or powder coating fenders, you can rely on **PROTHERM™** for complete design, installation and start-up support.

Contact a PROTHERM™ Applications Specialist for assistance at 1-800-793-2077.

For more information...
Visit our web site at **www.pro-therm.com**



Series FSA, 40, and INFRAROUND infrared heaters for OEM and product manufacturing

Web Dryer for textiles & material converting applications

Thermo Plastic Annealing Oven



WECO PRODUCTS

Offering the finest in **INFRARED**
Process Heating Products!

www.wecoproducts.com

Quartz Tungsten

Quartz Halogen

FastIR System

Full Oven Platens

Let us offer expert professional assistance for all your Infrared needs...From Ceramic Elements to Full Oven Systems...**WE CAN HELP** Quartz, Quartz Tungsten, Halogen all from **STOCK!** Fully assembled Reflectors to ease oven construction....Panel Heaters and Full Oven Platens constructed to your Specifications

901 Tacoma Court Clio, Michigan 48420
810-686-7221 fax 810-686-7564



Ceramicx
Ireland Ltd

Council Report ... Atlanta, Georgia



BY STEVE HASSELBACH, COUNCILOR

ANTEC

Registration at ANTEC was 2,658 (including participants in the seminars.) A total of 168 registrants attended 19 Society seminars.

Incoming President Len Czuba's SPE mantra is "Connect, Collaborate, Compete!"

From the Council Floor – Rebates:

The Council discussed the disposition of rebates and accepted the proposal drafted by a special subcommittee chaired by Bill O'Connell. Most changes to the rebates will take effect in 2007 with the one exception that rebates in 2006, while based on the prior system, will be paid quarterly.

The main differences between the old and new systems are as follows:

- Budgeting total rebate dollars – For example, if Council budgets rebates at \$350,000 and the actual calculation comes to \$315,000, every group would receive 111% of their calculated rebate. Likewise if rebates are budgeted at \$350,000 and the actual calculation comes to \$390,000, every group would receive 90% of their rebates. Furthermore, rebates will be paid quarterly in the same year they're budgeted. This provides Council and SPE with a couple of important advantages. First, spreading the rebate payments out helps with cash flow management. Second, paying them as part of a budget in the same year allows Council to make decisions about rebates closer to the time actual rebates will be paid, helping with balancing the budget. In the event there are catastrophic difficulties, Council has the flexibility to reduce the total rebate amount as it also reduces spending in other areas. Likewise, in times of plenty, Council would have the flexibility to distribute more funds to SPE groups.

- Paying rebates quarterly – As mentioned above, this helps tremendously with cash management and will be initiated in 2006 (so rebate payments in 2006 will be based strictly on the old calculation which is based on membership as of 12/31/05, and will be distributed quarterly).

- Making the 3 changes to the calculation – These are some minor "common sense" changes that do not greatly change the individual amounts. The changes are too detailed to present here, but please refer to the proposals sent to you prior to the Council meeting if you want to review them. Again, these changes will not be implemented until 2007.

- Paying rebates only for dues paying members – In the past, folks who paid no dues (unemployed members, distinguished members, etc.) were still included in the rebate calculations. The pool of these folks is small, especially when distributed across all of our groups.

- Dropping the rebate for the seldom-collected initiation fee – SPE's initiation fee is more often dropped as part of a promotional incentive for new members. Since SPE does not collect these funds, the new system will take the small amount that was being distributed to groups out of the calculation. Again, no individual group is going to be materially affected by this change.

- Tiering Division rebates – Under the old system, Division rebates were not tiered the way Section rebates were. This makes the two systems more parallel.

- Having performance criteria for rebates – This is not entirely new. The current system requires a Board of Directors and the submission of the required financial statements. The three items below are new, and the idea here is to monitor how groups are serving members, and give the Sections/Divisions Committees a heads up on any

These sponsors enable us to publish **THERMOFORMING QUARTERLY**

Thermoformers, It's Your Choice

Long-lasting, custom "machine tool quality," heavy duty thermoforming machinery at highly competitive prices from AVT,

OR

Short-lived, "cookie-cutter" thermoforming machines that barely get you by.

Since 1995. Selling quality thermoforming systems worldwide. Manufacturers of the world's largest rotary system. Universal clamp frames, accessories too.

Contact us for a quote. And don't forget to ask us about our universal clamp frames.

3870 West Highway M-61, Gladwin, MI 48624
Tel: 989-246-0445 • Fax: 989-246-0465
Web: www.avtmachines.com
E-mail: sales@adv-ven-tech.com

group that is failing to provide these basic requirements so we can work together to get things on track.

- No rebates for sections and divisions whose council seat has been declared vacant by Council (non-attendance for 3 consecutive Council meetings)
- Requiring communication with members (demonstrate regular communications to members)
- Having a plan (helps to demonstrate that activities are ongoing)

For a full copy of the proposal, go to the SPE Leadership page at: <http://www.4spe.org/communities/leadership/0505/materials.php>.

New Charters

The Council approved the charter of the Flexible Packaging Division. Two new SIG's were presented to Council: Nanotechnology and Micromolding. A student chapter was established at the University of Mississippi.

Awards & Recognitions

In addition to the recognition of the retiring administration, two additional awards were given out. The Michael Cappelletti Excellence Award was given to Bill O'Connell and the James Toner Service Excellence Award was given to Tobi Gebauer.

Outgoing President Karen Winkler thanked her Executive Committee for their hard work. Incoming President Len Czuba introduced his Executive Committee. New Executive Committee Vice-Presidents are: Russell Broome, Héctor Dilán, Lance Neward, and William Smith. Paul Anderson is the 2005-2006 Treasurer and John Szymankiewicz is the 2005-2006 Secretary.

Presentations

Composites Division - \$1,500 Harold Giles Scholarship; \$1,000 Foundation Scholarship program

Mold Making & Mold Design - \$1,000 Student Author Travel Fund

Detroit Section - \$2,000 Essay contest; \$2,500 International Education Award in honor of Fred Schwab

\$5,000 Robert Dailey Scholarship

Color & Appearance Division - \$1,000 Donation to the SPE Foundation

These sponsors enable us to publish **THERMOFORMING QUARTERLY**

GN1406TM Thermoformer





Ideas by the Cupfull!

Ideal for:

- Cup and Lid Production
- Tub Production

Features:

- Compact Design
- Inexpensive Tooling
- High Speed Production



G.N. Plastics Company Limited
 PO Box 710
 345 Commons Road
 Chester, Nova Scotia
 Canada B0J 1J0

Tel 1-902/275 3571
 Fax 1-902/275 3100
 E-Mail gn@gnplastics.com
 Web Site www.gnplastics.com

We Welcome Your Inquiries.

Plastics for the Thermoforming Industry



Lustran® ABS
Lustran® SAN
Centrex® ASA/AES
Triax® PA/ABS
Durethan® Polyamide

For information call
1-800-662-2927

THINK THERMOFORMING

Think Onsrud, #1 Source of Cutting Tools to The Thermoforming Industry

Cutting Tools for ALL Trimming Applications

- Multi-Axis Robotic Routers
- 3 and 5 Axis CNC Routers
- Hand-Held Routers

ONSRUD

ONSRUD CUTTER LP
 800 Liberty Drive
 Libertyville, IL 60048, USA
 Ph: 800.234.1560 • Fax: 847.362.5028

LMT • Leitz Metalworking Technology Group



www.onsrud.com • www.plasticrouting.com

ENSINGER/PennFibre
PENN FIBRE PLASTICS, INC. ~ SINCE 1937
WWW.PENNFIBRE.COM

*Launch your next innovation...
...with one of ours.*

**High Performance
Forming Materials**
by ENSINGER/PennFibre

PA6-6/6
PES
PEI
POM
PPS
PSU
PPSU
PVDF
TPEs
COC

*ESD Formulations ~ Fabric Backings ~ Custom Laminates
Sheets and rolls from .010in.—.250in. thick, widths to 50 inches.*

*Contact us today to see how our High Performance Forming Materials can
create new opportunities in growing markets for demanding applications.*

800-662-7366 penninfo@pennfibre.com

GET READY TO SOAR AT THE 15th Annual Thermoforming Conference



Spreading Our Wings
Milwaukee 2005

September 24-27, 2005

Midwest Airlines Convention
Center
Milwaukee, Wisconsin

*We need
your
continued
support
and
your
efforts
on
membership
recruitment!!*

KMD Series Machine
*High Performance Pressure Forming
for Packaging Parts for a variety of Industries*

KIEFEL
*The experience to
form your future.*

KIEFEL TECHNOLOGIES, INC.
7 Scott Road
Hampton, NH 03842
Tel: 603-929-3900 • Fax: 603-926-1387
www.kiefeltech.com
e-mail kiefel@kiefeltech.com

If you want to lead you have to get in-line.

By far, the most
efficient way to
produce
thermoformed
packaging
is with a Welex
In-Line Extrusion System.

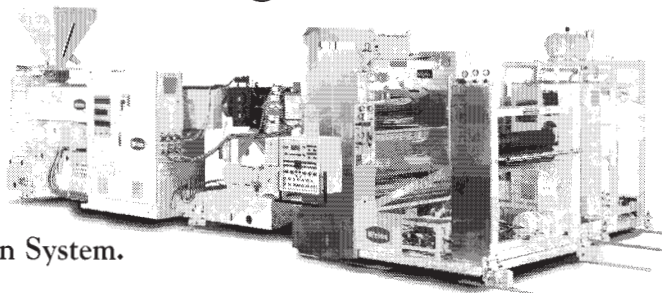

Welex Incorporated
850 Jolly Road, Blue Bell, PA 19422
Tel(215) 542-8000 FAX(215) 542-9841
E-mail: welex@welex.com



The Smart Choice for Vinyl Sheet & Film

- Standard Formulations to Meet Most Requirements
- Standard and Custom Colors
- In-Line Laminating
- Standard Surfaces and Textures Available
- Low Minimum Quantities
- Delivery-Typically 3 weeks or less

Leading the world in
innovation & customer
service



Walton Plastics, Inc.

Call today for a fast quote
1-800-719-9258
440-786-7711 • Fax: 440-232-3187
Cleveland, Ohio

Email: ddrzik@gltcos.com • Web: www.waltonplastics.com

Excellence in CHILL ROLLS



Durashell™ Hardened Chill Roll
— 420 Stainless Steel Overlay
— 48 - 50 Rc Surface Hardness
— High PLI Capable

ContraBend® Chill Roll
— Ideal for Thin Gauge Sheet
— Reverse Deflection Design
— +/-5/10,000" Gauge Variance

**Complete Repair
& Refinishing Services**
— Certified Welding
— In-house Chrome Plating
— 48" Diameter and 300" Lengths

Call one of our Roll Specialists Today!



New Castle Industries
1399 Countyline Road • New Castle, PA 16107

724-656-5600 • 800-897-2830
fax: 724-656-5620 • www.newcas.com



Thermo Forming

Division

Help Sponsor

THERMOFORMING® QUARTERLY

ONE YR. SPONSORSHIPS

**Please note the increase in sponsorship rates. This is the first increase since the inception of the Thermoforming Quarterly in 1981. We appreciate your continued support of our award winning publication.

Patron - \$625

(Includes 2.25" x 1.25" notice)

Benefactor - \$2,000

(Includes 4.75" x 3" notice)

Questions?

Please Contact:

Laura Pichon

Ex-Tech Plastics

815/678-2131 Ext. 624

lpichon@extechplastics.com

We Appreciate Your Support!

From The Editor

Thermoforming Quarterly welcomes letters from its readers. All letters are subject to editing for clarity and space and must be signed. Send to: Mail Bag, Thermoforming Quarterly, P. O. Box 471, Lindale, Georgia 30147-1027, fax 706/295-4276 or e-mail to: gmathis224@aol.com.

GEISS

one step ahead

GEISS INTRODUCES NEW TECHNOLOGY TO THE THERMOFORMING INDUSTRY

Worldwide we are the only specialist to offer complete solutions for plastic processing. At **GEISS** we design and manufacture thermoforming machines, molds, CNC trimming centers and the necessary trimming fixtures. True to our motto "one step ahead" we solve today the tasks of tomorrow.



FLASH heating elements

The **GEISS** heating system utilizes halogen heating elements, which reduces the heating times up to 50% and decreases energy usage by up to 70%.



Adjustable and programmable MOLD FRAME

Mold frame can be adjusted for any mold that can be installed in the machine, which reduces setup time and eliminates the need for individual mold frames. The setup of mold frame is stored in the mold recipe.



CNC Trimming machines with ultrasonic cutting

In addition to conventional trimming with a spindle **GEISS** offers ultrasonic cutting for material that cannot be trimmed by conventional means.

Contact us for a detailed analysis of your current or future thermoforming applications utilizing all or some of the **GEISS** technologies. This analysis is a program that incorporates many parameters and is performed by a **GEISS** representative at no charge.

Geiss Thermoforming USA, LLC; 1831 Howard Street, Suite D; Elk Grove, IL 60007
tel: 847 364 7628
fax: 847 364 7968
internet: www.geiss-ttt.com
email: geissusa@aol.com

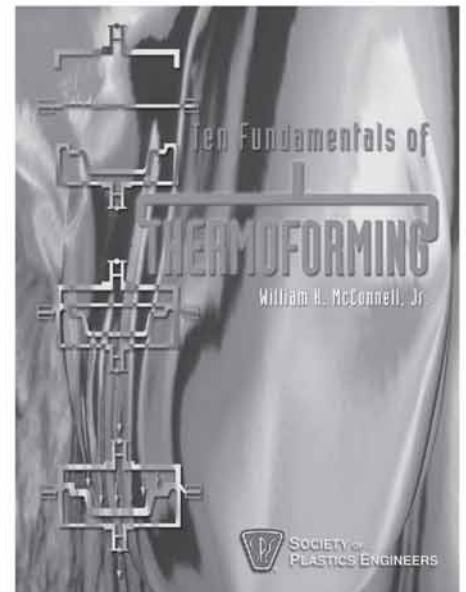

DVD or Video Series & Companion Volume

- Based on Bill McConnell's Seminar and Workshop Series
- Heavy & Thin Gauge Thermoforming
- Methods, Materials, Production, Tooling, Mold/Product Design
- Vacuum and Compressed Air Systems, Best Practices, Heating of Film and Sheet & Heating System Requirements
- Filmed at four plant locations
- 200-page Companion Volume parallels video program and includes useful tables, charts and checklists
- The only Thermoforming Training in the marketplace

Ten Fundamentals of THERMOFORMING

by SPE and Bill McConnell (#0190)

www.4spe.org

email: bookstore@4spe.org

**THERMOFORMERS, HAVE
YOU DISCOVERED A
FORMING TIP THAT YOU
ARE WILLING TO SHARE
WITH YOUR FELLOW
FORMERS?**

A TIME SAVER?

OR A COST SAVER?

OR SOMETHING THAT

**WILL SAVE WEAR AND
TEAR ON YOUR MACHINE?**

OR YOUR EMPLOYEES?

THEN THE

Forming TIPS

COLUMN

IS FOR YOU!

**Just send Jim Throne a fax at
727-734-5081, outlining your
tip in less than a couple
hundred words. You can
include drawings, sketches,
whatever. Thanks!**

"Thermoformers R Us"

America's premier dealer in used equipment is just a click away

*** Thermoformers * Granulators***

*** Extrusion * Appraisals ***

Tel: 800-394-1128 Fax: 845-267-2825

www. *plastIMACH* .com

"Real Time" Inventory including photos, specs & videos

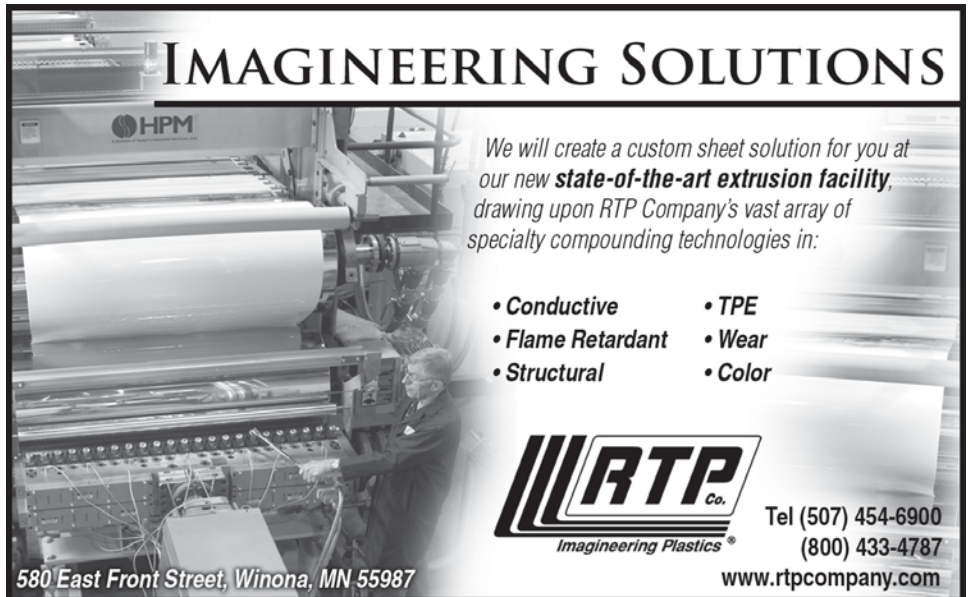

IMAGINEERING SOLUTIONS

*We will create a custom sheet solution for you at our new **state-of-the-art extrusion facility**, drawing upon RTP Company's vast array of specialty compounding technologies in:*

- Conductive
- Flame Retardant
- Structural
- TPE
- Wear
- Color

RTP Co.
Imagineering Plastics®

Tel (507) 454-6900
(800) 433-4787
www.rtpcompany.com

580 East Front Street, Winona, MN 55987

BROWN® Machine



Brown Machine, the industry leader since 1952, continues to expand and offer the most complete line of production thermoforming equipment. From entry-level machinery to advanced system automation, Brown Machine can support any and all of your cut sheet or in-line requirements including:

- Single Station Shuttle Thermoformers
- Vacuum Rotary Thermoformers
- Pressure Rotary Thermoformers
- Steel Rule Thermoformers
- In-Line Thermoformers
- Horizontal & Vertical Trim Presses
- Lip Rollers
- In-Line Tooling & Mold Components
- Remanufacture & Upgrade Kits
- 24/7 Parts & Service

Brown Machine LLC
330 North Ross Street
Beaverton, MI 48612-0434
USA

phone 989.435.7741
fax 989.435.2821
sales@brown-machine.com
www.brown-machine.com

YOU ASKED



WE LISTENED



Due to the many surveys requesting that we change the dates of the annual Thermoforming Conference, the Board has listened and beginning in 2006, we are pleased to announce the new dates.

Nashville 2006



"Creativity & Innovation in Thermoforming"

**Sunday,
September 17
through
Wednesday,
September 20,
2006**

**Renaissance Nashville
Hotel & Nashville
Convention Center**

**General Chairman:
Martin Stephenson
Placon Corporation
Phone: 608-275-7215
E-Mail:
mstep@placon.com**

**Technical Chairman:
Mike Lowery
Premier Plastics
Phone: 414-423-5940 Ext. 102
E-Mail:
mikel@lowerytech.com**

These sponsors enable us to publish **THERMOFORMING QUARTERLY**

QUICK CHANGE CYLINDER LOCKS

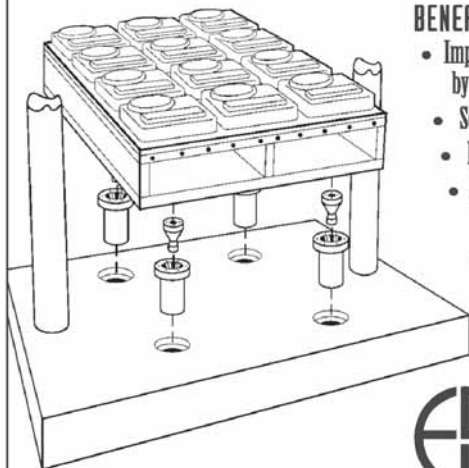

BENEFITS...

- Improve tool change over times... by more than 50%
- Self aligning...precisely repeatable
- No bolts-no wrenches
- Adaptable to all tools and components
- Simple to install



➔ Call for our new catalog

Tel: 937.295.3672 www.segen-online.com



EDWARD D. SEGEN & CO., LLC
A TOOLING TECH GROUP COMPANY
P.O. Box 319, 100 Enterprise Dr., Ft. Loramie, OH 45845



ULTRA-METRIC TOOL CO.

2952 N. Leavitt • Chicago IL 60618 • Ph (773) 281-4200 • Fax (773) 281-6185

THERMOFORM TOOLING



FORM TOOLS

TRIM TOOLS

OPS PET PP HDPE
EPS



PRECISION TOOLS FOR
QUALITY THERMOFORM
PRODUCTS

*We Design & Build Thermoform
Tooling That Molds Relationships*

30+ Years of Superior Service:

- ◆ Complete Turnkey Service
- ◆ Product Design & Prototypes
- ◆ CAD/CAM Tool Engineering
- ◆ Continuous High Speed Tooling
- ◆ 3rd Motion Machine Driven
- ◆ Form & Trim-In-Line
- ◆ Form & Trim-In-Place
- ◆ Custom Built Mold Bases
- ◆ H₂O Cooled Male/Female Molds
- ◆ Matched Metal Punch & Die Sets
- ◆ Large CNC Milling & CNC Turning
- ◆ Deep Hole Gun Drilling
- ◆ On-time Delivery

← sales@umthermoform.com
www.umthermoform.com



Society of Plastics Engineers

PO Box 403, Brookfield, CT 06804-0403 USA
Telephone: +1.203.740.5403 Fax: +1.203.775.8490
www.4spe.org

MEMBERSHIP APPLICATION

Applicant Information

Name: first _____ last _____ mi _____		Home Address: <i>(please provide)</i> address: _____ address: _____ city: _____ state: _____ zip: _____ country: _____	
Applicant Type: <input type="checkbox"/> Member <input type="checkbox"/> Student (must supply graduation date _____)		Preferred Mailing Address: <input type="checkbox"/> Home <input type="checkbox"/> Business	
Job Title: _____		Job Function: <i>(choose only one)</i> <input type="checkbox"/> Consulting <input type="checkbox"/> Design <input type="checkbox"/> Education <input type="checkbox"/> General Management <input type="checkbox"/> Library <input type="checkbox"/> Manufacturing <input type="checkbox"/> Marketing/Sales <input type="checkbox"/> Purchasing <input type="checkbox"/> Quality Control <input type="checkbox"/> R & D <input type="checkbox"/> Retired <input type="checkbox"/> Student <input type="checkbox"/> Tech Support <input type="checkbox"/> Other	
Company Name and Business Address (or College): company/college: _____ address: _____ address: _____ city: _____ state: _____ zip: _____ country: _____		Gender: <input type="checkbox"/> Male <input type="checkbox"/> Female	
Work Phone: () _____ Fax: () _____		Birth Date: (mm/dd/yyyy) _____	
Home Phone: () _____		The SPE Online Membership Directory is included with membership. Your information will automatically be included. <input type="checkbox"/> Exclude my email from Online Member Directory <input type="checkbox"/> Exclude all my information from Online Member Directory <input type="checkbox"/> Exclude my address from all 3rd party mailings	
Email: <i>used for society business only</i> _____			

Payment Information

New Member 1 Year <input type="checkbox"/> US (\$120.00) <input type="checkbox"/> Canada (\$160.00) <input type="checkbox"/> Euro (€123.00)	New Member 2 Years * <input type="checkbox"/> US (\$208.00) <input type="checkbox"/> Canada (\$277.50) <input type="checkbox"/> Euro (€215.00)	Student Member <input type="checkbox"/> US (\$28.00) <input type="checkbox"/> Canada (\$37.50) <input type="checkbox"/> Euro (€24.00)	Membership Amount _____												
My Primary Division is (Division names are below) _____			Primary Division FREE												
Additional Divisions are available for a fee. Check below to select Additional Divisions. <input type="checkbox"/> Automotive (D31) <input type="checkbox"/> Mold Making & Mold Design (D35) <input type="checkbox"/> Blow Molding (D30) <input type="checkbox"/> Plastics Environmental (D40) <input type="checkbox"/> Color & Appearance (D21) <input type="checkbox"/> Polymer Analysis (D33) <input type="checkbox"/> Composites (D39) <input type="checkbox"/> Polymer Modifiers & Additives (D38) <input type="checkbox"/> Decorating & Assembly (D34) <input type="checkbox"/> Product Design & Development (D41) <input type="checkbox"/> Electrical & Electronic (D24) <input type="checkbox"/> Rotational Molding (D42) <input type="checkbox"/> Engineering Properties & Structure (D26) <input type="checkbox"/> Thermoforming (D25) <input type="checkbox"/> Extrusion (D22) <input type="checkbox"/> Thermoforming, European (D43) <input type="checkbox"/> Flexible Packaging (D44) <input type="checkbox"/> Thermoplastic Materials & Foams (D29) <input type="checkbox"/> Injection Molding (D23) <input type="checkbox"/> Thermoset (D28) <input type="checkbox"/> Marketing & Management (D37) <input type="checkbox"/> Vinyl Plastics (D27) <input type="checkbox"/> Medical Plastics (D36)			Additional Division(s) _____ cost for each Additional Division <table border="1"> <tr><th></th><th>1 year</th><th>2 years</th></tr> <tr><td>US</td><td>\$6.00</td><td>\$12.00</td></tr> <tr><td>Canada</td><td>\$8.00</td><td>\$16.00</td></tr> <tr><td>Euros</td><td>€5.00</td><td>€10.00</td></tr> </table>		1 year	2 years	US	\$6.00	\$12.00	Canada	\$8.00	\$16.00	Euros	€5.00	€10.00
	1 year	2 years													
US	\$6.00	\$12.00													
Canada	\$8.00	\$16.00													
Euros	€5.00	€10.00													
			TOTAL _____												

CHECK VISA AMEX MASTERCARD

card number _____

expiration date (mm/yyyy) _____

PAYMENT MUST ACCOMPANY APPLICATION
Sorry, No Purchase Orders Accepted

Checks must be drawn on US or Canadian banks in US or Canadian funds.
Dues include a 1-year subscription to *Plastics Engineering* magazine.
SPE membership is valid for twelve months from the month your application is processed.
*save over 10%

By signing below I agree to be governed by the Constitution and Bylaws of the Society and to promote the objectives of the Society. I certify that the statements made in the application are correct and I authorize SPE and its affiliates to use my phone, fax, address and email to contact me.

signature _____ date _____

recommended by member (optional) _____ id # _____

D 04

These sponsors enable us to publish
**THERMOFORMING
QUARTERLY**



MILLER MOLD COMPANY
Serving The Thermoforming
Industry Since 1951
3320 Bay Road
Saginaw, MI 48603

TIM WELDON
General Manager
(989) 793-8881
Fax (989) 793-8888

Email: timweldon@miller mold.com



**50 YEARS PROVIDING
SOLUTIONS
IN PLASTICS**

McClarin Plastics, Inc.
800-233-3189
717-637-2241 • Fax: 717-637-2091
600 Linden Avenue
Hanover, PA 17331
www.McClarinPlastics.com
E-Mail: mcclarin@mcclarinplastics.com

**PRIMEX
PLASTICS CORPORATION**
A Quality Custom Sheet Extruder!

Polystyrene Polyethylene ABS
Polypropylene Polyester Cor-x

1-800-222-5116
www.primexplastics.com

Large enough to handle your requirements,
Small enough to handle your needs...

**ZED
INDUSTRIES, INC**

Thermoforming & Plastic Packaging Machinery

Mark T. Zelnick

3580 Lightner Road TEL (937) 667-8407
PO Box 458 FAX (937) 667-3340
Vandalia, OH 45377 E-mail: info@zedindustries.com

ALLEN
CUSTOM THERMOPLASTIC SHEET

1305 Lincoln Avenue, Holland, MI 49423
PH (800) 833-1305 / FX (800) 832-5536
www.allenx.com

ABS ABSFR PCABS
HIPS HIPSFR GELOY
CENTREX LURAN NORYL
SOLARKOTE

A Tradition of Excellence Since 1970

These sponsors enable us to publish **THERMOFORMING QUARTERLY**

New

HYTAC[®] -FLX Tough & Flexible Plug Assist Material

Proven performance from the company dedicated to thermoforming.

- Superb Customer Service
- Technical Support
- Largest Material Selection & Inventory



CMT MATERIALS, INC.
info@cmtmaterials.com www.cmtmaterials.com
TEL (508) 226-3901 FAX (508) 226-3902

**WORLD CLASS
EXTRUSION SYSTEMS**

- ✓ STANDARD AND CUSTOM CONFIGURATIONS
- ✓ COMPACT INLINE, FULL LENGTH AND CUT SHEET SOLUTIONS

FROM FUEL TANKS...
...TO CUPS & LIDS
AND EVERYTHING IN BETWEEN...

**PTI HAS THE RIGHT
SOLUTION FOR YOU!**

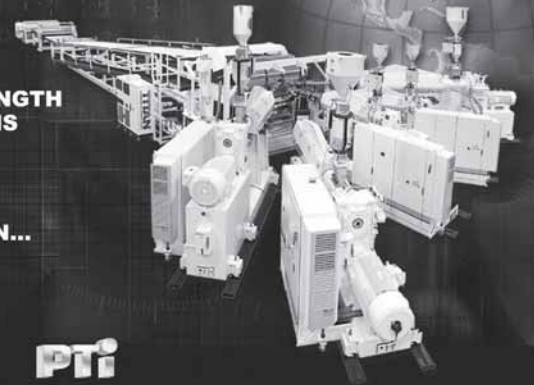

PTI
PROCESSING TECHNOLOGIES, inc.
2655 White Oak Circle | Aurora, IL 60504 | Ph: 630.585.5800 | Fx: 630.585.5855
www.ptiextruders.com

PRODUCTO
PROGRESS BY DESIGN

**Precision
Thermoform
Tooling**

When it comes to answering your need for quality thermoform tooling, you can't find a better source than Producto.

- Complete turnkey service
- Tooling machined and assembled with precision
- Deliveries to suit your schedules
- Mold beds up to 70" x 120"

- Engineering design using the latest CAD systems and programming technologies
- Gun drilling services and Temperature Control Plates
- Adjustable Pressure Boxes
- Die sets, punches and dies, springs, pins & bushings and a full line of quality accessory items

Producto Corporation
800 Union Ave., Bridgeport, CT 06607
(203) 367-8675
FAX: (203) 368-2597

These sponsors enable us to publish
**THERMOFORMING
QUARTERLY**

FUTURE MOLD CORP.
215 S. Webber Street, Farwell, MI 48622
(989) 588-9948 ♦ (989) 588-6170 Fax

THERMOFORMING TOOLS
CUP LIP ROLLERS

MIKE OTTO, SALES MANAGER

www.futuremoldcorp.com
motto@futuremoldcorp.com

SELECT PLASTICS, LLC.
EXTRUDED SHEET

7224 Burns St. Metro (817) 595-3804
Fort Worth, TX 76118 FAX (817) 595-4050
(877) 501-2530

Donald H. Hudson President

RAY Brian Ray
brianr@rayplastics.com
1700 Chablis Avenue
Ontario, CA 91761
909/390-9906
800/423-7859
FAX 909/390-9896
www.rayplastics.com

PRODUCTS / INC
.....plastics

**The Experts in
Thermoforming**

**MODERN
MACHINERY**
OF BEAVERTON, INC.

CUSTOM CUT SHEET & ROLL FED MACHINERY
OVEN, CONTROL & INDEX RETROFIT KITS
PATENTED ADJUSTABLE CLAMP FRAMES

3031 GUERNSEY ROAD, BEAVERTON, MI
PH: 989-435-9071 FAX: 989-435-3940
Email: info@modernmachineinc.com

TPS THERMOFORMER
PARTS
SUPPLIERS

Lightning fast response to your maintenance needs.
Call for your "NEW" 2005 Parts Guide

www.thermoformerparts.com

1-800-722-2997 Same Day Shipping
or 989-435-3800 til 4:00pm EST
Fax - 989-435-3825 Monday - Friday

Standex ENGRAVING GROUP Worldwide Specialists in Textured Rolls,
Plates, Blanks and Engineered Machinery

Paul Lapointe

Standex Engraving Group
5901 Lewis Rd.
Sandston, VA 23150

Ph: 804/236-3065
Fax: 804/226-3462

These sponsors enable us to publish **THERMOFORMING QUARTERLY**

SPARTECH **Spartech Plastics**
Custom Sheet & Rollstock

Your Source for Innovative Plastic Solutions

27 Spartech Plastic Locations

Broadest Product Portfolio in the Extrusion Industry Including:

ABS	HDPE	Polypropylene
Acrylic	Polycarbonate	Weatherable ABS
Corrugated Sheet	PETG	High Impact Styrene

SPARTECH ALLOYplastics™ **888-721-4242**
www.spartech.com

MAAC
THERMOFORMING MACHINERY

THE NEW MAAC!

Leader in Twin-Sheet
Pressure Forming
Technology!

- Single Stations
- Double Enders
- Three-Station Rotaries
- Four-Station Rotaries
- Oven-Over
- Custom Machines

*Larger Mainframes *All Encoder Positioning
*Bigger Motors *Adjustable Clampframes
*Faster Drives *Guaranteed Cycle Times

Comet
4-Week Deliveries!

WWW.MAACMACHINERY.COM
590 Tower Blvd, Carol Stream, IL 60188, Tel: (630) 665-1700

STRENGTH & PRECISION

**ARES ... CNC
MACHINING
CENTERS FOR
MACHINING
PLASTIC AND
COMPOSITE
MATERIALS**

Visit us on the web at:
www.cmsna.com
www.cms.it
or email us at
cmssales@cmsna.com

CMS NORTH AMERICA, INC.
Grand Rapids, MI
800.225.5267

INDEX OF SPONSORS

ADVANCED VENTURES IN TECHNOLOGY, INC.	26	ENSINGER/PENN FIBRE	28	LAND INSTRUMENTS	9
ALLEN EXTRUDERS	34	FILTRONA EXTRUSION	25	LANXESS	27
AMERICAN CATALYTIC TECHNOLOGIES	8	FOXMOR GROUP	25	LYLE	5
ARISTECH ACRYLICS	23	FUTURE MOLD CORP.	35	MAAC MACHINERY	35
ALTUGLAS INTERNATIONAL	24	GEISS THERMOFORMING	30	McCLARIN PLASTICS	34
BROWN MACHINE	31	GN PLASTICS	27	McCONNELL CO.	9
CMS NORTH AMERICA	35	IRWIN RESEARCH & DEVELOPMENT	6	MILLER MOLD CO.	34
CMT MATERIALS, INC.	34	JRM INTERNATIONAL	23	MODERN MACHINERY	35
EDWARD D. SEGEN & CO.	32	KIEFEL TECHNOLOGY	28	NEW CASTLE INDUSTRIES	29
		KYDEX	36	ONSRUD CUTTER	27
				PLASTICS CONCEPTS	4
				PLASTIMACH	31
				PORTAGE CASTING & MOLD, INC.	9
				PREMIER MATERIAL CONCEPTS ..	9
				PRIMEX PLASTICS	34
				PROCESSING TECHNOLOGIES ..	34
				PRODUCTIVE PLASTICS, INC.	9
				PRODUCTO CORPORATION	34
				PROFILE PLASTICS	9
				PROTHERM	25
				RAY PRODUCTS, INC.	35
				RTP	31
				SELECT PLASTICS	34
				SENCORP	36
				SOLAR PRODUCTS	1
				SPARTECH PLASTICS	35
				STANDEX ENGRAVING GROUP ..	35
				STOPOL INC.	24
				TEMPCO ELECTRIC	8
				THERMWOOD CORP.	Inside Back Cover
				TOOLING TECHNOLOGIES, LLC	23
				TPS	35
				ULTRA-METRIC TOOL CO.	32
				WALTON PLASTICS	29
				WECO PRODUCTS	25
				WELEX, INC.	29
				ZED INDUSTRIES	34

These sponsors enable us to publish **THERMOFORMING QUARTERLY**

SOLVE COST & PERFORMANCE PROBLEMS

- ◆ Over 40 specialized grades satisfy highest performance to lowest cost applications:
 - Aircraft
 - Mass transit
 - Building products
 - Weatherable
 - Conductive/ESD
 - Multi-purpose

- ◆ 10 Surface Textures

- ◆ Thickness from 0.028" to 0.500"

- ◆ Certified Fire Ratings:
 - UL Std. 94 V-0 and 5V
 - UL 746C for signage
 - FAR 25.853(a) and (d)
 - Class 1/A
 - MVSS 302
 - ASTM E-662/E-162

- ◆ Broad Color Selection:
 - 34 Standard colors
 - 2000+ Custom colors
 - Granite patterns
 - Fluorescent colors
 - Woodgrain patterns

Kleerdex Company, LLC
6685 Low Street
Bloomsburg, PA 17815 USA
Tel: 800-325-3133
Fax: 800-452-0155
E-mail: info@kleerdex.com

www.kydex.com

KYDEX®

ISO 9001:2000 and
ISO 14001 CERTIFIED

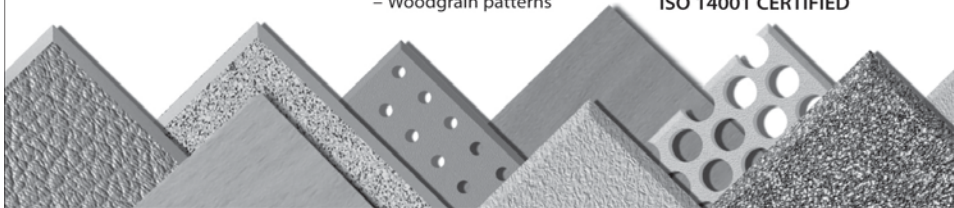

We build machines that build business.™



- Sencorp & Armac In-Line Thermoforming Systems
- CeraPak Blister Packaging Systems
- CeraTek Laboratory Heat Sealers
- Master Tooling Systems
- Machine Retrofits & Rebuilds
- Complete Turnkey System Integration
- Build To Print
- Serving Automotive, Medical, Pharmaceutical, Consumer and Custom Forming Markets

SENCORP™
We build machines that build business.

tel. +1 508 771 9400 fax +1 508 790 0002 email: sales@sencorp-inc.com

web: www.sencorp-inc.com