

# Thermoforming 2006

## 16th Annual Thermoforming Conference

September 17th – 20th, 2006

Nashville 2006



**"Creativity & Innovation  
in Thermoforming"**



**NASHVILLE CONVENTION  
CENTER**

**RENAISSANCE HOTEL**

**NASHVILLE, TENNESSEE**

**For More Information:**

**Conference Chairman: Dr. Martin Stephenson, Placon Corporation**  
608.275.7215 Fax 608.278.4423  
[mstep@placon.com](mailto:mstep@placon.com)

**Technical Chairman: Mike Lowery, Premier Plastics**  
414.423.5940 Fax 414.423.5930  
[mikel@lowerytech.com](mailto:mikel@lowerytech.com)

**Parts Competition Chairman: James Alongi, Maac Machinery**  
630.665.1700 Fax 630.665.7799  
[jalongi@maacmachinery.com](mailto:jalongi@maacmachinery.com)

**Conference Coordinator: Gwen Mathis**  
706.235.9298 Fax 706.295.4276  
[gmathis224@aol.com](mailto:gmathis224@aol.com)

**CHECK OUT OUR WEBSITES AT:**  
<http://www.4spe.org/communities/divisions/d25.php>  
[www.thermoformingdivision.com](http://www.thermoformingdivision.com)



**Martin Stephenson**

## “CREATIVITY & INNOVATION IN THERMOFORMING”

Nashville, Tennessee

September 17th – 20th, 2006



“Creativity & Innovation  
in Thermoforming”

I would like to take this opportunity to invite you to the 16<sup>th</sup> Annual SPE Thermoforming Conference to be held in “Music City” – Nashville, Tennessee. Many of you have requested a Sunday evening start as opposed to the usual Saturday night. In response to this request, the 2006 Conference will kick off on Sunday evening, September 17th and go through Wednesday, September 20th, 2006 with a theme of “Creativity and Innovation in Thermoforming.” This will be our third time in the “Music City” and we are glad to be back in Nashville! The 1998 and 2002 conferences were well attended and highly rated and we know that the 2006 Conference will be no exception!

Planning for the conference has already begun. Mike Lowery (Premier Plastics), Technical Chair for 2006, and I are very excited about the direction of our program. We have already lined up speakers from North America and Europe to conduct both seminars and joint sessions. Many people in our industry are very creative and innovative and we are working to bring them to speak in Nashville. Topics we will cover will be competing in today’s hotly competitive global market, dealing with issues of cost vs. value, and the technical aspects of innovations in the Thermoforming Industry, i.e. material processing, tooling technology, and machinery. This is an excellent forum to launch your new products and conduct business with the leaders of the thermoforming industry.

The convention center in Nashville is a very dynamic location with friendly people to tailor to your needs. We think 2006 will be our largest show ever, so reserve your space now to exhibit. If your company has never sponsored before, we invite you to look at the value one gets by sponsoring. We do have a lottery to draw the sponsors due to the response we get each year. It is a great value! Even if you are not drawn as a sponsor, you will move down to the top of the list to select your exhibit space. Our SPE Thermoforming Board is grateful for the continuous support our sponsors and exhibitors give us each year. We could not do it without you!

Nashville is a very economical venue so that companies can bring CEOs, Sales/Marketing Executives, along with their Engineering and Operations people. This year’s Conference aims to have a particular orientation toward the men and women in the trenches (Engineering and Operations) of the Thermoforming Industry.

It is never too soon to reserve your space for 2006. Gwen Mathis, Conference Coordinator, is happy to help you. Please call her at 706.235.9298, (fax) 706.295.4275 or e-mail: [gmathis224@aol.com](mailto:gmathis224@aol.com).

The bands are warming up and awaiting your arrival to the Music City. I am ready and hope to see you in Nashville for a successful Conference in 2006! ■

# FIRST CALL FOR SPONSORS/EXHIBITORS

## 16th Annual Thermoforming Conference & Exhibition

September 17th - 20th, 2006

### NASHVILLE CONVENTION CENTER

Nashville, Tennessee

Gwen Mathis, Conference Coordinator

## “THERMOFORMING 2006: CREATIVITY & INNOVATION IN THERMOFORMING”

**T**he 16th Annual Thermoforming Conference and Exhibition – “Thermoforming 2006: Creativity & Innovation in Thermoforming” – plans are beginning to take shape. This show will be a forum for the newest techniques, latest equipment, materials, auxiliary equipment and current industry news. As an Exhibitor, this event will enable you to showcase your products and services at the only show geared just to **THERMOFORMERS!** If your company sells to **THERMOFORMERS**, then this is the place you must be. This industry event is a prime opportunity for you to reach the decision makers in the field and create a brighter future for your business as well.

Full exhibits will be offered. Our machinery section continues to grow each year. If you are not participating in our machinery section, you are encouraged to do so. Each 10' x 10' booth is fully piped, draped, carpeted and a sign will be provided. As an extra value, one comp full registration is included with every booth sold. This gives your attendees access to all **Technical Sessions, Workshops, Special Events, Plant Tours and all meals. A great bargain at \$2,250.00.**

Where else can you make personal contact with more than 1,000 individuals who are directly involved with our industry. Your **SPONSORSHIP** or participation as an **EXHIBITOR** has demonstrated its potential to help your sales and it is contributing to the strength and success of our industry as a whole.

We urge you to join us at **THERMOFORMING 2006 in Nashville!** Reserve your space early to avoid disappointment. Booth assignments are made on a first come, first serve basis.

Should you have questions, please call (706) 235-9298, fax (706) 295-4276  
or e-mail to [gmathis224@aol.com](mailto:gmathis224@aol.com).

# EXHIBIT GUIDELINES

## EXHIBITOR PACKAGE: \$2,250

10' x 10' Booth, Piped, Drape, Sign and Carpet provided.  
Additional booth spaces: 2nd \$2,000, 3 or more \$1,750 each.

All Exhibit packages include the cost of (1) Full Conference registration which includes all meals to a company representative. One is given for each booth purchased. All additional attendees must be registered and pay full conference registration to staff your exhibit.

Exhibitors must arrange for any additional services or needs in advance with the designated decorating service. Exhibitor packet will be sent no later than June 1st, 2006.

Parts Competition and Plastics Van to be located in Exhibit area.

Ribbon Cutting Opening Exhibits on Sunday, September 17th, 2006 followed by Welcome Reception on Exhibit floor.

DEADLINE FOR CANCELLING EXHIBIT SPACE WITH REFUND IS JUNE 1st, 2006. No refunds available after June 1st, 2006.



# 2006 THERMOFORMING CONFERENCE

## Creativity & Innovation in Thermoforming

September 17th - 20th, 2006  
Nashville, Tennessee



### EXHIBITOR REGISTRATION FORM

(Please complete and return with your check today.)

\_\_\_\_\_ YES, we want to be a 2006 Thermoforming Exhibitor. Enclosed is our check for \$2,250. Additional 10' x 10' booths as needed will be 2nd \$2,000, 3 or more \$1,750 each. We will require \_\_\_\_\_ Booths. We understand that space assignments will be assigned after Sponsors have been selected. Cancellations will be accepted up to June 1st, 2006.

COMPANY NAME: \_\_\_\_\_

CONTACT: \_\_\_\_\_ SIGNATURE: \_\_\_\_\_

ADDRESS: \_\_\_\_\_

CITY/STATE/ZIP: \_\_\_\_\_

PHONE: \_\_\_\_\_ FAX: \_\_\_\_\_ E-MAIL: \_\_\_\_\_

To properly plan exhibit or badge needs, please list everyone who will be attending. For each exhibit space purchased, a complimentary registration is included (\$295 value). All other persons must be registered for the full conference which includes all meals.

Name: \_\_\_\_\_ Name: \_\_\_\_\_

Name: \_\_\_\_\_ Name: \_\_\_\_\_

MAKE CHECKS PAYABLE TO: 2006 SPE THERMOFORMING CONFERENCE

MAIL TO: GWEN MATHIS, CONFERENCE COORDINATOR  
SPE THERMOFORMING DIVISION  
P. O. BOX 471, 124 AVENUE D, SE  
LINDALE, GEORGIA 30147-0471  
FAX (706) 295-4276

# 2006 Thermoforming Conference EXHIBITORS

(Signed Up at Press Time)

## “Creativity & Innovation in Thermoforming”

\* DENOTES 2006 SPONSORS

*If your company name is not listed here, please get your form in to reserve your space. Contact Gwen Mathis at 706.235.9298.*

### COMPANY

- \* Alcoa Kama Corporation
- \* Allen Extruders
- \* American Tool & Engineering, Inc.
- \* Aristech Acrylics LLC
- \* Brown Machine LLC
- \* Castek Aluminum  
Ensinger/Penn Fibre
- \* ExTech Plastics
- \* Geiss Thermoforming USA LLC
- \* Kiefel Technologies, Inc.  
Klockner Pentaplast
- \* Land Instruments International
- \* Maac Machinery Company
- \* New Hampshire Plastics
- \* Onsrud Cutter  
Plastimach Corporation
- \* Portage Casting & Mold, Inc.
- \* Premier Material Concepts
- \* Primex Plastics Corporation

### COMPANY

- \* PTi (Processing Technologies, Inc.)  
Producto Company
- \* Raytek Corporation
- \* Robotic Production Technology
- \* Sencorp, Inc.
- \* Senoplast USA  
Society of Plastics Engineers
- \* Spartech Plastics  
Stopol, Inc.  
Thermoformer Parts Suppliers
- \* Thermwood Corporation
- \* Tooling Technology LLC
- \* Total Industries International  
Zed Industries

# 2006 THERMOFORMING CONFERENCE

## *Creativity & Innovation in Thermoforming Tentative Technical Program Announced Nashville Convention Center*

**MONDAY,  
SEPTEMBER 18th, 2006**

***Mini-Seminar in Advanced Topics in Thermoforming - 3 Hours (Limited to 25 attendees) - Dr. James Throne, Sherwood Technologies, Inc.***

This 3-hour advanced seminar is designed for the technologist who needs to know how the major engineering aspects such as heat transfer, rheology, interfacial mechanics, and fracture mechanics are applied to thermoforming.

Attendees should consider this as a graduate-level seminar that assumes a thorough undergraduate working knowledge of engineering concepts and mathematics through calculus. If you do not have this background, do not attend.

Please note that attendance is restricted to 25. A waiting list will be available for late registrants.

There will be no handout. Attendees may download the instructor's PPT slides via their personal memory sticks at the end of the seminar.

Not all topics given in the following list will be covered, additional topics may be added, and those that will be covered will be at the discretion of the instructor.

- The Technology of Sheet Heating
  - Understanding the Fundamentals Behind the Energy Dome
  - Radiant Transparency
  - Heating Sagging Sheet
- Mechanics of Sheet Stretching
  - Elastic Modulus and the Forming Window
  - Catenary and Elliptical Catenoid Models for Sag
  - K-BKZ Model – What and Why?
  - Melt Strain Hardening and the Stress Growth Function
  - Finite Element Analysis and Other Methods of Determining Wall Thickness
- Mechanics of Plug Assist
  - Plane Strain vs. Biaxial Strain
  - Plug-Sheet Interfacial Concerns
- Trimming as Fracture Mechanics

***“Development in Infrared Lamp Technology for Thermoforming” - Jerome Martinache, ITM-Application Group Leader, Phillips Special Lighting***

***“Match Metal Trim for Thin Gauge” - Bill Hilts, Ontario Die Corporation***

***“Technology Does Not Have to be Expensive” - Scott Crandall, Director of***

***Quality & Advanced Technology, McClarin Plastics, Inc.***

***“Mold Temperature Control” - TBD***

***“Legislative Update” - TBD***

***“Business/Casualty Insurance Issues in the Thermoforming Industry” - TBD***

***“Product/Company Branding” - TBD***

***“Innovation: The Risks and Rewards” - TBD***

***“Global View of the Resin Market” - TBD***

**TUESDAY,  
SEPTEMBER 19th, 2006**

***“Improving the Thermoformability of Polypropylene by Modification of the Crystal Phase” - Dr. Phil Jacoby, Vice President of Technology, Mayzo Corporation***

***“Trends in Thermoform-Tooling in Europe” - Hubert Kittelmann, Marbach***

***“Heaters: How, When, Cost” - Frank Wilson, WECO and Ceramicx - Ireland***

***“Measuring Plug to Sheet Interactions During the Thermoforming Process” - Noel Tessier, CMT Materials; Tom Gallagher, Sunoco Chemicals***

***“Bio-Materials Outlook” - TBD***

***“Bringing PHB to the Plastics Industry: A New Family of High Performing Environmentally Friendly Plastics” - Daniel Gilliland, Metabolix***

# Workshops

## 2006 Thermoforming Conference Nashville, Tennessee

*\*\* Attendees can only select one of the four workshops being offered.  
You must register for the conference to attend workshops. \*\**

**SUNDAY,  
SEPTEMBER 17th, 2006**

**RENAISSANCE HOTEL - MUSIC CITY BALLROOM**  
**8:30 a.m. - 3:00 p.m. – McConnell -**  
***Buckel Cut Sheet Workshop***



Bill McConnell



Art Buckel

### I. INTRODUCTION

- Advantages and Disadvantages of the Thermoforming Process

### II. HEATING REQUIREMENTS

- A. The Thermoforming Environment
- Plant & Warehouse
  - Machine Locations
  - Environment Around Machines
- B. Types of Heat – Advantages & Disadvantages
- Convection
  - Conduction
  - Radiation
  - How to Obtain Uniform and/or Profiled Sheet Temperature
  - “K” Factors and Relative Rates of Heat Transfer
  - Regrind & Heat

### III. VACUUM & COMPRESSED AIR SYSTEMS

- C. Vacuum Requirements
- Why Fast Vacuum Needed
  - Vacuum Pressure Measurements
  - Surge Tanks
- D. Compressed Air Requirements
- E. Hydraulic Platens

### IV. FORMING TECHNIQUES – BASIC THERMOFORMING METHODS

- A. Vacuum Forming

- B. Pressure Forming
- C. Mechanical Forming
- D. Prestretch Forming – For Better Material Distribution
- Vacuum Snapback
  - Plug Assist
  - Chamber Forming
- E. Twin Sheet Forming
- F. WRAP UP

Limited to 150 - you must register to attend.

### RENAISSANCE HOTEL - FISK ROOM

**9:00 a.m. - 4:00 p.m. – Throne Roll Fed**  
***Workshop***

This basic workshop introduces the various aspects of thin-gauge thermoforming, from materials to machinery, from processing aspects through trimming, to part and old design. A workshop notebook will be provided.

The following will be discussed:

1. General aspects of thin-gauge thermoforming
2. Machine elements
3. Materials
  - Polymers
  - Additives
4. New materials to be considered
  - Biopolymers
  - Nanocomposites
5. The importance of sheet extrusion parameters
6. Heating the sheet
7. Forming the sheet
8. Trimming
9. Molds and mold design
  - Mold materials
  - Plug materials
10. Part design concepts
  - Wall thickness determination
  - Corners
  - Coining
  - Plug design



# Workshops

## 2006 Thermoforming Conference Nashville, Tennessee

*\*\* Attendees can only select one of the four workshops being offered.  
You must register for the conference to attend workshops. \*\**

11. Regrind considerations
12. Foam forming
13. Production monitoring and control  
    Temperance  
    Birefringence
14. Lingering concerns



**James L. Throne:** Jim Throne is President, Sherwood Technologies, Inc., Dunedin, FL., a consultancy focusing on advanced plastics processing technologies, including thermoforming, foam processing and rotational molding. He is Fellow of the SPE and Fellow of IoM<sup>3</sup> (England). He was SPE Thermoformer of the Year 2000. He was honored by the SPE European Thermoforming Division 2004 for his technical contributions to the worldwide thermoforming industry. He has published 10 books in polymer processing, including four in thermoforming. He holds nine U.S. patents, including a fundamental one in thermoforming CPET. He has written more than a dozen technical book chapters and has published and presented nearly 200 technical papers. He is current Technical Editor of SPE Thermoforming Quarterly. He is Fellow of the Society of Plastics Engineers and Fellow of Institute of Materials, Mining and Manufacturing (IoM<sup>3</sup>).

Limited to 150 - you must register to attend.

### **RENAISSANCE HOTEL - BELMONT ONE ROOM 9:00 a.m. - 12:00 p.m. – Process Controls Workshop - “Improve Production Capacity of Your Equipment: Use Updated Controls”**

Thermoformer life can be extended and better-quality product can be produced with updated control systems. Learn how temperature, gauge, speed, pressure and downstream equipment can all run based on a product code, with adjustments made automatically based on set points and closed-loop control

algorithms (including shot cycle, platen movement, gauge/profile and temperatures). Your firm can reduce scrap, boost throughput, improve quality and consistency with improved controls and by identifying changes with trend charts/graphs and alarming. Data collection is also useful for on-line troubleshooting/diagnostics. This seminar will show you how.



**Michelle Curenton:** Michelle currently serves as a Sales/Product Engineer with FACTS, Inc., a supplier of closed-loop controls systems for extruders, mixers, calenders and thermoformers. She has spent ten years with the company, which exclusively serves the plastics and rubber industries. During this time she has worked as a project and process engineer, managed many start-up projects and custom installations, and routinely helps clients with trouble-shooting or diagnostic issues. She is often called upon to support the company with technical presentations and has presented several papers at industry conferences and SPE meetings. Michelle holds an electrical engineering degree from The University of Akron. Prior to joining FACTS, she worked for a leading company in the steel industry in several engineering roles. In addition to electrical/project engineering skills, she has a strong IT background and combines process data with a clear understanding of software/hardware capabilities, including ERP and SPC applications. She specializes in identifying clients' processing issues and providing realistic solutions for improved technology and manufacturing practices. Michelle is married and the mother of a son. She resides in NE Ohio and routinely travels the country to work with clients on a variety of integrated line-control projects for plastics or rubber manufacturing.

Limited to 50 - you must register to attend.

# Workshops

## 2006 Thermoforming Conference Nashville, Tennessee

*\*\* Attendees can only select one of the four workshops being offered.  
You must register for the conference to attend workshops. \*\**

### RENAISSANCE HOTEL - BELMONT ONE ROOM 1:00 p.m. - 4:00 p.m. – *How to Do Business in India Workshop*

The global economy has mandated international partnerships, India and China emerging as two strong partners. It is in the best interest of our manufacturing industry to at least be aware of what is happening in India and to understand several ways in which we can do business together. The seminar will cover issues related to doing business with/in India including but not limited to Reasons for Exploring Business Opportunities in India, Market Opportunities for U.S. Firms in India, State of Indian Manufacturing, State of Indian Services Sector, Business Destination - Economic and Political, India's Socio-Cultural Heritage, Challenges to Doing Business in India, U.S. Perception of India's Future, Future Directions and India's Economic Policies, Etc. A few case studies will be discussed to learn from experiences.



**Dr. Promod Vohra:** Dr. Vohra is the dean of the College of Engineering and Engineering Technology (CEET). Dr. Vohra is a graduate faculty and a full professor in the Department of Technology. Prior to becoming the dean he was the associate dean for six years where he boosted enrollment in the college by 45 percent over the last seven years. Before that he was the electrical engineering technology (EET) coordinator in the Department of Technology. Dr. Vohra, in addition to having a doctorate in Instructional Technology (with cognate in Industrial Engineering), has a Masters as well as a Bachelors degree in Electrical Engineering. The BS degree was earned from Delhi College of Engineering, India and the latter two degrees were earned at NIU in 1988 and 1993, respectively. Prior to coming to the field of academia, he worked in industry (Philips) for five years as a technical support engineer. He joined NIU in 1988 as a lecturer, became an assistant professor in 1993, an associate professor in 1995 and the associate dean in 1997.

His interest areas are digital systems, instruction design, industrial training, new technologies and applications of technologies. As the coordinator of the Electrical Engineering Technology (EET) program (1988-1995), he increased the program enrollment more than 800 percent, published several refereed articles and brought in about a million dollars worth of equipment grants to develop and expand EET laboratories. He recently brought in software and other grants worth approximately 22 million dollars. Dr. Vohra has been very active in university service and in regional and national professional committees/organizations. He was the recipient of the 1988 Outstanding Young Alumnus Award in 1995, he was given the Excellence in Undergraduate Teaching Award by Northern Illinois University and in 1996 he received the Outstanding Professor Award in the region (seven professional registrations such as a professional engineering (PE) and a senior certified industrial technologist (CSIT)).

Limited to 35 - you must register to attend.

### Nashville Scenes



GRAND OLE OPRY



COUNTRY MUSIC  
HALL OF FAME  
& MUSEUM



JACK DANIEL  
DISTILLERY

# *Workshops*

## **2006 Thermoforming Conference Nashville, Tennessee**

*\*\* Attendees can choose one only. \*\**

**WEDNESDAY, SEPTEMBER 20th, 2006**

**RENAISSANCE HOTEL - RYMAN ROOM**

**8:30 a.m. - 3:00 p.m. – Extrusion Workshop**

***Presented by the SPE Extrusion Division***

Limited to 100 - you must register to attend.

- ☞ ***Extrusion Basics - Tim Womer, Xaloy***
- ☞ ***Co-Extrusion - Gary Oliver, Cloeren***
- ☞ ***Compounding Extrusion - Paul Anderson, Coperion; Charlie Martin, Leistritz***
- ☞ ***Reactive Extrusion - Paul Anderson, Coperion; Charlie Martin, Leistritz***
- ☞ ***Extrusion Troubleshooting - Mark Spalding, Dow Chemical***

**RENAISSANCE HOTEL - MUSIC CITY BALLROOM**

**9:00 a.m. - 12:00 p.m. – Geiss Workshop**

Limited to 100 - you must register to attend.

- ☞ ***“The Future of the Thermoforming Industry” - Manfred Geiss & Albert Woltron, Geiss USA***

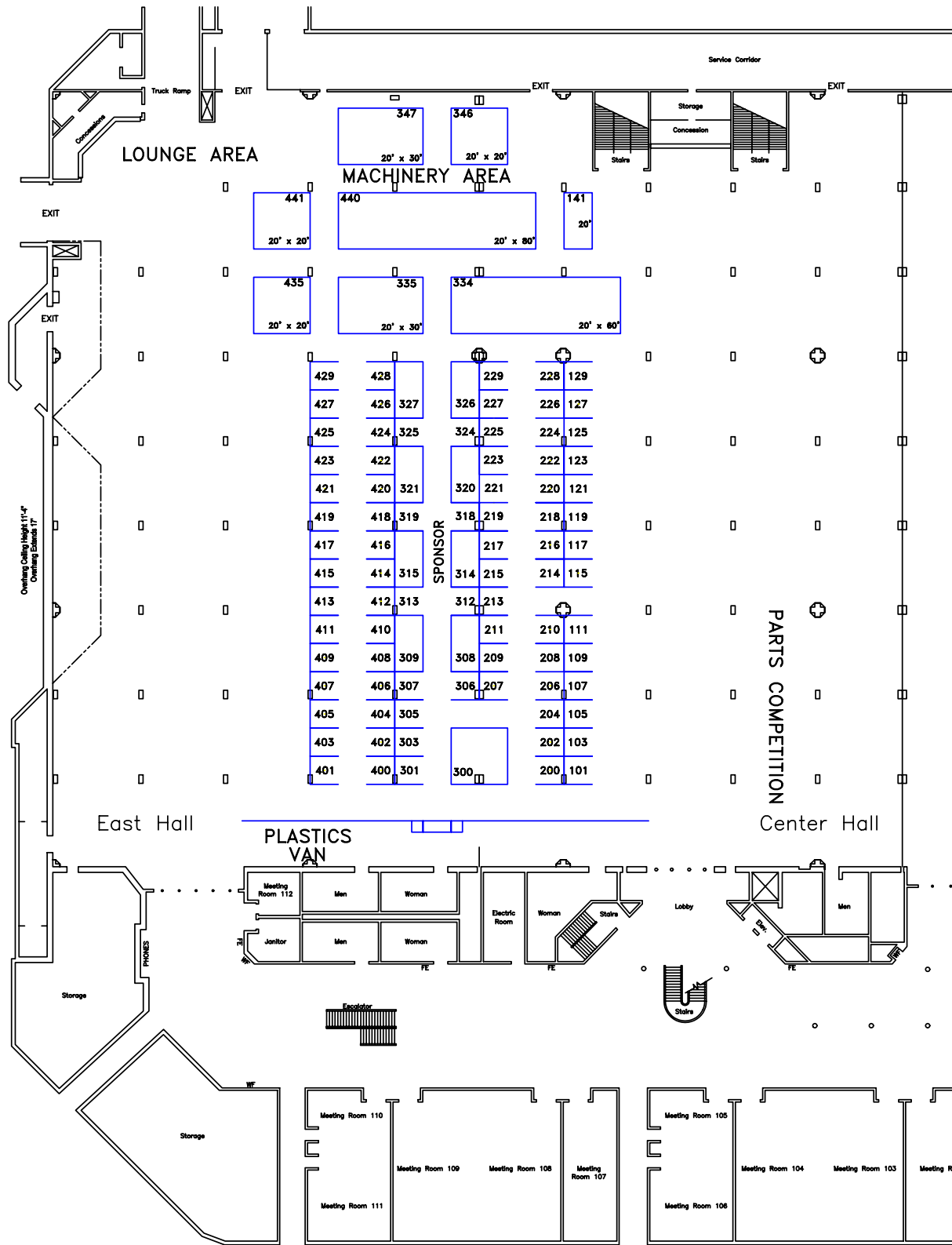

LEVEL ONE

**SPE THERMOFORMING 2006**

NASHVILLE CONVENTION CENTER  
 2006  
 REVISED 1-15-06  
 REV 12

BOOTHS ARE 10' x 10' UNLESS NOTED  
 AISLES ARE 10'



# 16th Annual Parts Competition and Showcase

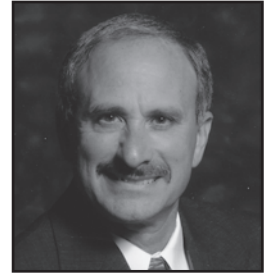

BY JAMES ALONGI, PARTS COMPETITION CHAIRMAN

**W**e invite you to participate in this year's Thermoforming Parts Competition and Showcase. This important event is a part of our 2006 SPE Thermoforming Conference in Nashville, Tennessee, September 17th - 20th, 2006. In order to make this year's Parts Competition and Showcase the best ever, we need your support. Take advantage of this unique opportunity to support your industry, get in front of editors from major publications, and show off your thermoforming skills.

## SHOWCASE OF PARTS

The Showcase of Parts was developed as a non-competitive forum to display products from our industry. This year's showcase will feature past award winning parts, as well as parts not involved in the competition. We also encourage any thermoformer, machinery manufacturer, material supplier, and attendee to share parts with us. This will be a show and tell area for all to promote their parts. Items of interest in the industry like thermoforming versus other processes, new materials, or environmental issues are encouraged. Do you have a success story to share with us?

## Cut Sheet Parts Competition

The following Categories will be Judged:

- Automotive
- Consumer Products
- Twin Sheet Product
- Multi-Part Assembly
- Electronic Products
- Industrial Application
- Point of Purchase



## Roll-Fed Parts Competition

The following Categories will be Judged:

- Consumer Packaging
- Consumer Housewares
- Critical Barrier
- Consumer Electronics
- Food Container
- Industrial Packaging



## Best International Part

## PEOPLE'S CHOICE AWARD

This award is voted on by the attendees and exhibitors of the SPE Thermoforming Conference. Ballots are provided at the Conference registration and the ballot box is located in the Parts Competition Pavilion. One entry per person. The award is presented at the Parts Competition Awards Dinner on Tuesday, September 19th, 2006.

## JUDGING

The judging will be conducted by a panel of six industry professionals, from both the cut sheet and roll fed industries. The judges will have extensive knowledge of all aspects of the thermoforming process. A minimum of 3 entries per category is required for an award to be presented.

## JUDGING CRITERIA

The judging criteria will include technical mastery, surface finish, distinct quality, market viability (compared to other processes), originality, material difficulty, mold complexity, and secondary operations. All entries will remain anonymous until the judging is completed. A part and process write up will be allowed for the judging if it does not include the name of the thermoformer. The parts will be judged based on the process and not the end use of the products.

## AWARDS

All participants and award winners will be recognized on Tuesday, September 19th, 2006 at the Parts Competition Awards Dinner at the Renaissance Hotel.

*For more information, contact: James Alongi  
(630) 665-1700 Fax (630) 665-7999*

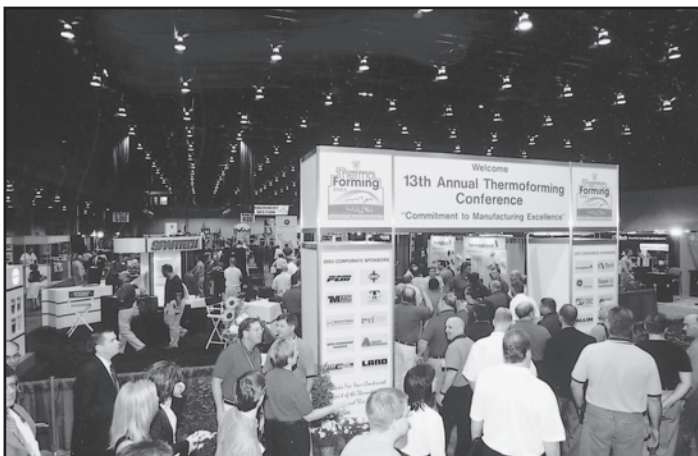

OFFICIAL ENTRY FORM

**16th Annual**  
*Parts Competition and Showcase*

Parts Competition

Showcase Entry

Company: \_\_\_\_\_

Address: \_\_\_\_\_

City: \_\_\_\_\_ State: \_\_\_\_\_ Zip: \_\_\_\_\_ Country: \_\_\_\_\_

Company Contact: \_\_\_\_\_

Telephone: \_\_\_\_\_ Fax: \_\_\_\_\_

E-mail: \_\_\_\_\_

***Entry Specifications:***

Category:  Cut Sheet

Roll Fed

Parts Description: \_\_\_\_\_

Material Type: \_\_\_\_\_ Gauge: \_\_\_\_\_ Supplier: \_\_\_\_\_

Mold Construction: \_\_\_\_\_ Mold Builder: \_\_\_\_\_

Part Description and Unique Challenges for Consideration: \_\_\_\_\_

\_\_\_\_\_

\_\_\_\_\_

***FOR SHIPMENT UP TO 30 DAYS IN ADVANCE OF SHOW:***

Please ship to: Roadway Express  
c/o RPM / Complete Expo Parts Competition  
3240 Franklin-Limestone Road  
Antioch, Tennessee 37013

- Please supply this form with a company labeled photo with each part entry.
  - A supplemental sheet can be provided to expand the part description/unique challenges section. Please refrain from mentioning the company name in this section.
  - A faxed copy of your entry is required by August 21st, 2006 to Fax: (630) 665-7799.
  - **CLEARLY LABEL EACH CARTON: SPE PARTS COMPETITION – DO NOT OPEN!**
  - Parts will be accepted from August 21st to September 11th, 2006.
  - Judging will be done prior to opening of show – entries must be received prior to September 11th, 2006.
- IF YOU DESIRE TO HAVE YOUR PARTS RETURNED, YOU MUST PROVIDE PACKAGING AND ENCLOSE A PRE-ADDRESSED RETURN LABEL AND PREPAID SHIPPING INSTRUCTIONS.**

Signature: \_\_\_\_\_ Date: \_\_\_\_\_

***For more information, please contact James Alongi, Maac Machinery, (630) 665-1700, Fax (630) 665-7799, or email: [jalongi@maacmachinery.com](mailto:jalongi@maacmachinery.com).***

# 16th Annual Thermoforming Conference

Nashville 2006



**"Creativity & Innovation  
in Thermoforming"**

September 17th – 20th, 2006  
Nashville Convention Center  
Renaissance Nashville Hotel  
Nashville, Tennessee



RENAISSANCE.  
NASHVILLE HOTEL

**For Reservations: Call 615.255.8400**  
**Request: SPE Thermoforming Rate**  
**of \$143.00**

*\*\*Please note! The hotel will require a deposit of one night's room and tax at the time the reservation is made. Cancellations made after August 13, 2006 will result in the forfeiture of one night's deposit. Any reservation made after August 13, 2006 will require a non-refundable one night's deposit at the time the reservation is made.*

**Check out our websites at:**

**<http://www.4spe.org/communities/divisions/d25.php>**  
**[www.thermoformingdivision.com](http://www.thermoformingdivision.com)**

**For Information Contact:**

**CONFERENCE COORDINATOR:**

**GWEN MATHIS**

**706.235.9298 • Fax 706.295.4276**

**E-mail: [gmathis224@aol.com](mailto:gmathis224@aol.com)**



# Contents

# Thermoforming<sup>®</sup> QUARTERLY

## TECHNICAL SECTION

### Lead Technical Article:

*Novel Method For Rapid Determination of Thermoformability*..... 10

### Industry Practice:

*Heating Filled Plastics* ..... 16

### University News:

*Rose-Hulman Institute of Technology* ..... 19

### Industry Practice:

*History of Thermoforming – Part III*..... 21

### Thermoforming 101:

*Draft Angles*..... 23

### Book Review:

*Measuring to Manage: Using Measurable Data to Get Maximum Employee Performance* ..... 24

## DIVISION ACTIVITIES

Chairman's Corner ..... Inside Front Cover

Membership Memo: 10 Years – A Good Time to Reflect ..... 2

New Members ..... 3

Spotlight on Industry: Placon Corp. .... 8

Spring Board Meeting Schedule ..... 9

2006 Thermoforming Conference Registration Form ..... 26

Thermoforming Quarterly Index ..... 30

Membership Application ..... 37

Index of Sponsors ..... 40

Board of Directors List ..... Inside Back Cover

These sponsors enable us to publish **Thermoforming Quarterly**



**THE NEW MAAC!**

- \*Larger Mainframes
- \*All Encoder Positioning
- \*Bigger Motors
- \*Adjustable Clampframes
- \*Faster Drives
- \*Guaranteed Cycle Times

Leader in Twin-Sheet Pressure Forming Technology!

- Single Stations
- Double Enders
- Three-Station Rotaries
- Four-Station Rotaries
- Oven-Over
- Custom Machines



4-Week Deliveries!

**WWW.MAACMACHINERY.COM**  
590 Tower Blvd, Carol Stream, IL 60188, Tel: (630) 665-1700

## A NOTE TO PROSPECTIVE AUTHORS

TFQ is an "equal opportunity" publisher! You will note that we have several categories of technical articles, ranging from the super-high tech (sometimes with equations!), to industry practice articles, to book reviews, how to articles, tutorial articles, and so on. Got an article that doesn't seem to fit in these categories? Send it to Jim Throne, Technical Editor, anyway. He'll fit it in! He promises. [By the way, if you are submitting an article, Jim would appreciate it on CD-ROM in DOC format. All graphs and photos should be black and white and of sufficient size and contrast to be scannable. Thanks.]

## Thermoforming<sup>®</sup> QUARTERLY

A JOURNAL PUBLISHED EACH CALENDAR QUARTER BY THE THERMOFORMING DIVISION OF THE SOCIETY OF PLASTICS ENGINEERS

**Editor**  
**Gwen Mathis**  
(706) 235-9298 • Fax (706) 295-4276  
gmathis224@aol.com

**Technical Editor**  
**Dr. James Throne**  
Sherwood Technologies, Inc.  
1797 Santa Barbara Drive  
Dunedin, FL 34698-3347  
1-800-273-6370 • Fax (727) 734-5081  
throne@foamandform.com  
jthrone@tampabay.rr.com

**Sponsorships**  
**Laura Pichon**  
(815) 678-2131 Ext. 624  
Fax (815) 678-4248  
lpichon@extechplastics.com

Thermoforming Quarterly® is published four times annually as an informational and educational bulletin to the members of the Society of Plastics Engineers, Thermoforming Division, and the thermoforming industry. The name, "Thermoforming Quarterly®" and its logotype, are registered trademarks of the Thermoforming Division of the Society of Plastics Engineers, Inc. No part of this publication may be reproduced in any form or by any means without prior written permission of the publisher, copyright holder. Opinions of the authors are their own, and the publishers cannot be held responsible for opinions or representations of any unsolicited material. Printed in the U.S.A.

Thermoforming Quarterly® is registered in the US Patent and Trademark Office (Registration no. 2,229,747).

# *10 Years – A Good Time to Reflect*



**BY MIKE SIROTNAK, MEMBERSHIP CHAIRMAN**

I cannot believe that I have been a member of the SPE Thermoforming Division for 10 years and your Membership Chairman for 8 years. We have been through quite a bit in those years. We have had some amazing highs – Chicago in 1999 – and some unfortunate lows – Milwaukee in 2001. We have had some outstanding growth in both our Conference attendance and in the quality of our *Quarterly*. We are offering more scholarship and committing to more good deeds.

Our industry seems to be really taking off with advancements in automotive, medical packaging and consumer goods. The future of the Thermoforming Industry continues to look bright. The only way to keep up with this fast-moving industry is to continue to support this Division.

The New Year will bring some interesting challenges for all of us. Our Conference will be held September 17th - 20th in Nashville, Tennessee. I think Nashville is my favorite location for our Conference. It has everything

If you have any suggestions on how to improve, grow or challenge this Conference, please feel free to contact one of us on the Board. The amount of “good works” we are able to accomplish due to a successful Conference is

hard to believe. Please continue to support us, so that we may continue to support and grow our industry.

As always, I ask each and every one of you to continue to support membership. If you know of anyone who may benefit

from this *Quarterly* or from any of the other advantages that membership offers, please let us know. Have a great year and I hope to see you in Nashville.

God bless America!!



## **MEMBERSHIP REPORT** *as of 1/4/06*

Primary Paid .....	1,144
Secondary Paid .....	496
Total Membership .....	1,640
Goal as of 6/30/2007 .....	2,000

you need, good food, great music and plenty to see, right within walking distance. Martin Stephenson is working long hours to bring us a great Conference this year. The technical program is in the capable hands of Mike Lowery. I urge all of you to do anything you can to support this Conference.



## To Our New Members

Roger E. Blanton  
Springfield,  
Missouri

Thomas E. Brown  
Allen Extruders,  
Inc.

Ron Connell  
Alcoa Reynolds  
Food  
Packaging

Phillip Crosbie  
Marplex  
Victoria, Australia

Matthias H.  
Erhardt  
Siemens Energy  
& Automation  
Norcross, Georgia

Brian K. Evenson  
Plastica Plus, Inc.  
Brainard,  
Minnesota

Eric Faucher  
Marquex  
Transtech  
Montreal, QC -  
Canada

Ke Feng  
GE Plastics  
Washington, West  
Virginia

Joe Green  
ManPlas, Ltd.  
Stockport, United  
Kingdom

Jeff Griffin  
Eviro Systems,  
Inc.  
Seminole,  
Oklahoma

Seref Halulu  
Saykap As  
Iktell, Turkey

Howard J. Kenney  
Spartech Plastics  
Clayton, Missouri

Youngseok Seiook  
Kim  
Mississauga,  
Ontario -  
Canada

Edward Kus  
Intermatic, Inc.  
Spring Grove,  
Illinois

Niall Marshall  
Kamtion Gate  
South Africa

Steven L. Masia  
SAPPI Fine Paper  
Westbrook, Maine

Jason N. Mattia  
Alcoa Kama  
Hazleton,  
Pennsylvania

Atul Mehta  
New Berlin,  
Wisconsin

Stephanie  
Morgan Fisher  
Stanelco, Inc.  
Orlando, Florida

Richard Motill  
Proex, Inc.  
Batavia, Illinois

Paul J. Nicholson  
Signum NZ Ltd.  
Greenmount,  
New Zealand

Thomas S.  
Pedersen  
Rexam Plastics  
Containers  
Skanderborg,  
Denmark

Mark Rath  
Reynolds Food  
Packaging  
Grove City,  
Pennsylvania

Doug Shelton  
McConkay  
Company  
Summer,  
Washington

Benjamin W.  
Smith  
Devon,  
Pennsylvania

Paul W. Tomich  
First Choice  
Packaging  
Fremont, Ohio

Bill Trometer  
Asheville  
Thermoform  
Plastics  
Fletcher, North  
Carolina

Frank Tucker  
Als Garden Art  
Pty Ltd.  
Gold Coast,  
Australia

David Vadney  
Pactiv  
Canandaigua,  
New York

## WHY JOIN?

*It has never been more important to be a member of your professional society than now, in the current climate of change and volatility in the plastics industry. Now, more than ever, the information you access and the personal networks you create can and will directly impact your future and your career.*

### **Active membership in SPE:**

- **keeps you current**
- **keeps you informed**
- **keeps you connected**

*The question really isn't "why join?" but ...*

## WHY NOT?

# 2005 THERMOFORMING PARTS COMPETITION WINNERS

## RETRACTION

*We sincerely apologize to Perfecseal, Prent Corporation and Profile Plastics for errors in the Parts Competition Section that were published in the 4th Quarter Thermoforming Quarterly. We regret our mistakes and wish to issue the correct information. ~ Editor*

### Critical Barrier Package Award

The redesign of packaging for two medical devices, a sling system and a subfascial hammock, was initiated in order to reduce the size of the packaging and to make it possible to denest the trays without the occurrence of tissue interleaving. By rearranging the orientation of the devices, Perfecseal was able to achieve tray-volume reductions of 68% for the sling system and 54% for the subfascial hammock. Additionally, by using C0025 Internal Denest PETG supplied by Pacur, Inc., Perfecseal was able to eliminate the problem of tissue interleaving without requiring a revalidation of the seal parameters, which would have been necessary if a silicone-coated material had been chosen instead.

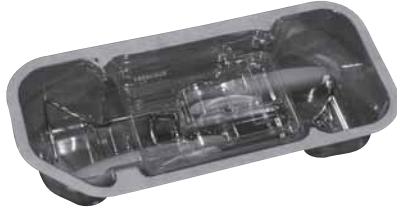

**Perfecseal (A. Demis Co.); 920.303.7129  
www.perfecseal.com**

### Consumer Electronics Award

The packaging for Western Digital's Portable USB Drive is a unique set of four thermoforms, each with a specific role to play in creating the package. Two static dissipative inner thermoforms snap together to secure the hard drive inside trays that are sealed together using radio frequency (RF). The inner parts are made from 0.020-inch clear Pentastat ASKPET 56 supplied by Klockner Pentaplast of America, Inc., and the trays are made from 0.030-inch clear GAG supplied by Thai Kodama Co. Ltd. ASKPET 56 offers ESD protection for the actual product, and the use of GAG provides the ability to RF seal. This 100% recyclable plastic design meets product-protection requirements while providing product visibility, ESD protection, and shelf appeal. The packages, which afford both front and back views of the product, require less shipping space because they interlock when every other one



is rotated 180° in the shipping carton.

**Prent Corporation; 608.754.0276; www.prent.com**

### Roll Fed Competition

#### Most Unique Package Award

The DePuy Orthopaedics Tempfix External Fixation System package consists of five individual thermoformed parts. Each of three modular inner trays carries one of four different fixation devices, along with the tools for their application. One universal cover snap-fits onto each of the modular inner trays, while one universal outer tray holds and protects any of the inner/cover combinations. Each product tray with cover is loaded into the sealable outer tray for sterilization. The cover provides an area for a graphic feature. All inner trays and cover are formed from .040 Blue Tint PETG. The outer tray is formed from .045 Blue Tint PETG Goex Corp. supplies the materials.

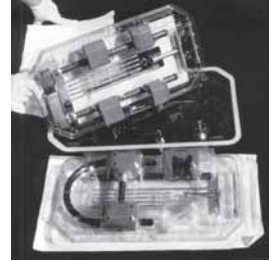

**Prent Corp., 608.754.0276; www.prent.com**

#### Multipart Award

The panoramic analog dental X-ray enclosure required a total of nine parts (12 parts for the digital model), all of which were pressure formed into machined aluminum water-cooled, textured molds. The texturing of molds allows for a consistent part finish for all parts and eliminates evidence of sink marks, knit lines, and gate marks that are typically associated with injection molding. Clean part-to-part fit is accomplished with undercuts in the molds, which are pneumatically articulated with solenoids tied into the digital programming logic of the forming machines. Because of the elliptical contours of the enclosure's design, the undercuts are broken into multiple sections for each side of the parts. Tight process control of molded-in color and texture for consistent part-to-part appearance was required. The material used was 0.187 to 0.375 gauge Kydex T, supplied by Kleerdex Co.



**Profile Plastics; 847.604.5100; www.thermoform.com**

## Need help with your technical school or college expenses?

If you or someone you know is working towards a career in the plastic industry, let the SPE Thermoforming Division help support those education goals.

*Our mission is to facilitate the advancement of thermoforming technologies through education, application, promotion, and research.* Within this past year alone, our organization has awarded multiple scholarships! Get involved and take advantage of available support from your plastic industry!

Start by completing the application forms at [www.thermoformingdivision.com](http://www.thermoformingdivision.com) or at [www.4spe.com](http://www.4spe.com). The deadline for applications is January 15th, 2007. ■



# Thermo Forming

## Division

These sponsors enable us to publish **THERMOFORMING QUARTERLY**

## PCI PLASTIC CONCEPTS & INNOVATIONS LLC

Guiding Innovations in the Development and Production of Thermoformed Products

**Thermoforming & Extrusion Consultants**  
**Manufacturing Processes Analysis**  
**Product & Design Development**  
**Training & Seminars**

PH:843.971.7833 • Fax: 843.216.6151  
 On the Web at [www.plasticconcepts.com](http://www.plasticconcepts.com)  
 443 Long Point Rd Ste H • Mt. Pleasant • SC • 29464-4569

## MAKA ROUTERS

***First to Build 5 Axis CNC Routers...***

- First* to offer Broad Line of 5 Axis CNC Routers
- First* in Accuracy and Speed
- First* in Service and Spare Parts
- First* in Software, Training and Support

***... and We're Still First***



### *JRM International, Inc.*

5701 Industrial Avenue • Rockford, IL 61111 • Fax: 815-282-9150  
 E-Mail: [jrmsales@jrminternational.com](mailto:jrmsales@jrminternational.com) • [www.jrminternational.com](http://www.jrminternational.com)

**TOLL FREE:**  
800-676-4755



## **T Tooling Technology, LLC**

A TOOLING TECH GROUP COMPANY

100 Enterprise Drive • Ft. Loramie, OH 45845  
 tel: (937) 295-3672 • fax: (937) 295-3677  
 Website: [toolingtechgroup.com](http://toolingtechgroup.com)

- Vacuum forming (twin sheet, single sheet, pressure form)
- Rotational molding
- Blow molding
- Router Fixtures
- Compression molding
- E.P.S. molding
- Deep Hole Gundrilling
- Rubber molding
- Polyurethane molding
- Carpet stamping dies
- Metal stamping dies
- Vinyl forming
- Pulp molding
- Models & patterns
- Check Fixtures

Full in House Design, CNC Machining,  
 Aluminum Foundry, & Fabrication Services

# THERMOFORMER OF THE YEAR

## CRITERIA FOR 2007

Every year The SPE Thermoforming Division selects a individual who has made a outstanding contribution to our industry and awards them the Thermoformer of the Year award.

The award in the past has gone to industry pioneers like Bo Stratton and Sam Shapiro, who were among the first to found thermoforming companies and develop our industry. We have included machine designers and builders Gaylord Brown and Robert Butzko and toolmaker John Greip, individuals who helped develop the equipment and mold ideas we all use today. We have also honored engineers like Lew Blanchard and Stephen Sweig, who developed and patented new methods of thermoforming. Additionally, we have featured educators like Bill McConnell, Jim Throne and Herman R. Osmer, who have both spread the word and were key figures in founding the Thermoforming Division.

We're looking for more individuals like these and we're turning to the Thermoforming community to find them. Requirements would include several of the following:

- Founder or Owner of a Thermoforming Company
- Patents Developed
- Is currently active in or recently retired from the Thermoforming Industry
- Is a Processor – or capable of processing
- Someone who developed new markets for or started a new trend or style of Thermoforming
- Significant contributions to the work of the Thermoforming Division Board of Directors

➤ Has made a significant educational contribution to the Thermoforming Industry.

If you would like to bring someone who meets some or all of these requirements to the attention of the Thermoforming Division, please fill out a nomination form and a one-to two-page biography and forward it to:

Thermoforming Division Awards Committee

% Productive Plastics, Inc.

Hal Gilham

103 West Park Drive

Mt. Laurel, NJ 08045

Tel: 856-778-4300

Fax: 856-234-3310

Email:

[halg@productiveplastics.com](mailto:halg@productiveplastics.com)

***You can also find the form and see all the past winners at [www.thermoformingdivision.com](http://www.thermoformingdivision.com) in the Thermoformer of the Year section.***

***You can submit nominations and bios at any time but please keep in mind our deadline for submissions is no later than December 1st of each year, so nominations received after that time will go forward to the next year.***

These sponsors enable us to publish **THERMOFORMING QUARTERLY**

**STRONGER  
THAN  
EVER**

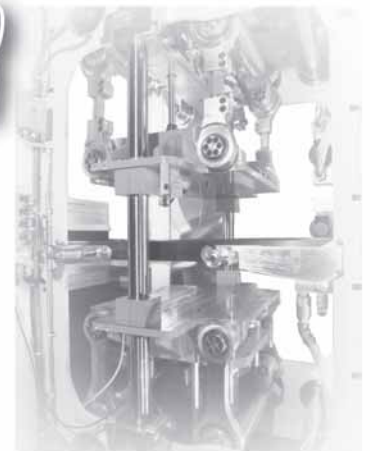

**IRWIN**

Research & Development, Inc.

**THERMOFORMERS | GRINDERS | TOOLING**

**Phone: 509-248-0194 [www.irwinresearch.com](http://www.irwinresearch.com)**

## Thermoformers of the Year ...

1982

William K. McConnell, Jr.  
McConnell Company

1983

E. Bowman Stratton, Jr.  
Auto-Vac Corp.

1984

Gaylord Brown, Brown Machine

1985

Robert L. Butzko,  
Thermrol Corp.

1986

George Wiss,  
Plastofilm Industries

1987

Dr. Herman R. Osmer  
Educator & Consultant

1988

Robert Kittridge  
Fabri-Kal Corporation

1989

Jack Pregont, Prent Corporation

1990

Ripley W. Gage  
Gage Industries

1991

Stanley Rosen  
Mold Systems Corp.

1992

Samuel Shapiro  
Maryland Cup  
Sweetheart Plastics

1993

John Grundy  
Profile Plastics

1994

R. Lewis Blanchard  
Dow Chemical

1995

James L. Blin, Triangle Plastics

1996

John Griep  
Portage Casting & Mold

1997

John S. Hopple, Hopple Plastics

1998

Lyle Shuert, Shuert Industries

1999

Art Buckel, McConnell Company

2000

Dr. James Throne  
Sherwood Technologies

2001

Joseph Pregont, Prent Corp.

2002

Stephen Sweig, Profile Plastics

2003

William Benjamin  
Benjamin Mfg.

2004

Steve Hasselbach, CMI Plastics

2005

Manfred Jacob  
Jacob Kunststofftechnik

# THERMOFORMER OF THE YEAR 2007

*Presented at the September 2007 Thermoforming Conference in Cincinnati, Ohio*

The Awards Committee is now accepting nominations for the 2007 THERMOFORMER OF THE YEAR. Please help us by identifying worthy candidates. This prestigious honor will be awarded to a member of our industry that has made a significant contribution to the Thermoforming Industry in a Technical, Educational, or Management aspect of Thermoforming. Nominees will be evaluated and voted on by the Thermoforming Board of Directors at the Winter 2007 meeting. The deadline for submitting nominations is December 1st, 2006. Please complete the form below and include all biographical information.

Person Nominated: \_\_\_\_\_ Title: \_\_\_\_\_

Firm or Institution: \_\_\_\_\_

Street Address: \_\_\_\_\_ City, State, Zip: \_\_\_\_\_

Telephone: \_\_\_\_\_ Fax: \_\_\_\_\_ E-mail: \_\_\_\_\_

### Biographical Information:

- Nominee's Experience in the Thermoforming Industry.
- Nominee's Education (include degrees, year granted, name and location of university)
- Prior corporate or academic affiliations (include company and/or institutions, title, and approximate dates of affiliations)
- Professional society affiliations
- Professional honors and awards.
- Publications and patents (please attach list).
- Evaluation of the effect of this individual's achievement on technology and progress of the plastics industry. (To support nomination, attach substantial documentation of these achievements.)
- Other significant accomplishments in the field of plastics.
- Professional achievements in plastics (summarize specific achievements upon which this nomination is based on a separate sheet).

Individual Submitting Nomination: \_\_\_\_\_ Title: \_\_\_\_\_

Firm or Institution: \_\_\_\_\_

Address: \_\_\_\_\_ City, State, Zip: \_\_\_\_\_

Phone: \_\_\_\_\_ Fax: \_\_\_\_\_ E-mail: \_\_\_\_\_

Signature: \_\_\_\_\_ Date: \_\_\_\_\_

(ALL NOMINATIONS MUST BE SIGNED)

Please submit all nominations to: Hal Gilham,  
Productive Plastics, 103 West Park Drive  
Mt. Laurel, New Jersey 08045

# PLACON CORPORATION

**P**lacon Corporation, now in its 40<sup>th</sup> year, was the dream and is still the passion of entrepreneur and engineer Tom Mohs.

Headquartered in Madison, Wisconsin, Placon is a global thermoformer, supplying customers on four continents with well-designed, quality manufactured thermoforms. Placon services its global customers from three facilities – Madison, WI; Loves Park, IL; and Suzhou, China.

Company revenues exceeded \$85 million in 2005 through the efforts of nearly 350 team members.

Tom Mohs, who today is the corporation's Chairman, is one of the industry's original entrepreneurs. Tom's keen interest in plastics and plastics processing were evident early on in his life when he led an effort as a student at the UW - Madison's College of Engineering, to convince the Dean to support a plastics processing course in its curriculum and he succeeded.

After graduation, Tom went to work in product development with the Plax Corporation in Connecticut. There, he applied his plastics processing knowledge and design skills to creating new products, particularly thermoformed plastic products. Tom was one of the original developers of the thermoformed high impact polystyrene dairy container and lid.

Always having had an interest in starting his own enterprise,

Tom decided after four years to return to his hometown and start a custom thermoforming business. He had a lot of ideas for new thermoformed products and focused on designing them to efficiently serve their functions. He brought revolutionary ideas to product and tooling design, thermoformer design and processing. He took on the tougher design applications and put forth the effort needed to further the capabilities of the industry.

Today, the company's tagline "Better Design. Better Packaging." ensures the original intent of its founder.

Placon remains privately held by Tom and his family, and stays true to its founder's solid Midwestern values. Tom's greatest desire is that Placon team members can feel proud to work at Placon and, as a result of being part of the organization, can achieve their own personal development and success.

Placon today is a thriving corporation listed in the top 20

in the industry and is driving toward its goal to become a Top 10 North American Thermoformer by 2010. In achieving this goal, the company

believes it will position itself to be able to remain privately-held and continue to determine its own destiny through the next generation.

Placon's primary markets are in food, retail and medical packaging. The company continues to invest in the industry's latest technologies in equipment and operating systems, so that it is capable of continuing to offer its customers what they need to succeed and lead in their markets.

Placon will continue to expand geographically to support its customers' regional needs. Placon opened its first operation in China in December of 2004 to service its retail customer base who, to remain globally competitive, had to move their manufacturing operations to Asia. Outside of Madison and Loves Park, Placon expects to continue its geographic expansion in North America in the upcoming years before 2010.





**THERMOFORMING  
DIVISION  
SPRING BOARD  
MEETING SCHEDULE**

**May 3rd - 7th, 2006**  
**Hilton Oceanfront Resort**  
 23 Ocean Lane  
 Hilton Head, South Carolina  
 www.hiltonoceanfrontresort.com

(Fly into Savannah, Georgia Airport - 40 Minute Drive; Take I-95 N to Exit #8 Hwy. 278 East – take left at Palmetto Dunes – two miles to Hilton Gate)

Roundtrip via Low Country Adventures from Airport – \$24.00

Cab Roundtrip – \$24.00

FOR RESERVATIONS: Call 843-842-8000  
 Request SPE Room Rate of \$189.00

**Wednesday, May 3rd, 2006**

Executive Committee Arrive  
 Technical Chairs Arrive

**Thursday, May 4th, 2006**

7:30 am – 8:00 am – Breakfast  
 8:00 am – 10:00 am – Technical Chairs  
 Meet with Executive Committee  
 10:00 am – 5:00 p.m. – Executive  
 Committee Meeting  
 11:00 am – Noon – James Alongi,  
 Finance Committee Meet with  
 Executive Committee

**Friday, May 5th, 2006**

9:00 am – 11:00 am – Materials  
 Committee - Promenade 1  
 9:00 am – 11:00 am – Machinery  
 Committee - Promenade 8  
 9:00 am – 11:00 am – Processing  
 Committee - Captain's Galley A  
 12:00 pm – 1:00 pm – Lunch - Captain's  
 Galley B  
 1:00 pm – 5:00 pm – All Other  
 Committees - Captain's Galley B  
 6:00 pm – Board Dinner Off Site - TBD

**Saturday, May 6th, 2006**

7:30 am – 8:30 am – Breakfast –  
 Promenade 8  
 8:30 am – Noon – Board of Directors  
 Meeting - Promenade 6-7  
 Golf to be arranged by Joe Peters

**Sunday, May 7th, 2006**

Depart

These sponsors enable us to publish **THERMOFORMING QUARTERLY**

**Ceramic Infrared E-Mitters and Panels**

E-Mitter® **METAMORPHING** Color Change™ provides a visible indication of operation

Stocked in a variety of Standard Colors, Sizes and Electrical Ratings



Curved Face  
(Four  
Standard  
Sizes)



TEMPCO can manufacture custom configured panels to accommodate your process



**KTE Series High Intensity Quartz Mini-Tube Infrared E-Mitters**



Style C  
Ceramic Mounting Heads



Style S  
Mounting Studs

**Universal 2000®  
Tubular Radiant Heater**



**Vitreous Silica Quartz Tube**



Complete Your Thermal Loop System with  
 Tempco's family of **TEC**™ Temperature Controllers

Call today for your free copy of our 864 page  
 Catalog of Electric Heaters, Temperature Controls and Sensors



© 2004 All Rights Reserved.

TEMPCO Electric Heater Corporation  
 607 N. Central Avenue • Wood Dale, IL 60191  
 (630) 350-2252 • Toll Free (800) 323-6859  
 Fax (630) 350-0232 • E-mail: info@tempco.com

Product Inventory available for Viewing and Selection @ [tempco.com](http://tempco.com)

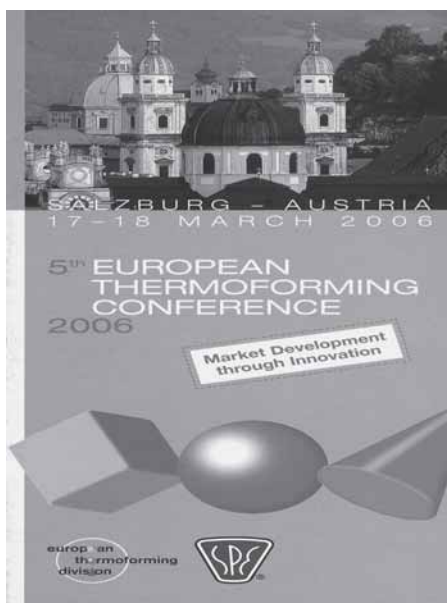

**Visit  
the  
SPE  
website  
at  
[www.4spe.org](http://www.4spe.org)**

# Novel Method For Rapid Determination of Thermoformability<sup>1</sup>

---

BY A. DHARIA, TRANSMIT TECHNOLOGY GROUP, LLC, IRVING, TEXAS and  
D. HYLTON, McCONNELL CO., INC., FAIRBURN, GEORGIA

---

## *Abstract*

The demand for large parts with thick walls, constructed of multiple polymer layers, along with the desire for quick turn-around time, lower tooling cost, and low-pressure processing is making thermoforming very attractive v. injection molding. Despite the long history, thermoforming is still very much an art rather than a science. There are very few reliable tests available to processes and researchers for analyzing and quantifying thermoformability. This paper presents a comparison between current methods and a novel test apparatus that closely simulates the thermoforming process under controllable conditions while collecting quantitative information, which can be used to assess, compare, optimize, or predict thermoformability of given plastic materials.

## *Introduction*

Thermoforming is a widely used process to produce deep arts of various wall thickness and surface textures. Production is very cost-effective with respect to tooling and machine costs and modern machines can achieve high output rates. In principle, thermoforming is a simple process of stretching heating plastic sheet over or into a mold cavity. Theoretically, the ability of a plastic material to be shaped by thermoforming depends on the rate of change of strength or modulus with the change in strain rate and temperature (1). In reality, the process is a complex interplay between polymer molecular weight (MW), molecular weight

distribution (MWD), crystallinity, density, thermal conductivity, and temperature-dependent melt viscosity and melt elasticity. Another variable, which may influence thermoformability, is the processing history of the extruded sheet stock. The larger the part and the thicker the wall become, the more complex is the effect of these factors during and after the forming process. Significant hands-on experience is required to make new polymeric materials work.

Unlike other processes, thermoforming requires flat sheet, not pellets, as feedstock. So any material intended for thermoforming must be first converted into sheet. Depending on the process of making sheet, process conditions, process rates, amount of regrind, and storage conditions, the feedstock may vary in its thermal stress distribution, within and between lots. This can create a real blind spot, which converters overcome by on-line adjustment of the thermoforming process parameters. The situation can be even more complex if the extruded sheet consists of more than one plastic, with dissimilar natures, or with one side of the sheet grained or textured. For most other processes, judicious use of the simple melt flow rate test can help processors solve many of the processing and quality related issues.

This is not the case with thermoforming. Actual determination of thermoformability through field trials can be very expensive. What test will one use to make sure whether or not a new material will thermoform satisfactorily? How does one learn about lot-to-lot or within-lot variations? How does one accommodate known variations? There is no easy-to-use, repeatable, yet comprehensive test to rescue converters, especially when a new material or supplier is involved.

Several tests (2) are available, some of which are very crude, qualitative, easy to understand but not

---

<sup>1</sup> Ed. Note: This article was presented at ANTEC 2005. It has been retyped and edited from the ANTEC Proceedings paper. Any errors, omissions or commissions are solely the responsibility of the Technical Editor.

repeatable. Others are highly analytical, expensive and difficult to comprehend. The following is a review of some of these tests.

**Sag test** (3). Sag is the temperature-dependent measure of tensile strength and sheet geometry. This is the most commonly used test, which simulates hot creep under no external load. A flat sheet is clamped in a frame and heated to a forming temperature inside a forced air oven or by radiant heaters. The time required for the heated sheet to sag to a fixed distance is reported as sag resistance. This test is a useful first step but the results depend on how the sample is clamped (circular window v. rectangular window, cantilever v. all sides clamped), sheet weight, method of heating, surface area, and sheet thickness. It is often not repeatable and does not provide any clue about melt elasticity, i.e., how the heated sheet will react to external stresses in, say, plug-assisted forming. The plastic may have a very high sag resistance but may have no ability to form at all.

**Hot tensile/creep test** (4). As the polymer temperature increases, its strength and modulus decrease and elongation increases. Thermoforming occurs in the rubbery plateau, at temperatures above the glass transition temperature,  $T_g$ . The broader the rubbery plateau and the higher the polymer modulus at the forming temperature, the better the thermoformability. In this test, a specimen is die-cut from the extruded sheet. It is heated to the desired temperature in a forced air environmental chamber and is stretched at constant speed. The tensile modulus or strength is plotted against strain. Even though quantitative in nature, hot tensile tests are difficult to carry out with any degree of reliability. At elevated temperatures, stretching is not confined to the neck-down portion, and grip-slip or grip-extrusion is common. Slow heating rates may induce annealing.

Hot creep tests are more sensitive than hot tensile tests to changes in polymer character. Further, heat is conducted to the load cell, affecting the accuracy.

Neither test truly replicates biaxial stretching under rapid speed ( $>20$  mm/sec), and heat transfer between the mold and the heated plastic sheet that is so common even in the simplest thermoforming process is not present in either test.

**Dynamic rheological tests.** Dynamic mechanical testing is used to determine the storage or elastic

modulus ( $G'$ ) and the loss or viscous modulus ( $G''$ ) as functions of temperature or strain rate. This test requires less material than those given above, can be done rapidly, and the results are highly repeatable. The data provide indirect information about MD and MWD, as well as direct information of the complex modulus as a function of temperature (5). Higher zero shear viscosity, broader MWD, and higher modulus at the forming temperature are considered to be favorable attributes of a polymer. However, the test equipment is expensive and requires a trained person to run the test and interpret the data. Most importantly, it does not reflect the variables in the thermoforming process.

The thermoforming process can be simulated through the stress relaxation experiment (6). In this test, stress is applied to the plastic and the decay in stress relaxation is measured. Stress relaxation time is reported to increase linearly with sag resistance (5). However, at elevated temperatures at high-applied stress levels, the creep rates are very high, making interpretation of the creep data difficult. In addition, the stress relaxation constant varies with the test parameters selected.

**Melt tension test.** In this test, the plastic is melted, extruded into a fiber, and the fiber is stretched at constant velocity. One device that performs this test is the Rheotan attached to a capillary rheometer. The test is repeated at various velocities. The force and velocity at which the fiber breaks are reported as melt strength and draw velocity. Even though this test is useful, it is not very representative of the thermoforming process. First, the process is done above the melt temperature of the polymer, while most thermoforming is done in the rubbery region of the polymer. Thus, all information relating to sheet extrusion parameters are lost during the melting step. Fiber is one-dimensional while thin sheet is two-dimensional and thick sheet is three-dimensional. The draw strength and velocity can vary with the way in which the fiber is cooled. Further, some plastics tend to strengthen by stretching in one dimension. This is a simple test and results are easy to interpret, but the data do not correlate well with the forming process variables.

(continued on next page)

**Numerical methods** (7). There are computational tools which numerically simulate thermoforming and predict response to input variables. However, these methods, like most numerical simulation methods, are based on simplified assumptions, and require values of many polymer characteristics, many of which are not readily available or are expensive to obtain. The free surface flow involved and the complexity of modeling melt elasticity make these models less reliable.

In absence of any real, easy-to-use and easy-to-interpret test method, one must resort to actual thermoforming. This may require a large amount of plastic sheet, time, and money. Results of one trial may not always be applicable to actual production. Therefore, we propose a method that overcomes many of these obstacles.

## Proposed Equipment

As shown in Figure 1, the proposed automated equipment is a miniature version of actual thermoforming machine and incorporates all essential unit steps – heating, forming, and cooling. It uses 4-inch x 4-inch square sample of desired

rate, heat soak time, ram speed, cooling time, maximum force, and the maximum draw depth. Once activated, the sample tray moves to the heating station where two infrared or ceramic heaters heat the sample from above and below. Both heaters can be programmed independently and can be positioned at desired distances from the sample surfaces. A non-contact, laser-guided infrared temperature probe continuously measures the surface temperature.

When the sheet reaches the preset surface temperature, or the preset temperature and heat soak time, the tray moves to the forming station in less than a second. A plunger, equipped with a male plug descends into the sheet at a preprogrammed speed. The force required to deform the heated sheet is continuously measured by a load cell mounted on the top of the plug. The computer interface captures the force data and plots it as a function of either the distance from the surface or time.

As soon as either the preset force is reached or the sheet is deformed to a preprogrammed distance, a fan is activated to cool the sample for a preprogrammed time. At the end of the cooling time, the plunger retracts and the tray carrying the cold, formed part is returned to the loading station. The part is then manually removed from the tray, inspected for wall thinning, tearing, blisters, burn marks, loss of grain or texture, loss of gloss, fading, and so on. Thickness is manually measured and the thickness distribution recorded.

The equipment and software allow selection of pressure forming, vacuum forming, or vacuum-assisted pressure forming.

The force data can either be used as is or with suitable software, can be converted into a predictive model.

The equipment overcomes several problems of earlier methods:

- It uses a small amount of sample, either from existing feedstock or made using available quality control equipment.
- It heats material rapidly but under controllable conditions. This allows mimicking actual thermoforming conditions. Further, the top and bottom of the sheet can be heated to different temperatures either by adjusting the distance

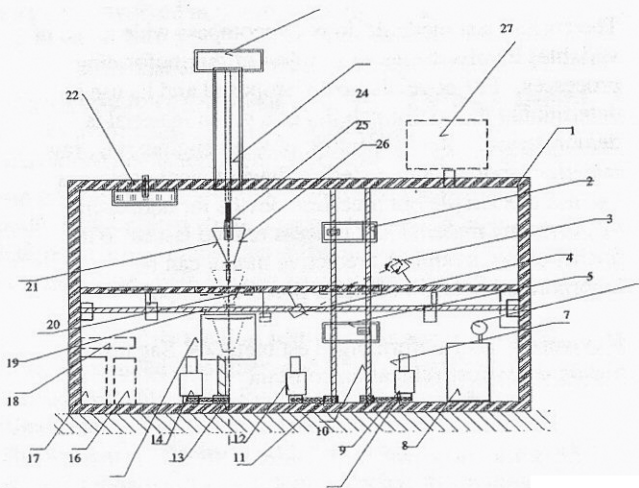

Figure 1. Thermoformability Analyzer<sup>®</sup>.

thickness, preferably die-cut from extruded feedstock, but it can also be injection or compression molded. Most quality control labs have 8-inch x 8-inch heated compression presses and injection molding machines. The sample is clamped between two insulated plates, and the tray is manually placed on the loading rail.

A software input menu includes the selection of the forming method, forming temperature, heating

of the heaters to the sheet or by adjusting the heating rates. This is helpful when coextruded sheets are used.

- The force is measured using an accurate load cell while the sample is losing heat, as is typical of the actual thermoforming process.
- The ability to change forming speed can be useful in studying the effect of increased line speed.
- The unit allows changes in plug geometry and type of plug material, simulating the effect of plug materials.
- Once the part is formed, it is cooled under controlled conditions to determine the effect of cooling on shrinkage, warpage, grain distortion, gloss variation, and so on. These observations cannot be made in any of the aforementioned methods.
- The equipment is as easy to use as the melt flow indexer and it provides quantitative data under controlled conditions, which can be repeated.

### Test Results

Extruded sheets of nylon, HDPE, ABS, PP, PC, PVC, PMMA, POM, HIPS, PETG, filled TPO, and HMS-TPO were obtained from suppliers. Samples were cut from various feedstocks and thermoformed using a 100 mm long, 50 mm diameter, 30-degree truncated cone plug under various plug speeds and sheet temperatures.

Figure 2 shows the relationship between the forming force and depth of draw at 150°C for several polymers. The required force increases with increase in melt strength. Polymers with true strain hardening show an increase in the force required with increasing draw depth, as seen for POM in Figure 3. For crystalline polymers, an increase in force at the deepest draws is due to the cooling of the sheet as it contacts the cold plug. The sag distance can be estimated from the depth of penetration of the plug before the transducer measures a non-zero force.

Figure 4 shows the effect of sheet temperature on the force required to form various polymers to a draw depth of 100 mm at 20 mm/second using the truncated cone plug. As seen for most

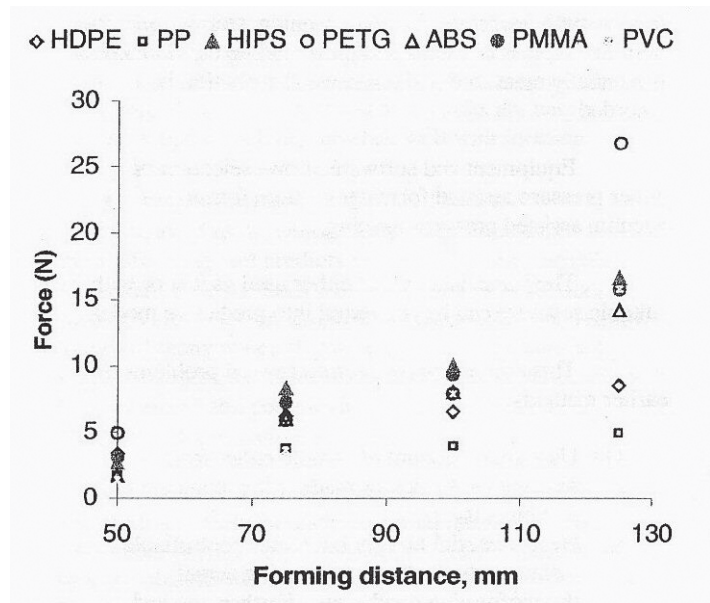

Figure 2. Forming force vs. draw depth at 150 C (truncated cone plug mold at 20 mm/second speed).

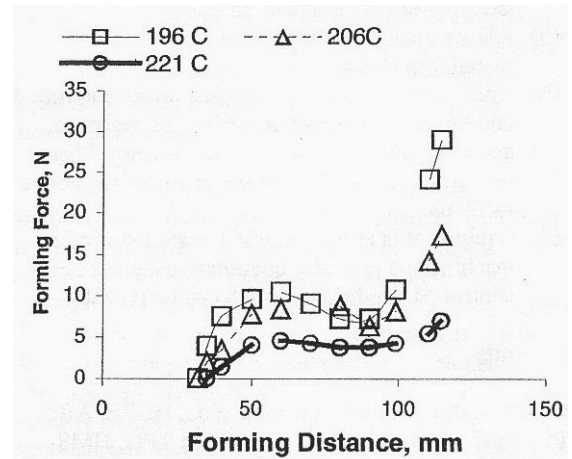

Figure 3. Effect of cooling on force for Acetal (Cup mold, 20 mm/second).

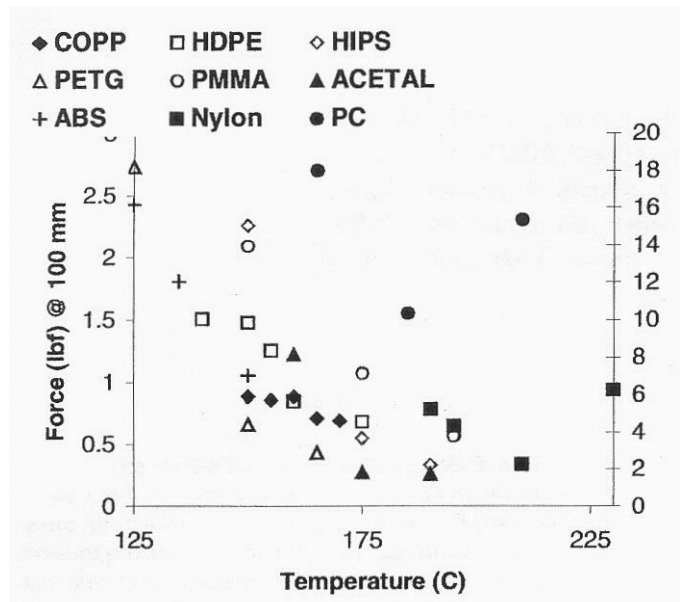

Figure 4. Relationship between forming temperature and force (truncated cone plug at 20 mm/second speed).

(continued on next page)

(continued from previous page)

amorphous materials such as ABS, HIPS, PMMA, PVC and PETG, the force decreases nearly linearly with sheet temperature. For crystalline polymers, the force does not decrease linearly. For HDPE and PP, a step change in the force occurs around the polymer melt temperature. For nylon and PC, the force actually increases around their melt temperatures.<sup>2</sup>

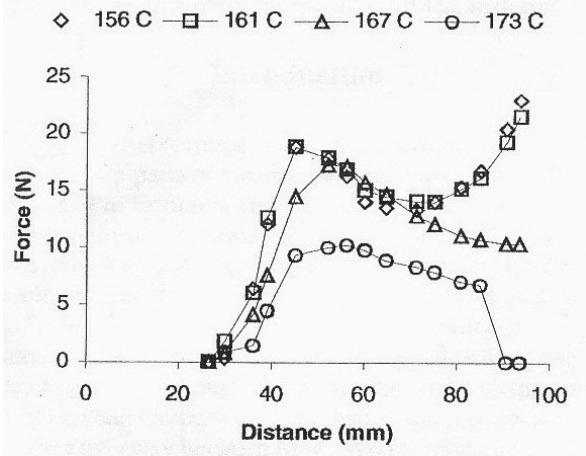

Figure 5a. HMS-TPO, effect of temperature at 20 mm/second, cup shape plug.

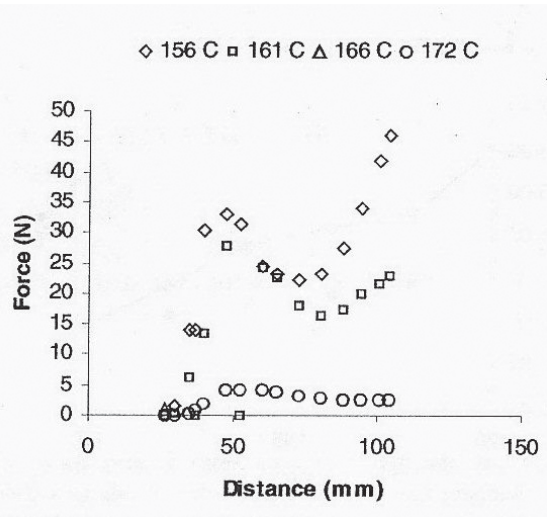

Figure 5b. Effect of temperature, filled TPO.

Figures 5a and 5b show the effect of temperature on the forming characteristics of talc-filled TPO and HMS-TPO. The TPOs have similar tensile strengths and moduli at room temperature. HMS-TPO does not show a loss in melt strength while the filled TPO does. Figure 5c shows the effect of test speed on the forming characteristics of these two polyolefins. At high speeds, the filled TPO shows

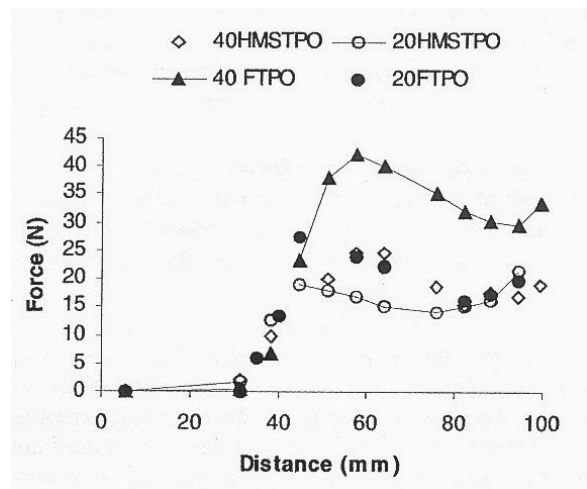

Figure 5c. Effect of forming speed.

substantial loss in melt strength whereas the HMS-TPO shows very little change in the same temperature range. The increase in stress at greater deformation indicates a strain-hardening effect.

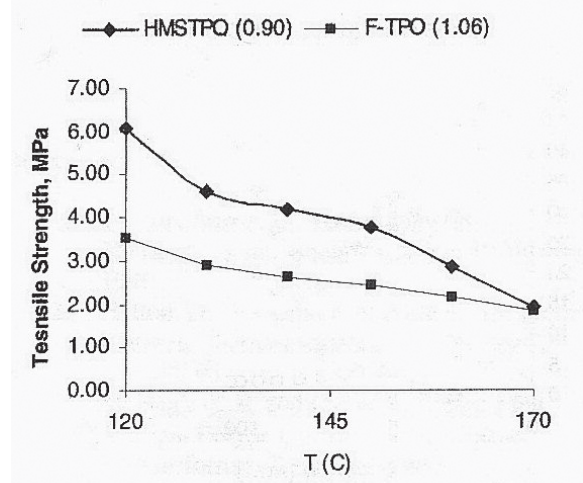

Figure 6. Tensile yield stress vs. temperature.

Figure 6 shows the tensile strength v. temperature for these two TPOs, measured at a 50-mm/min crosshead speed. The HMS-TPO has a much higher tensile strength than that for the filled TPO.

## Conclusions

The current test methods reviewed above do not encompass the wide range of variables found in even the simplest of thermoforming processes. The proposed novel device has demonstrated its use in determining the thermoformability of many polymer materials. Quality control, process engineering, raw material suppliers, and materials development engineers can use this simple but precise device for addressing thermoforming material- and process-related issues. With further

<sup>2</sup> Ed. Note: Commercially available PC is normally an amorphous polymer with a glass transition temperature of around 150°C.

effort, a built-in predictive model can be incorporated to allow efficient process set-ups. ■

## References

1. J. L. Throne, **Technology of Thermoforming**, Hanser/Gardner Publications, Cincinnati, 1996.
2. D. Hylton, "Laboratory techniques for predicting material thermoformability," ANTEC 1991.
3. K. E. McHugh and K. Ogale, "High melt strength polypropylene for melt phase thermoforming," ANTEC 1990.
4. N. McCauley, E. Harkin-Jones, and W. R. Murphy, "Thermoforming of polypropylene," *Plastics Engineering*, July 1996.
5. V. E. Malpass and C. H. White, *SPE Journal*, Nov., 1971, Vol. 27.
6. G. R. Ziegchner and P. D. Patel, "Comprehensive evaluation of PP melt rheology," 2<sup>nd</sup> World Conference on Chemical Engineering, Montreal, October 1981.
7. B. Hagemann and P. Eyerer, "Improving industry through technical development."
8. D. Hylton and C. Tameka, "Rheological studies of commercial thermoforming materials," ANTEC 1988.
9. A. Dharia, U. S. Patent Application 10/920,127.

These sponsors enable us to publish **THERMOFORMING QUARTERLY**

# Plastics for the Thermoforming Industry



LANXESS

Energizing Chemistry

Lustran® ABS  
Lustran® SAN  
Lustran® Soft Touch  
Centrex® ASA/AES  
Centrex® Soft Touch

For information call  
**1-800-LANXESS**  
[www.US.LANXESS.com](http://www.US.LANXESS.com)

# PROTHERM

Industry-leading process heating capabilities for just about every industry that needs to finish a product!

From simple heater arrays to complete conveyorized ovens, **PROTHERM™** completes your project from product analysis, testing, design, to final build.

Whether you're finishing textiles, converting film or foils, thermoforming plastics, or powder coating fenders, you can rely on **PROTHERM™** for complete design, installation and start-up support.

Contact a **PROTHERM™ Applications Specialist** for assistance at **1-800-793-2077**.

For more information...  
Visit our web site at **www.pro-therm.com**



Series FSA, 40, and INFRAROUND infrared heaters for OEM and product manufacturing

Web Dryer for textiles & material converting applications

Thermo Plastic Annealing Oven



www.wecoproducts.com

Quartz Tungsten

Quartz Halogen

FastIR System

Offering the finest in INFRARED Process Heating Products!



Full Oven Platens

Let us offer expert professional assistance for all your Infrared needs...From Ceramic Elements to Full Oven Systems...WE CAN HELP Quartz, Quartz Tungsten, Halogen all from STOCK! Fully assembled Reflectors to ease oven construction....Panel Heaters and Full Oven Platens constructed to your Specifications

901 Tacoma Court Clio, Michigan 48420

810-686-7221 fax 810-686-7564



Ceramicx  
Ireland Ltd

# Heating Filled Plastics

BY JIM THRONE, SHERWOOD TECHNOLOGIES, INC., DUNEDIN, FL

**W**e've all heard the argument that filled plastics heat at different rates than unfilled plastics. This Industry Practice article explores this argument with simple examples. The theoretical analysis will appear in a subsequent Technical Article in TFQ.

We need to make some simplifying assumptions. Consider our filler to be TiO<sub>2</sub>, either an opacifier at a relatively low loading of 10 wt% (Example A) or a filler at relatively high loading of 40 wt% (Example B). For simplicity, consider the particle shape to be spherical with a particle size of 10 microns. Consider the plastic to be generic. We'll need to make additional assumptions later.

Some simple arithmetic, first.

**Volume Fraction:** The filler volume fraction is given in terms of weight fraction as:

$$\text{Volfrac} = \text{wtfrac} (\text{density}_{\text{polymer}} / \text{density}_{\text{filler}})$$

The density of TiO<sub>2</sub> = 4.36. The density of our generic plastic is 1.0, say. The volume fractions of our two loadings are:

Example A:  $\text{Volfrac} = 0.10 (1/4.36) = 0.0235$  or 2.35 vol%

Example B:  $\text{Volfrac} = 0.40 (1/4.36) = 0.0917$  or 9.17%

**Plastic-filled Density:** The density of a filled plastic is given as:

$$1/r_{\text{filled}} = \text{wtfrac}/r_{\text{filler}} + (1-\text{wtfrac})/r_{\text{plastic}}$$

Example A:  $r_{\text{filled}} = 1/[0.10/4.36 + 0.9/1] = 1.08$

Example B:  $r_{\text{filled}} = 1/[0.40/4.36 + 0.6/1] = 1.45$

**Specific Heat:** The specific heat or heat capacity is a measure of the amount of heat required to heat the plastic to its forming temperature. The greater the specific heat, the more energy is required.

$$\text{SpHt}_{\text{filled}} = \text{Volfrac} \times \text{SpHt}_{\text{filler}} + (1-\text{Volfrac}) \times \text{SpHt}_{\text{plastic}}$$

The specific heat of TiO<sub>2</sub> is 0.2. The specific heat of neat generic plastic is, say, 0.4.

Example A:  $\text{SpHt}_{\text{filled}} = 0.0235 \times 0.2 + (1-0.0235) \times 0.4 = 0.394$

Example B:  $\text{SpHt}_{\text{filled}} = 0.0917 \times 0.2 + (1-0.0917) \times 0.4 = 0.382$

**Thermal Conductivity:** The equation for thermal conductivity of a filled plastic is relatively complex. It is the Nielsen equation, used to determine, among other things, the mechanical properties of composite systems.

$$k_{\text{filled}}/k_{\text{plastic}} = (1+AB\text{Volfrac})/(1-BQ\text{Volfrac})$$

$$B = (k_{\text{filler}}/k_{\text{plastic}} - 1)/(k_{\text{filler}}/k_{\text{plastic}} + A)$$

$$Q = 1 + [(1-\text{Volfrac}_{\text{max}})/\text{Volfrac}_{\text{max}}^2]v$$

$$A = \text{kappa}_E - 1$$

$$\text{Volfrac}_{\text{max}} = 0.6 \text{ (random spheres)}$$

$$\text{kappa}_E = 2.5 \text{ (spheres)}$$

The most important aspect of this equation is the term, Volfrac<sub>max</sub>. This is the maximum packing that can be achieved with the particular filler. For this case, we assume that we have uniformly dimensioned spheres. As a result, A = 1.5.

Example A:  $Q = 1 + [(1-0.6)/0.62]0.0235 = 1.026$

$$B = (40/0.4 - 1)/(40/0.4 + 1.5) = 0.975$$

$$k_{\text{filled}}/k_{\text{plastic}} = (1 + 1.5 \times 0.975 \times 0.0235) / (1 - 0.975 \times 1.026 \times 0.0235) = 1.059$$

Example B:  $Q = 1 + 1.11 \times 0.0917 = 1.102$

$$B = 0.975$$

$$k_{\text{filled}}/k_{\text{plastic}} = (1 + 1.5 \times 0.975 \times 0.0917) / (1 - 0.975 \times 1.102 \times 0.0917) = 1.258$$

Now we can summarize the changes in thermal properties because of the presence of TiO<sub>2</sub> in the plastic.



## Summary

Filler conc Wt %	Inc in dens	Inc in sp ht	Inc in thermal k	Inc in heat duty
0	1	1	1	0
10	8%	-1.25%	5.9%	6.4%
40	45%	-4.5%	25.8%	38.5%

As expected, increasing filler concentration results in increased filled polymer density. The specific heat does not substantially decrease. Therefore, the total amount of energy required to raise a specific volume of filled plastic to its forming temperature (that is, its specific gravity times its density or its heat duty) increases substantially with increasing filler concentration. In the case of 40 wt% TiO<sub>2</sub>, the additional heat duty is 38.5%.

In short, the more rock there is, the more energy it takes to heat it.

Now we explore another facet of this question: Does the presence of filler change the way in which the plastic receives radiant energy? To answer this question, we need to consider geometry. This time, we consider a cube of plastic, T units on a side. Assume for the moment that the filler is compressed into a cube, t units on a side. What is the volume occupied by the filler?

A simple form of the equation is:

$$A_{\text{filler}} = (t/T)^2 = (\text{Volfrac})^{2/3}$$

Example A:  $A_{\text{filler}} = (0.0235)^{2/3} = 0.082$  or 8.2% of the surface is filler

Example B:  $A_{\text{filler}} = (0.0917)^{2/3} = 0.203$  or 20.3% of the surface is filler<sup>1</sup>

We now need to make some simplifying assumptions about the volumetric distribution of the particles in the plastic matrix. Recall that our particle size is 10 microns. We assume that the particles are uniformly distributed throughout the volume. As a result, the first 10 microns of the filled plastic are composed of about 8% filler for the 10 wt% dosage and about 20% for the 40 wt% dosage. For the rest of this journey, consider only the higher dosage case.

As we know from FTIR graphs, all plastics are semi-transparent to incident far-infrared radiation. Consider the case where the average transmission

<sup>1</sup> This is not quite correct, because we are not properly taking into account the volume occupied by the filler. But, considering all the other assumptions ...

of radiant energy though the first 10 microns of plastic is 50%. This means that 50% of the incident energy is absorbed by the first 10 microns of plastic and 50% is transmitted to the next 10 microns. Furthermore, assume that in the next 10 microns of plastic, 50% of that energy is absorbed and 50% is transmitted to the third 10 microns of plastic. And so on.

As we said, we are using the 40 wt% dosage case. Assume that the filler particles reside in 10 micron layers throughout the plastic. As a result, 20% of the first 10 microns of plastic contain filler particles. As does the next 10 microns and the next 10 microns, and so on. For this analysis, consider that all the incoming radiation that impinges on the filler particles is totally absorbed, to be ultimately conducted into the plastic.

Now consider inbound radiation to the first 10 microns of filled plastic. That portion that impinges on the filler is completely absorbed. That portion that impinges on plastic is only 50% absorbed, as we assumed above. This is written as:

### **1<sup>st</sup> Layer:**

Absorbed: inbound radiation x filler area + absorbed portion x open area =

Transmission: filler block of all radiation x filler area + transmitted portion x open area =

Absorbed: 100% of 20% + 50% of (100%-20%) = 60%

Transmitted: 0% of 20% + 50% of (100%-20%) = 40%

Now for the second layer, only 50% of the original radiation is available. And an additional 20% of the surface area is blocked by filler particles. So this is written as:

### **2<sup>nd</sup> Layer:**

Absorbed: 50% of 20% + 50% of 50% of (80% - 20%) = 25%

*(continued on next page)*

(continued from previous page)

Transmitted: 0% of 20% + 50% of 50% of (80% - 20%) = 15%

On to the third layer. Only 50% of the 50% of the previous radiation is available for absorption and transmission. And an additional 20% of that surface area is blocked. So we write:

**3<sup>rd</sup> Layer:**

Absorbed: 50% of 50% of 20% + 50% of 50% of 50% of (60% - 20%) = 0.10

Transmitted: 0% of 20% + 50% of 50% of 50% of (60% - 20%) = 0.05

And so on. Consider a tabulation of these absorption data, compared with energy uptake of the unfilled plastic:

**Total Layer-by-Layer Absorption**

Filler Conc	1 <sup>st</sup>	2 <sup>nd</sup>	3 <sup>rd</sup>	4 <sup>th</sup>	5 <sup>th</sup>	6 <sup>th</sup>	7 <sup>th</sup>
0	50%	75%	87%	94%	97%	98%	99%
40	60%	85%	95%	99%	100%		

It is apparent that the filler blocks radiation transmission into the polymer. Therefore, all things being equal, the sheet *surface* should heat at a rate that increases with increasing filler concentration. And, because infrared thermometers measure sheet *surface* temperature, filled polymers *appear* to heat faster than unfilled polymers.

But wait. As we saw earlier, the thermal conductivity of the filled plastic increases with increasing filler dosage. This means that even though the surface of a filled plastic receives more energy than that of an unfilled plastic, the energy is conducted into the interior of the plastic at a faster rate.

**Conclusion**

There are two general aspects to energy input to filled plastics. The first is that the energy needed to raise a filled polymer to its forming temperature

increases with increasing filler concentration. The primary reason is that the plastic density increases with increasing filler concentration.

The second is that at the same energy input rate, filled polymer surfaces absorb more energy than unfilled polymer surfaces. If this were the only effect, we would see filled polymer

surfaces heating at a more rapid rate than those of unfilled polymers. And normally we do. However, filled polymers have higher thermal conductivities than unfilled polymers. This means that for filled polymers, the energy near the surface is conducted to the interior at a faster rate than that for unfilled polymers. This is a very important compensating factor. On balance, a polymer heats at about the same rate whether neat or filled. ■

*We need your continued support and your efforts on membership recruitment!!*

These sponsors enable us to publish **THERMOFORMING QUARTERLY**

**KMD Series Machine**  
High Performance Pressure Forming  
for Packaging Parts for a variety of Industries

**KIEFEL**  
The experience to form your future.

**KIEFEL TECHNOLOGIES, INC.**  
7 Scott Road  
Hampton, NH 03842  
Tel: 603-929-3900 • Fax: 603-926-1387  
www.kiefeltech.com  
e-mail kiefel@kiefeltech.com

# Distortion Graphics for Thermoformed Parts – Elastic Image, A Development of Rose-Hulman Institute of Technology

### *Who are we?*

We are graphics and plastics professionals backed by a strong corps of engineers and software scientists. We have developed an automated digital solution for distorting graphics for pre-decorating plastics. We are partnered with Rose-Hulman Ventures (RHV), a technology incubator arm of Rose-Hulman Institute of Technology in Terre Haute, IN. Together we have developed proprietary software and hardware to expand capabilities in the manufacturing of decorated plastic products for a wide variety of applications. Our partnership with RHV allows us to accelerate our technical development through R & D and engineering initiatives. As a result, EI has established the benchmark for exceptional quality in pre-decorated plastics.

### *What are we selling?*

We deliver the ability to advance manufacturing capabilities for decorating formed plastic products. We provide the means for manufacturers to eliminate the risks and design limitations inherent in the outdated trial-and-error methods for distorting graphics. EI provides speed-to-market in both the development and production phases. We drive value at every touch-point in the cycle from design concept to final delivery. Designers, tool makers, plastics companies, graphics producers, and forming manufacturers are embracing the EI technology. We enable clients by providing a unique platform for increased creativity and design flexibility. We develop new products that deliver increased value-added. Our technology offers powerful differentiation opportunities for our customer's products and brands.

### *How was it developed?*

The current technology is a proprietary integrated suite of hardware and software comprised of machine vision-based data collection and graphic distortion computation. It is the result of the marriage of development between two groups of software scientists and engineers. Each group tackled part of the challenge. An RHV group developed the 3D scanning solution that quantifies material stretch while another developed the graphics distortion package. These two platform technologies were brought together initially in 2003. In parallel with commercial rollout, EI has continued to improve both platforms and is now in its fourth phase of development. EI and RHV continue to commit resources against the ongoing development and evolution of the technology.

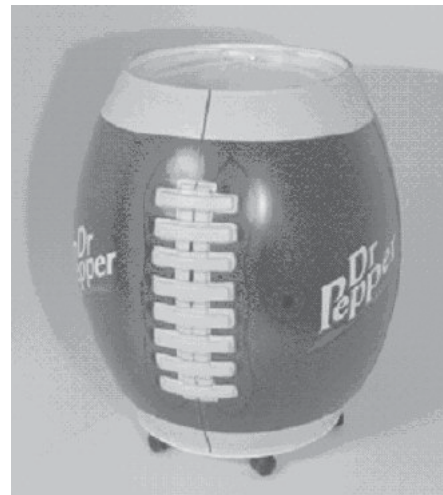

### *How does it work?*

Unlike attempts to develop distortion solutions through predictive means, the EI solution is based on capturing the specific surface dynamics of a

*(continued on next page)*

(continued from previous page)

plastic part during the forming process. At the core of it, we produce distortions based on scientific measurement. To achieve the desired end result in terms of graphic quality and registration to the form, the EI technology provides a graphics file precision-engineered for pre-decoration – regardless of the nature of the thermoform tooling design, substrate or print process associated with that particular part.

The technology is easily integrated into graphics and forming manufacturing environments through a simple qualification process to ensure repeatability. Basically, it's plug-n-play. Numerous thermoforming manufacturers without any previous experience with decorated sheet have easily applied the EI technology. EI technology seamlessly integrates with current and leading-edge 3D design, CAD and graphic technologies.

## *What is the difference from status quo?*

The previous state-of-the-art for distorting graphics was just that – an art form. It was a combination of trial-and-error methods and know-how based on experience. Designers and manufacturers worked within highly restricted design parameters and with a strong element of risk and unpredictability associated with quality, delivery time, and cost.

EI introduces an automated digital technology, which renders previous design limitations a thing of the past. Leveraging EI's technology opens graphics and tooling design to a new world of opportunities. Manufacturers can stretch the limits for product design with delivery certainty. Three-dimensional parts with world-class graphics are the new benchmark for decorated plastics.



## *Who can benefit from your technology?*

Current clients include thermoformers, printers, advertising agencies, merchandisers, gaming companies, packaging manufacturers, outdoor advertisers, promotional companies and vending manufacturers. Any groups within the value chain of all segments of the decorated plastics industry benefit from application of the technology.

## *Where do you see Elastic Image in the future?*

Elastic Image proprietary technology is rapidly emerging as the world standard platform for distorting graphics. ■

These sponsors enable us to publish **THERMOFORMING QUARTERLY**

PERFORMANCE. INNOVATION. DEPENDABILITY.



## Proven Partnership. Worldwide Benefits.

For the best in trim-in-place and high volume thermoforming equipment, parts and service, talk to the global experts at Lyle and Gabler. **Call 989-435-7717** for details, or visit [lyleindustries.com](http://lyleindustries.com).

**GABLER**  
Thermoform Technology  
[www.gabler-maschinenbau.de](http://www.gabler-maschinenbau.de)

**LYLE**  
THERMOFORMING EQUIPMENT  
4144 W. Lyle Road ■ Beaverton, MI 48612

*Please contact*

*Elastic Image, Inc.,*

*100 S. Campus Drive,*

*P.O. Box 3799,*

*Terre Haute, IN 47803,*

*1-812-244-4000, or visit*

*our website:*

*[www.elastic-image.com](http://www.elastic-image.com),*

*for more information.*

# History of Thermoforming – Part III

BY STANLEY R. ROSEN, PLASTIMACH CORPORATION, LAS VEGAS, NEVADA

*Ed. Note: The philosopher Santayana said “Those who cannot remember the past are destined to repeat it.” Stan Rosen is undertaking a prodigious project – identifying the pioneers who laid the foundations of the industry we know so well. Although shaping of sheet extends back to pre-history – oil-heated and shaped tortoise shell and steam-heated and shaped wood. In TFQ 24:3, Stan started his history with developments in the 1930s. We hope you are enjoying the trip!*

## Mechanically Forming Thermoplastics Parts Prior to the Thermoforming Age – Part One

Commercial thermoforming machinery and forming technology developed quickly in the U.S. during the early 1950s. Prior to that date, thermoplastics were most often formed mechanically using various methods by firms specializing in providing formed plastic products to their customers. These mechanical forming techniques were slow, labor intensive, and did not always provide reproducible results. Several visionary companies during this era invested in the design of thermoforming equipment to suit their own needs. However these machines were not sold on the open market. Borkland Laboratories licensed vacuum forming equipment in the late 1940s. Plax Corp. built and used automated thermoforming machines in the 1930s and Plaxall Corp. apparently built inline thermoformers for their own production in the early 1950s. A majority of the plastics fabricators continued to use mechanical forming techniques until commercial vacuum forming equipment was first publicly demonstrated at the National Plastics Exhibition in March 1952. Within one year, thermoforming activity expanded explosively as equipment and technical information became available to industry.

Mechanical forming of thermoplastic sheet borrowed some of the methods which were in use in the metal working and paper-box making industries. A metal deep drawing technique for fabricating a pot or pan from metal blanks was modified to process celluloid into seamless transparent packaging from individual plastic blanks. Paper box manufacturers employed die-cutting, creasing, bending and the cementing of box

corners for their products. Many of these paper box procedures were suitable for the production of plastic boxes and lids. Other forming processes modified from the glass blowing and metal forming industries were adapted to accommodate the physical properties of plastics materials.

Celluloid, a combination of cellulose nitrate, camphol and other chemical additives, was the first commercial plastic sheet available in 1868. Equipment to fabricate the sheet used a “blow form process” in which two heated celluloid sheets were placed between female molds and when the press was closed the cavity perimeter edges were trimmed and heat sealed together. Steam pressure then entered between the sheets to force the pre-heated plastic into the cavities. (Fig. 1, Fig. 2).

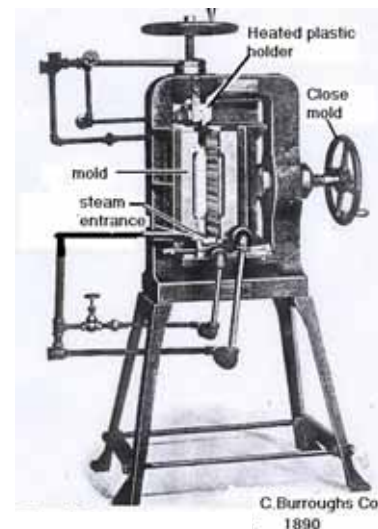

Figure 1. Blow-form press.

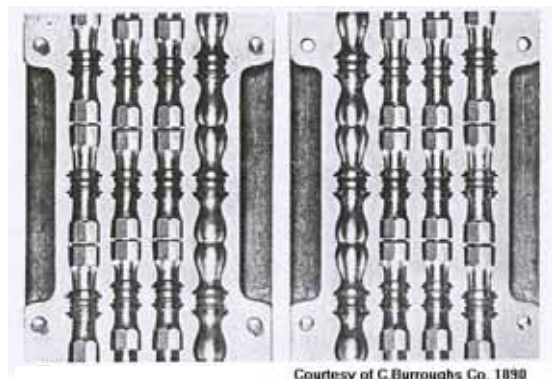

Figure 2. Blow-form mold.

(continued on next page)

(continued from previous page)

This process, which is similar to modern twin sheet-forming or blow molding, was used for production of double-faced parts such as balls, baby rattles, etc, starting in the 1890s. The same process could form one heated sheet into a female cavity producing shallow formed open-faced parts similar to a blister packaging component.

The city of Leominster, Massachusetts became the hub of the celluloid era (1900-1920) manufacturing activities and it pioneered in all types of plastics fabrication, especially blow forming. The ancillary components for manufacturing finished plastics components such as molds, presses and dies were manufactured here and sold worldwide. This pioneering city of the plastics industry is the home of the National Plastics Center and Museum where early plastics processing equipment is on display.

Manual deep drawing of thermoplastic sheets is described in a 1937 patent by William E. Helmstaedter, of the Celluloid Corp. (later Celanese Corp.) as follows (Fig. 3):

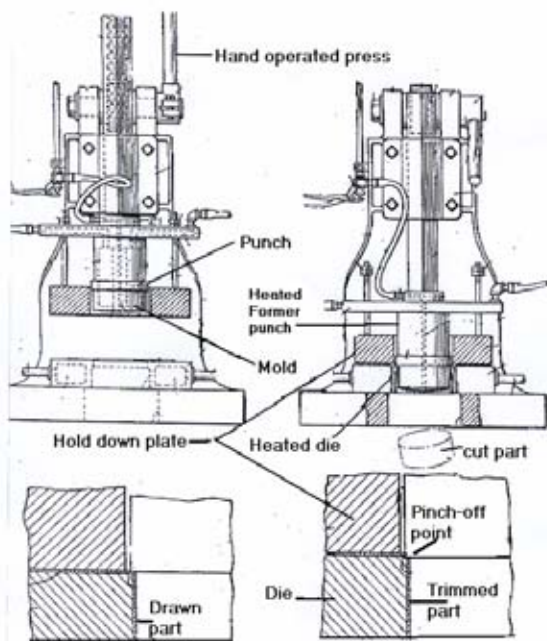

Figure 3. Manual deep drawing machine. Patent by H. E. Helmstaedter-1937.

A temperature-controlled “*former assembly*” consisting of a *male cavity* and a hardened cutoff *punch* is mounted to the top moving platen. The *punch* is located on the back face of the *male cavity*. The opposite stationary platen contains a heated *die* whose interior edge is rounded slightly to assist plastic flow between the *die* opening and onto the moving former. A heavy *hold-down plate* (much like a clamp frame), which

applies its weight to prevent the sheet from wrinkling during forming, allows the plastic flange to slip between the *hold-down plate* and the face of the hot *die*. This heated flange area provides the necessary additional material to form the finished part. Blanks thicker than .015 inch (.38 mm) require preheating in an oven and then are manually transported quickly to the forming press. Unlike the thermoforming process, where the heated sheet thins as it is being formed, deep drawing “steals” material from the flange as it slides between the *former* and the *die* and produces a fairly uniform sidewall.

Trimming and heat sealing of the finished drawn part edge takes place when the *punch* strikes the top surface of the *die*, causing the formed part to be trimmed by a heat pinch-off action. The more traditional punch and die design which is in more common usage in the industry allows the punch to cut through the plastic and enter the die cavity. Helmstaedter stated in the patent that a small temperature differential between a heated traditional punch and die could cause trimming problems. If the punch is cooler than the die, the tool clearance will increase and possibly cause a rough trimmed edge. A punch which is hotter than the die can reduce the clearance to zero causing a die smashup. These facts are recognized on modern thermoformers that form and trim in the same station using a punch and die, since this type of tooling receives considerable heat from the hot web. The control system of these newer machines can shut down the equipment if they detect an unsafe temperature differential between the two halves of the tool. ■

[To be continued]

## References

- Automatic Pressure Thermoforming, Plaxall Corp. L.I.C. N.Y
- Modern Plastics Magazine, July 1953.
- Inline Roll Fed Thermoformer, C. B. Strauch Patent #2,229,613 filed 11-22-1938 assigned to Plax Corp. Hartford, Conn.
- Vacuum Forming Machine, G. W. Borkland Patent #2,347,806 filed 7-8-1947 assigned to Borkland Laboratories, Marion, Ind.
- Fig. 1 and Fig. 2 - Plastics History U.S.A., J. H. Dubois – 1972, pgs. 45 and 347.
- Fig. 3 - Manual Deep Drawing of Plastics Packaging, W. E. Helmstaedter, Patent #2,255,116 filed 1-21-1937 assigned to Celluloid Corp., Newark, N. J.

# Draft Angles

BY JIM THRONE, SHERWOOD TECHNOLOGIES, INC., DUNEDIN, FL

Some time ago, we discussed shrinkage and warpage. At that time, we pointed out that plastic, like most other materials, increases in volume when heated and decreases in volume when cooled. And we said that to form the desired shape, the hot plastic is pushed against a cool mold surface. It follows that as the plastic cools, it shrinks. But the mold doesn't change in dimension. If the mold is male or positive, or if even a portion of the mold is male or positive, the plastic will shrink onto the mold surface. And if the mold is not properly designed, we will have a devil of a time getting the part off it. Thus we face the subject of draft angles.

## *Draft Angles – Defined*

The best definition of a draft angle is the angle the mold wall makes with the vertical. If the mold wall is vertical, the draft angle is zero. Recall that most thermoforming molds are single-surfaced. That is, the sheet is pulled into or over a single mold surface. For draw-down into a female or negative mold, the sheet is constrained on its outer surface by the mold. As a result, when the sheet cools, it tends to shrink away from the mold surface. As a result, it is

<sup>1</sup> These parts are sometimes called androgynous, meaning that they have both female and male characteristics.

<sup>2</sup> Exacerbate: To aggravate.



## **THERMOFORMING 101**

entirely feasible to thermoform into a female mold having zero draft angles. Most part designers prefer a slight draft angle, say 0° to 2°, “just in case.” The average is generally 1/2° to 1°.

On the other hand, when the sheet is drawn over a male or positive mold, it is constrained on its inner surface by the mold. As a result, when the sheet cools, it tends to shrink onto the mold surface. To release the part from the mold, it is necessary to provide a draft angle on the vertical mold surfaces. The amount of draft depends strongly on the volumetric change in the polymer. If the polymer is amorphous – PS, PVC, PC – the draft angle may be no more than 2° to 3°. If the polymer is crystalline – PE, PE – the draft angle may be in excess of 5°. The average is generally 4° but the designer must be alert to effects of temperature variation and recrystallization rates.

A textured surface requires an increase in draft angle. It is recommended that the draft angle be increased at least 1° for every 0.2 mils [0.0002 in or 5

microns] in texture depth. Keep in mind that increasing applied pressure, sheet temperature, and mold temperature will result in greater penetration of the sheet into the texture.

## *What About Parts With Male and Female Components?*

Multiple-compartment trays and pallets<sup>1</sup> can pose series drafting issues. Consider a female cavity bordered by two male segments. The sheet will attempt to shrink away from the female mold surface but onto the male segments. Excessive draft on the male segments may allow the sheet to release from the female mold surface before the sheet has replicated the mold surface. On the other hand, inadequate draft on the male segments may allow the sheet to satisfactorily form the female mold surface, but the sheet may “lock” onto the male segments. The problem is exacerbated<sup>2</sup> when molding compartment trays where the male portions are

*(continued on next page)*

(continued from previous page)

interrupted. Essentially interrupted walls in the molded part. In addition to the shrinkage issues, interrupted male segments may also be sources of internal webbing<sup>3</sup>.

## *How Serious is the Draft Problem?*

The draft angle can lead to serious dimensional changes in the formed part. Consider a simple example, a 10-inch male mold. The vertical wall is 1 inch wide at the top. Consider a draft angle of 5°. The width at the bottom of the vertical wall is determined as follows:

The increased width on one side is  $10 \times \tan 5^\circ = 0.875$  in. The total width at the bottom is then  $1 + 2 \times 0.875 = 2.75$  in.

This is a substantial dimensional change in the thickness of the vertical wall.

## *When is the Draft Angle Not a Draft Angle at All?*

When it is used for something else. The classic example is the drink cup. The sidewalls are tapered as much as 20° for stacking purposes, not shrinkage. In multi-compartment parts, care must be taken in the design to accommodate both the draft angle required for shrinkage and the necessary stacking taper. Stacking lugs, stand-offs, or rings are often designed into complex parts, simply because it is not always possible to predict the exact local shrinkage. ■

**Keywords:** *draft angle, taper, shrinkage*

<sup>3</sup> Webbing will be discussed in a later lesson.

## **BOOK REVIEW**



M. W. Hill, **Measuring to Manage: Using Measurable Data to Get Maximum Employee Performance**, paperback, 2003, 88 pages, \$16.95 + \$3.00 S+H. Order directly from Michael Hill, P. O. Box 20522, Indianapolis, IN 46220-9998.

I am always skeptical of the schemes proposed in the help guides for managers, dozens of which are published each year. Most of these repeat the same or similar mantra regarding manager-employee goal setting and review procedures. I am always reminded of the Dilbert cartoon where his pointy-haired boss (aka PHB) presents Dilbert with a long list of projects. When Dilbert asks him which are A priority and which are B and C priority, PHB tells him that this is the A list and that he has yet to make up the B and C list.

Michael Hill is VP of an industrial distribution center with five branch locations and over 100 employees. He has been a member of SPE for more than 20 years and is past president of the International Association of Plastics Distributors. He has an MBA from St. Bonaventure University. Mr. Hill has written a modest book with a very modest goal and has published it at a very modest price. According to the introduction, it “deals with teaching managers to achieve their goals by using measurable criteria to evaluate employee performance.” The book has 11 chapters – Problems in Today’s Climate, What a Company Should Do, Setting Your Evaluation Goals, Measuring, “Your” Evaluation, Pre-Review Tips, Examples, The Actual Review, Future Encouragement, When All

Else Fails, and Final Word on Measuring.

In addition to being very readable, the book contains many quotable statements. For example:

“A mediocre product ... with good people will easily outperform a great product marketed by a weak organization.”

“A goal, by definition, needs to be measurable ...”

“Don’t risk losing your investment in your employees due to poor management.”

“Reviews based on measurable criteria hold no surprises for the employee ...”

“Always be on the lookout for measurable criteria ...”

“... every company wants ... employees [to accept] responsibility for their actions, and in fact [to review] themselves.”

Hill argues that performance review and salary review should be separate entities. And that performance review has three components – management preparation, human resource input, and employee preparation. His mantra can probably be summarized by this:

“Without a yardstick there is no measurement. And without measurement, there is no control.” Toward this, he outlines a five-step program for achieving quality employee reviews.

Hill’s book is a fast read, with his thesis outlined only after he has “set the table” by discussing the failure aspects of other types of review. The reader should be fully aware that Hill’s proposed program needs to be designed by each manager to meet the needs of his/her employee team. And that this design is the sole responsibility of the manager. Hill’s thesis is technically viable so long as the manager-employee structure remains stable over an extended period of time.



But this reviewer sees three aspects of the proposal that remain largely unaddressed. The first deals with quixotic managers who consider reorganization as part of their obligation. Reorganizing employees and employee responsibilities on a frequent basis does not lead to development of dedicated people. The second deals with the reality of today's market. Very often, companies have extremely skilled and dedicated people who are working in areas being marginalized by shifting markets. Acquisitions, mergers, and buyouts enable a company to rapidly shift to the newly emerging markets, but unfortunately often force the company to surplus their best workers who simply cannot be retrained fast enough. And the third deals with rating managers. Too often, employees have no way of measuring the effectiveness of their manager to manage them. Managers may be oblivious to mannerisms or actions that, while "politically correct," irritate and annoy their people. This is particularly true of managers who manage by the book rather than lead by example.

So, is this a book that every manager should read? Sure. It has far more substance and is much easier to digest than do some of the weekly columns in the Wall Street Journal. But it is this reader's belief that good managers should purchase copies for each of their employees. The employee would then be aware of the reasons behind the five-step criteria being used to rate him or her. After all, even Hill says that "[w]hen company information and company goals are shared and agreed upon, everyone wins."

I rate this modest effort a strong four-and-a-half books out of five.



~ Jim Throne, Tech Editor

These sponsors enable us to publish **THERMOFORMING QUARTERLY**

**SOLAR KOTE®**

Acrylic Capstock and Film

**Capstock solutions for thermoformed sheet.**

- Outstanding for ABS, PC/ABS, PVC and HIPS
- Weatherable and easy to fabricate
- Excellent gloss control – from flat matte to ultra high gloss
- Chemical-, scratch- and UV-resistant
- Available in metallic, clear or any color

[www.solarkote.com](http://www.solarkote.com)

Phone: 215.419.7982

Fax: 215.419.5512

E-mail: [andrew.horvath@altuglasint.com](mailto:andrew.horvath@altuglasint.com)

**ALTUGLAS**  
INTERNATIONAL  
ARKEMA GROUP

Altuglas® and Solarkote® are registered trademarks belonging to Arkema.  
© 2005 Arkema Inc. All rights reserved.

Sales of new and used plastic equipment



## Supplying the World with Plastic Processing Equipment

**Auctions • Appraisals • Liquidations**  
**New and Used Machinery Sales**  
**Thermoforming • Injection Molding • Extrusion**  
**Blow Molding • Rotational Molding**

**Why buy with Stopol:**

- ◆ If it is out there, we will find it. With our database of more than 27,000 companies, we will locate the equipment you need.
- ◆ Our expertise and knowledge will provide you with the best machines to meet your needs.
- ◆ Our vast inventory provides you with a variety of choices and alternatives.
- ◆ Photos and video footage are available.

**Why sell with Stopol:**

- ◆ Actively market your equipment to more than 27,000 companies, utilizing phone, fax, email and advertising campaigns to get your equipment in front of qualified buyers.
- ◆ We include your equipment on our web site which produces more than 125,000 hits per month.
- ◆ We team with the most recognized and trusted publications in the plastics industry -- *Plastics News*, *Modern Plastics*, *Plastics Hotline* and *Thermoforming Quarterly* -- to market your equipment.
- ◆ Global presence with offices in London and Shanghai.

**Whether its remarketed plastics processing equipment, a plant auction, inventory liquidation, or the sale and acquisition of a business, product line, or manufacturing license – Stopol is the resource.**

**STOPOL NEWS**

Lyle Industries, Inc. has announced the appointment of Stopol, Inc. as exclusive representatives to market the Lyle RFT Custom thermoformer and related equipment in North America. The RFT Custom offers complete form-trim stack capabilities in an economical, rugged package. Standard mold size is 32 x 36 inches. An available quick-change tooling package helps make the RFT Custom a versatile, efficient choice for a variety of applications, and the heavy duty construction helps ensure durability and precise thermoforming performance.

**Stopol Office- Europe**  
London Berkeley Square  
2nd Floor  
Berkeley SquareHouse  
London, W1J 6BDUK  
Phone: +44 (0) 207-887-6102  
Fax: +44 (0) 207-887-6100  
[Eu\\_sales@stopol.com](mailto:Eu_sales@stopol.com)

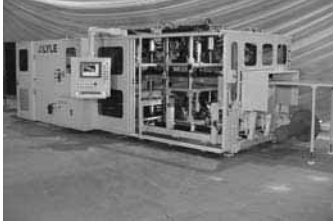

**Stopol Office - Asia**  
Shanghai One Corporate Center  
15F One Corporate Avenue  
22 Hu Bin Road  
LuWan District  
Phone: +86 21 6122 1302  
Fax: +86 21 6122 2418  
[Ap\\_sales@stopol.com](mailto:Ap_sales@stopol.com)

**STOPOL, Inc., 31875 Solon Road, Solon, OH 44139 U.S.A.**  
Ph: (440) 498-4000 • Fax: (440) 498-4001 • [www.stopol.com](http://www.stopol.com)



**2006 THERMOFORMING CONFERENCE**  
**SEPTEMBER 17-20**  
 NASHVILLE CONVENTION CENTER & RENAISSANCE HOTEL  
 NASHVILLE, TENNESSEE, USA



NAME: \_\_\_\_\_ SPE MEMBER #: \_\_\_\_\_

COMPANY: \_\_\_\_\_ TITLE: \_\_\_\_\_

(✓) ONE:  HOME ADDRESS  WORK ADDRESS DOB: \_\_\_/\_\_\_/\_\_\_ (only if applying for membership)

ADDRESS: \_\_\_\_\_

CITY: \_\_\_\_\_ STATE: \_\_\_\_\_ COUNTRY: \_\_\_\_\_ ZIP/POSTAL CODE \_\_\_\_\_

PHONE: \_\_\_\_\_ FAX: \_\_\_\_\_ E-MAIL: \_\_\_\_\_

(✓) ALL THAT APPLY:  THERMOFORMER  EXHIBITOR  OTHER \_\_\_\_\_

**FULL-CONFERENCE REGISTRATION**

\$ \_\_\_\_\_

*Includes All Technical Sessions, Exhibits, Plant Tours, Special Events and Meals*

**Early Registration**

SPE Member Rate - \$395  New Member Rate with SPE Membership - \$505  Nonmember Rate without SPE Membership- \$525  
 (\$110 Membership + \$395 Conference Registration)

**After August 15<sup>th</sup> / Onsite**

SPE Member Rate - \$495  New Member Rate with SPE Membership - \$605  Nonmember Rate without SPE Membership- \$625  
 (\$110 Membership + \$495 Conference Registration)



**RENEW YOUR MEMBERSHIP** *(Reduced membership rate for conference attendees)*

\$ \_\_\_\_\_

I would like to renew my SPE membership - \$110

**WORKSHOPS** *(included with full registration)*

(✓) One for Sunday, September 17

- McConnell-Buckel Cut Sheet (attendance limited to 150)
- Throne Roll Fed (attendance limited to 100)
- Process Control (attendance limited to 50)
- Doing Business in India (attendance limited to 35)

(✓) One for Wednesday, September 20

- Geiss Workshop (attendance limited to 100)
- Extrusion Workshop (attendance limited to 100)

*Presented by the SPE Extrusion Division*

**ONE-DAY FULL-CONFERENCE REGISTRATION** *(Sessions, Exhibits & Meals)*

\$ \_\_\_\_\_

Early Registration  SPE Member Rate - \$200  Nonmember Rate - \$330  
 After August 15/Onsite  SPE Member Rate - \$250  Nonmember Rate - \$380

(✓) One:  Monday, September 18  Tuesday, September 19

**EXHIBIT-HALL ONLY** *(Does not Include Meals, Breaks, Workshops or Technical Sessions)*

\$ \_\_\_\_\_

Early Registration \$50 per day / \$75 both days  
 After August 15/Onsite \$75 per day / \$150 both days

(✓) One:  Monday, September 18  Tuesday, September 19

**TOTAL PAYMENT**

\$ \_\_\_\_\_

Check Enclosed  Visa  Master Card  American Express

CARD #: \_\_\_\_\_ NAME ON CARD: \_\_\_\_\_

SECURITY CODE: \_\_\_\_\_ EXPIRATION DATE: \_\_\_\_\_



*Visa/MasterCard: The 3-digit security code can be found on the back of your card in the signature strip.*

*American Express: The 4-digit security code can be found on the front of your card, directly over the last raised digit of your card number*

SIGNATURE: \_\_\_\_\_ DATE: \_\_\_\_\_

Send this form with payment to:

SPE 2006 Thermoforming Conference, 14 Fairfield Drive, Brookfield, CT 06804

For more information contact: Society of Plastics Engineers

Phone: (203) 740-5430

Fax: (203) 775-8490

E-Mail: conferences@4spe.org

**PRE-REGISTRATIONS ARE NON-REFUNDABLE AFTER AUGUST 15, 2006**

*All cancellations must be made with the designated hotel by August 13, 2006.*

*Cancellations made after August 13, 2006 will result in the forfeiture of one night's deposit*

## Want to improve your thermoforming process?

Raytek delivers results you can see with the TF100 thermal process system:

- Reduce set-up time by 50%
- Increase throughput and profitability
- Improve product quality and uniformity
- Corrected thermal images on rotary and inline machines
- Automatically detect failed heating elements
- View and save thermal images for every part
- Eliminate guesswork from heater adjustments
- Quickly verify new tools and new molds
- Reduce scrap

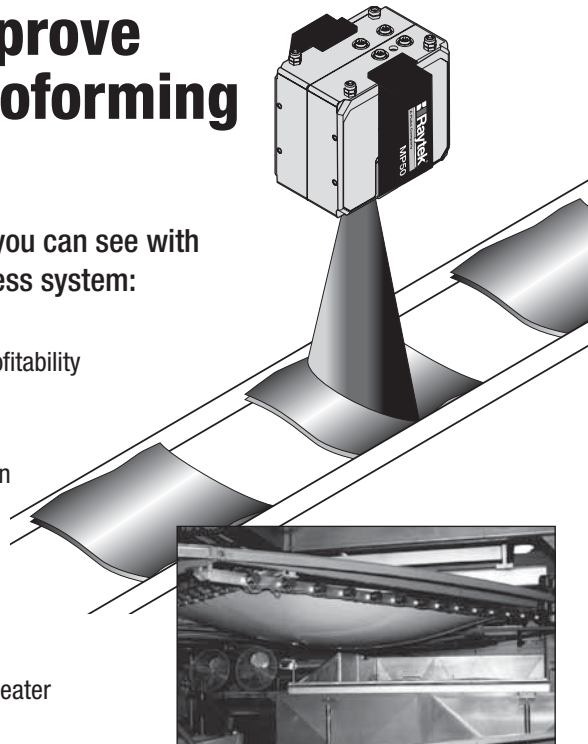

**Raytek**  
A Fluke Company

[www.raytek.com/tfresults](http://www.raytek.com/tfresults) • 1-800-227-8074



**Worldwide leader in noncontact temperature measurement for the thermoforming industry**

**Register Today and Save \$100**

### Industrial Thermoforming Symposium & Workshop

For Thin & Heavy Gauge Thermoforming

March 6-10, 2006

Crowne Plaza  
Dallas, Texas

Symposium Leader: William "Bill" K. McConnell, Jr.  
Guest speakers will provide various presentations

- Review the basic concepts of thermoforming and expand your understanding of thermosets and thermoplastics
- Plant tours, group lunches, sponsored receptions and dinner will encourage maximum exposure and interaction between attendees and professional leaders in

Tours include guided visits of:

Spartech Plastics - a custom sheet extrusion plant  
Better Bath Components - a large, cut-sheet, custom thermoforming plant  
Skyline Career Development Center - a career development high school's plastics shop

Presented by the Society of Plastics Engineers  
with the Thermoforming Division



For detailed information & registration visit [www.4spe.org/training/seminars](http://www.4spe.org/training/seminars)

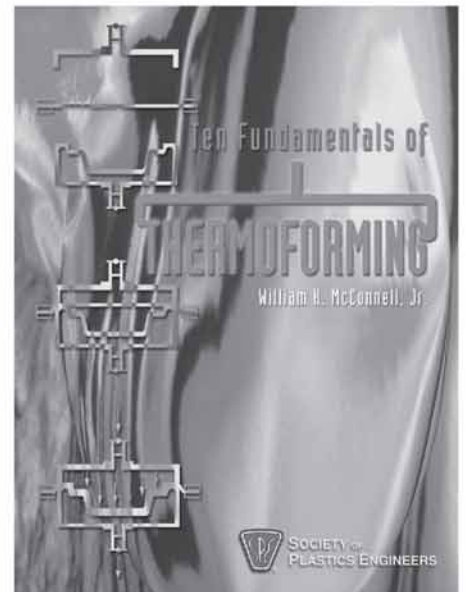

## DVD or Video Series & Companion Volume

- Based on Bill McConnell's Seminar and Workshop Series
- Heavy & Thin Gauge Thermoforming
- Methods, Materials, Production, Tooling, Mold/Product Design
- Vacuum and Compressed Air Systems, Best Practices, Heating of Film and Sheet & Heating System Requirements
- Filmed at four plant locations
- 200-page Companion Volume parallels video program and includes useful tables, charts and checklists
- The only Thermoforming Training in the marketplace

## Ten Fundamentals of THERMOFORMING

by SPE and Bill McConnell (#0190)

[www.4spe.org](http://www.4spe.org)

email: [bookstore@4spe.org](mailto:bookstore@4spe.org)

## What Are You Getting Yourself Into?

ALICE BLANCO, SENIOR ASSOCIATE EDITOR, PLASTICS ENGINEERING MAGAZINE

January is National Mentoring Month. There are many ways to become involved with mentoring. One of the best is for companies to offer internships to university students studying for a career in plastics. Student internships might help slow the long-term erosion of the manufacturing sector in the U.S., and there are many other benefits as well. What are those benefits? Ask Joe Peters, president of Universal Plastics in Holyoke, Mass. Ask Lucas Stallbaumer, a student of plastics engineering technology at Pittsburg State University in Pittsburg, Kansas. Here is their story.

Lucas Stallbaumer wanted to know what he was getting himself into. At the end of his junior year at Pittsburg State – pursuing a bachelor's degree in plastics engineering technology, with an emphasis in manufacturing – Lucas decided to apply for a summer internship. He desired “hands-on” working experience at a plastics company. Lucas also wanted a change of scenery: he had never seen the ocean.

When Bill McConnell of McConnell Co., Inc., a member of the Board of Directors of SPE's Thermoforming Division and a member of Pittsburg State University's Plastics Advisory Council, spoke to Lucas and fellow students enrolled in plastics technology classes, he provided a list of companies specializing in thermoforming that might welcome student interns. Lucas emailed all the companies on the

list. He received responses – and offers of internships – from two.

Lucas accepted the offer from Joe Peters, president of Universal Plastics in Holyoke, Mass., and his summer-of-2005 internship began. On May 29, Lucas boarded Southwest Airlines flight 132 K in Kansas City, bound for Massachusetts. His mother was not as excited about the trip as Lucas was. “My mom cried most of the way to the airport,” he recalls. Rich and Sue Peters (Joe's brother and sister-in-law) shared their home in Westfield, Mass., with Lucas for the summer. “I was welcomed and treated as part of the family. For this I am really thankful. It sure beat staying in a dorm room,” says Lucas.

At Universal Plastics, Lucas settled in with his own desk and computer in the engineering department. Joe Peters wanted to make sure that during the summer, Lucas's work duties took him into every area of the shop – from actually forming some parts to working with tooling and secondary operations. “I wanted him to work with engineers, supervisors, and line employees,” Joe says. Lucas was involved in new and ongoing projects, and was given a number of tasks, such as helping to design a package, testing designs, and sourcing materials and hardware for products the company manufactures.

His number-one job, reports Lucas, was assisting the company's forming department by creating computer spreadsheets that listed data pertaining to the forming of

parts. The easy accessibility of Lucas's electronic data sheets eliminated the need to shuffle through piles of unorganized papers in search of a particular document (if indeed one was to be found) and greatly facilitated the search for information on a particular part to be set up on a machine for production. Working on the spreadsheets familiarized Lucas with the materials being used, heating and cooling times, mold temperatures, forming pressures, and the PLCs (programmable logic controllers) of various machines, he says. Joe reports that Lucas's computer skills were highly valuable to the company: “He was in demand when others found out that he was great at designing forms.”

The most important thing Lucas learned during his internship: in the real world of producing parts, “things can become very frustrating very fast if things do not go right, but you have to keep your cool and get the job accomplished.” In helping with the thermoforming of 5-inch polyurethane cones, for example, Lucas observed that frequent and capricious changes in processing parameters (e.g., humidity, temperature, material thickness, and air pressure) make it challenging to produce consistent web-free parts that are neither too thin nor too short, and to produce them on time. Lucas was also absorbed in figuring out the process needed to apply large printed vinyl stickers to street signs. The stickers had to be perfectly centered and straight,

with no distortions in the print at all and no air bubbles or water intrusion, which would void the manufacturer's warranty. It was a hurry-up job to meet the customer's demand for a short turnaround time.

In an academic setting, one might encounter a difficult problem, postpone a solution, and return to deal with it another day. In the business world, walking away even temporarily from an unsolved problem is not an option. An idle machine shrinks a company's profits, and poor-quality parts or parts delivered late make for disgruntled customers, who might take future business elsewhere. Lucas points out: "So your company loses money and you could lose your job."

Throughout his internship at Universal Plastics, Lucas says, he learned lessons he did not expect to. "I learned the key aspects of business – from engineering to sales, research, forming, machining, quality control, and shipping. I learned a lot from all the steps involved in the entire business." Lucas also established business relationships and friendships with his coworkers that he thinks will last a lifetime. "I would suggest more students take part in an internship before they get into the workforce, to see what they are actually getting themselves into," he says.

Lucas thinks more companies should approach local colleges to seek interns, to train students in hopes that upon graduation they will join the staff as permanent employees. "That way," he says, companies "will not have to spend as much time or money familiarizing them with procedures, processes, machines, people, and other things that make a company run."

Joe Peters says, "Unfortunately, kids today are not being exposed to manufacturing and engineering

as a career path. They are not aware of the technology involved and the many rewards of creating and manufacturing products. Giving them an opportunity to spend some time [in the work environment] is invaluable in helping them make their career decisions." Furthermore, he adds, in the U.S. the reality is that we have to do as much as we can to promote manufacturing, which is quickly diminishing as an economic force in our country. Helping students acquire first-hand experience is an extremely valuable tool.

By the way, Lucas did get to see the ocean – at the Peters family's vacation home in Maine. He walked the beach, dined on lobster, and sailed on the Atlantic. He helped hoist the mast and sail the boat, and even accompanied the Peters' son Andrew on a flying lesson. Andrew's aerial stunts – spinning in circles, ascending straight up, and killing and recovering the engine – made him a bit dizzy, Lucas admits, but the scenery below was beautiful. ■



*Joe Peters, president of Universal Plastics, invited Lucas Stallbaumer, a student of plastics engineering technology at Pittsburg State University, Kansas, to spend the summer as an intern at his company in Holyoke, Massachusetts.*

## In Memory of R. Lewis Blanchard

### Past Thermoformer of the Year

It is with sadness that we announce the passing of R. Lewis (Lew) Blanchard. Lew passed away on December 12th, 2005 at his home in Lafayette, Indiana.

He began his career in thermoforming at Dow Chemical in Midland, where he worked on all phases of heat fabrication of thermoplastic materials and PVC formulations. As a representative of Dow, he helped start Sweetheart Plastics' first thermoforming plant.

While at Dawbarn Brothers in Waynesboro, VA, he developed the first process for polypropylene heavy denier fibers and strapping and worked on polyethylene fibers. At Kent Plastic Corp. in Evansville, his work included developing sheet extrusion and thermoforming of refrigerator door liners as well as thermoformed end caps for fiber cans, cottage cheese containers, flower pots and closures for recloseable cans.

He was inducted in the Plastics Hall of Fame and was also the 1994 Thermoformer of the Year. Lew was very active in the Society of Plastics Engineers, serving as Chairman of the Thermoforming Division and a member of their Board of Directors.

Lew is survived by his wife Pat and three daughters.

The Society of Plastics Engineers and the Thermoforming Division mourns the death of a dear friend and loyal member of this group. He will be missed. ■

# THERMOFORMING QUARTERLY INDEX

[The *Thermoforming Quarterly* was established at the beginning of 1998 and evolved from *Thermoforming*, the newsletter of the Thermoforming Division of SPE. Volume 17 Number 1 was the first issue of TFQ. Volume 19 Number 1 carried the Index from 17:1 through 18:4. Volume 21 Number 1 carried the Index from 19:1 through 20:4. Volume 23 Number 1 carried the Index from 21:1 through 22:4. This issue continues the Index from 23:1 through 24:4.]

## Index of Technical Articles by Issue

### TFQ 23:1, 2004

Industry Spotlight: Shepherd Thermoforming and Packaging, Inc., *The Birth of a Custom Thermoforming Operation*, pp. 5-8.  
*The Efficiencies of Infrared Heating Technologies Used in the Thermoforming Industry*, N. Bedard and S. Marchand, pp. 10-15.  
*The Role of Preheaters in Thin-Gauge Forming*, J.L. Throne, pg. 16.  
TF 101 – *Recrystallization-What Does That Mean?*, pp. 18-19.  
Book Review – *eBay on the Internet*, pp. 20-21.

### TFQ 23:2, 2004

*Optimization of Acrylic-Capped ABS Coextruded Systems For Sheet Applications*, H. R. Banyay and T. Pope, pp. 10-15.  
*Designing Knife-Like Dies for On-Line Continuous Web Thermoforming*, S. R. Rosen, pp. 16-19.  
*A Thermoforming Transatlantic Divide?*, C. Carlin, pp. 20-21.  
TF 101: *Alphabet Soup?*, pp. 22-24.  
Book Review: C. P. MacDermott and A. V. Shenoy, *Selecting Thermoplastics for Engineering Applications*, pp. 26-27.

### TFQ 23:3, 2004

*Optimization of Processing Conditions in Thermoforming*, C.M. Bordonaro, T. L. Virkler, P. A. Galante, B. Pineo, and C. E. Scott, pp. 8-13.  
*4<sup>th</sup> European Thermoforming Conference, March 25-27, 2004 – Viareggio, Italy*, C. Carlin, pp. 14-15.  
TF 101: *ABCs of Alphabet Soup*, pp. 18-19.  
Book Review: W. E. Brown, *Plastics in Food Packaging: Properties, Design, and Fabrication*, pp. 22-23.

### TFQ 23:4, 2004

*Interlayer Adhesion of Co-Extruded Sheets Before & After Biaxial Stretching*, H. Zhou, pp. 14-19.  
*Getting 411 on U. S. Patents*, J. K. Grogan, Esq., pp. 20-21.  
*Understanding & Using Appraisals: Five Ways They Can Be Used to Maximize Your Assets*, D. Kruschke, pp. 22-23.  
TF 101: *The XYZs of Alphabet Soup*, pp. 24-25.  
*RTP Company Opens New Sheet Extrusion Division*, Anon., pp. 27.  
Book Review: G. L. Beall and J. L. Throne, *Hollow Plastic Parts: Design and Manufacture*, pp. 28-30.

### TFQ 24:1, 2005

Spotlight on Industry: Productive Plastics, *Lean Manufacturing at Productive Plastics: A Customer-Driven Approach*, G. L. Bose and J. Zerillo, pp. 8-9.

*Neuronal Networks Application for Characterization of Softened Polymers*, F. Erchiqui and A.N. Kandil, pp. 10-15.  
University Highlight: Penn College, *Industry Support Helps College Promote Plastics Industry Careers*, pg. 16.  
*Energy Units in Thermoforming*, J.L. Throne, pg. 17.  
*Thermoforming: Growth and Evolution – Part I*, J. L. Throne and P. J. Mooney, pp. 18-20.  
TF 101: *Why is Part Design Important?*, pp. 22-23.  
Book Review: Penny Sparke, Ed., *The Plastics Age: From Bakelite to Beanbags and Beyond*, pg. 24.

### TFQ 24:2, 2005

*Automotive Plastic Fuel Tank Systems*, K. W. Albaugh, pp. 11-14.  
*Design Features of a Multi-Cavity Mold Used for High-Cyclic Thermoforming*, S. R. Rosen, pp. 15-18.  
*Thermoforming: Growth and Evolution – Part II*, J. L. Throne and P. J. Mooney, pp. 19-22.  
*Irwin Research and Wonderpack's Joint Venture*, Anon., pg. 23.  
TF 101: *Comparing Concept to Reality*, pp. 24-25.  
Book Review: D. C. Hylton, *Understanding Plastics Testing*, pg. 27.

### TFQ 24:3, 2005

*Enhanced TPO Thermoforming Using High Melt Strength Polyolefin Elastomers*, K. L. Walton, M. K. Laughner, L. J. Effler, and E. S. Gisler, pp. 10-14.  
*Collaborative and Methodical Product Development Reduces Time From Concept to Production*, E. Hausserman, pg. 15.  
*Proper Colleting and Collet Maintenance in CNC Routing of Plastic*, Van Niser, pp. 16-18.  
*History of Thermoforming – Part I*, S. R. Rosen, pp. 19-21.  
TF 101: *Understanding How a Sheet Stretches*, pp. 22-23.  
Book Review: G. L. Beall, *The Evolution of Plastics in America (As Seen Through the National Plastics Expositions)*, pp. 24-25.

### TF 24:4, 2005

*Investigation of Surface Properties of Pre-Stretching Plugs*, D. Liebing, N. Tessier, T. Bush, and P. Eyerer, pp. 18-22.  
*New CO<sub>2</sub> Laser Cutting Technology*, D. Cicchini, pp. 23-24.  
*History of Thermoforming – Part II*, S. R. Rosen, pp. 25-27.  
*Design of Experiments – An Overview*, D. Schoff, pp. 28-31.  
University Highlight: University of Wisconsin-Platteville, *UWP Plastics Processing Technology Center Receives Gift of Thermoforming Machine From MAAC and Division*, pg. 31.  
TF 101: *The Ubiquitous Draw Ratio*, pg. 32.  
Book Review: J. L. White and D. D. Choi, *Polyolefins: Processing, Structure Development and Properties*, pp. 34-35.

## Index of Technical and Industry Practice Articles by Author

K. W. Albaugh, *Automotive Plastic Fuel Tank Systems*, TFQ 24:2, pp. 11-14.  
H. R. Banyay and T. Pope, *Optimization of Acrylic-Capped ABS Coextruded Systems For Sheet Applications*, TFQ 23:2, pp. 10-15.  
N. Bedard and S. Marchand, *The Efficiencies of Infrared Heating Technologies Used in the Thermoforming Industry*, TFQ 23:1, pp. 10-15.

C.M. **Bordonaro**, T.L. Virkler, P.A. Galante, B. Pineo, and C.E. Scott, *Optimization of Processing Conditions in Thermoforming*, **TFQ 23:3**, pp. 8-13.

T. **Bush**, see D. Liebing.

C. **Carlin**, *A Thermoforming Transatlantic Divide?*, **TFQ 23:2**, pp. 20-21.

C. **Carlin**, *4<sup>th</sup> European Thermoforming Conference, March 25-27, 2004 - Viareggio, Italy*, **TFQ 23:3**, pp. 14-15.

D. **Cicchini**, *New CO<sub>2</sub> Laser Cutting Technology*, **TFQ 24:4**, pp. 23-24.

L. J. **Effler**, see K.L. Walton.

F. **Erchiqui** and A. N. Kandil, *Neuronal Networks Application for Characterization of Softened Polymers*, **TFQ 24:1**, pp. 10-15.

P. **Eyerer**, see D. Liebing.

P. A. **Galante**, see C. M. Bordonaro.

E. S. **Gisler**, see K. L. Walton.

J. K. **Grogan**, Esq., *Getting 411 on U.S. Patents*, **TFQ 23:4**, pp. 20-21.

E. **Hausserman**, *Collaborative and Methodical Product Development Reduces Time From Concept to Production*, **TFQ 24:3**, pp. 15.

A. N. **Kandil**, see F. Erchiqui.

D. **Kruschke**, *Understanding & Using Appraisals: Five Ways They Can Be Used to Maximize Your Assets*, **TFQ 23:4**, pp. 22-23.

M. K. **Laughner**, see K. L. Walton.

D. **Liebing**, N. Tessier, T. Bush, and P. Eyerer, *Investigation of Surface Properties of Pre-Stretching Plugs*, **TFQ 24:4**, pp. 18-22.

S. **Marchand**, see N. Bedard.

P. J. **Mooney**, see J. L. Throne.

B. **Pineo**, see C. M. Bordonaro.

T. **Pope**, see H. R. Banyay.

S. R. **Rosen**, *Designing Knife-Like Dies for On-Line Continuous Web Thermoforming*, **TFQ 23:2**, pp. 16-19.

S. R. **Rosen**, *Design Features of a Multi-Cavity Mold Used for High-Cyclic Thermoforming*, **TFQ 24:2**, pp. 15-18.

S. R. **Rosen**, *History of Thermoforming - Part I*, **TFQ 24:3**, pp. 19-21.

S. R. **Rosen**, *History of Thermoforming - Part II*, **TFQ 24:4**, pp. 25-27.

C. E. **Scott**, see C. M. Bordonaro.

D. **Schoff**, *Design of Experiments - An Overview*, **TFQ 24:4**, pp. 28-31.

N. **Tessier**, see D. Liebing.

J. L. **Throne**, *The Role of Preheaters in Thin-Gauge Forming*, **TFQ 23:1**, pp. 16.

J. L. **Throne**, *Energy Units in Thermoforming*, **TFQ 24:1**, pp. 17.

J.L. **Throne** and P.J. Mooney, *Thermoforming: Growth and Evolution - Part I*, **TFQ 24:1**, pp. 18-20.

J. L. **Throne** and P. J. Mooney, *Thermoforming: Growth and Evolution - Part II*, **TFQ 24:2**, pp. 19-22.

**Van Niser**, *Proper Collecting and Collet Maintenance in CNC Routing of Plastic*, **TFQ 24:3**, pp. 16-18.

T. L. **Virkler**, see C. M. Bordonaro.

K. L. **Walton**, M. K. Laughner, L. J. Effler, and E. S. Gisler, *Enhanced TPO Thermoforming Using High Melt Strength Polyolefin Elastomers*, **TFQ 24:3**, pp. 10-14.

H. **Zhou**, *Interlayer Adhesion of Co-Extruded Sheets Before & After Biaxial Stretching*, **TFQ 23:4**, pp. 14-19.

### Index of Continuing Series Titles

#### Industry Spotlight

Shepherd Thermoforming and Packaging, Inc., *The Birth of a Custom Thermoforming Operation*, **TFQ 23:1**, pp. 5-8.

Productive Plastics, *Lean Manufacturing at Productive Plastics: A Customer-Driven Approach*, G. L. Bose and J. Zerillo, **TFQ 24:1**, pp. 8-9.

#### University Spotlight

Penn College, *Industry Support Helps College Promote Plastics Industry Careers*, **TFQ 24:1**, pp. 16.

University of Wisconsin-Platteville, *UW-P Plastics Processing Technology Center Receives Gift of Thermoforming Machine From MAAC and Division*, **TFQ 24:4**, pp. 31.

#### Thermoforming 101

*Recrystallization - What Does That Mean?*, **TFQ 23:1**, pp. 18-19.

*Alphabet Soup?*, **TFQ 23:2**, pp. 22-24.

*ABCs of Alphabet Soup*, **TFQ 23:3**, pp. 18-19.

*The XYZs of Alphabet Soup*, **TFQ 23:4**, pp. 24-25.

*Why is Part Design Important?*, **TFQ 24:1**, pp. 22-23.

*Comparing Concept to Reality*, **TFQ 24:2**, pp. 24-25.

*Understanding How a Sheet Stretches*, **TFQ 24:3**, pp. 22-23.

*The Ubiquitous Draw Ratio*, **TFQ 24:4**, pp. 32.

### Book Review

G. L. **Beall** and J. L. Throne, *Hollow Plastic Parts: Design and Manufacture*, **TFQ 23:4**, pp. 28-30.

G. L. **Beall**, *The Evolution of Plastics in America (As Seen Through the National Plastics Expositions)*, **TFQ 24:3**, pp. 24-25.

W. E. **Brown**, *Plastics in Food Packaging: Properties, Design, and Fabrication*, **TFQ 23:3**, pp. 22-23.

D. D. **Choi**, see J. L. White.

*eBay on the Internet*, **TFQ 23:1**, pp. 20-21.

D. C. **Hylton**, *Understanding Plastics Testing*, **TFQ 24:2**, pp. 27.

C. P. **MacDermott** and A. V. Shenoy, *Selecting Thermoplastics for Engineering Applications*, **TFQ 23:2**, pp. 26-27.

A. V. **Shenoy**, see C. P. MacDermott.

Penny **Sparke**, Ed., *The Plastics Age: From Bakelite to Beanbags and Beyond*, **TFQ 24:1**, pp. 24.

J. L. **Throne**, see G. L. Beall.

J. L. **White** and D. D. Choi, *Polyolefins: Processing, Structure Development and Properties*, **TFQ 24:4**, pp. 34-35. ■

These sponsors enable us to publish **THERMOFORMING QUARTERLY**

**IN THE WORLD OF THERMOFORMING,  
We're Changing the Rules!**

Quality built, heavy duty machines, systems, components and accessories  
Advanced features -- faster, more cost-effective and longer lasting  
We not only meet, but often exceed, your production requirements  
Experience, reliability, integrity and follow through  
Designed for the application, your application  
Enhanced control over quality, speed  
Long lasting with quick payback  
Highly competitive pricing  
Unparalleled service  
On time deliveries  
Energy efficient  
Full Training

**ADVANCED VENTURES IN TECHNOLOGY, INC.**  
3870 West Highway M-61, Gladwin, MI 48624  
Tel: 989-246-0445 • Fax: 989-246-0465

Web: [www.adv-ven-tech.com](http://www.adv-ven-tech.com) • E-mail: [sales@adv-ven-tech.com](mailto:sales@adv-ven-tech.com)

**Manufacturers of the World's Largest Thermoforming Machine!**

**“FORMING  
EDUCATIONAL  
OPPORTUNITIES:  
GRANTS AND  
SCHOLARSHIPS  
OFFERED  
BY THE  
SOCIETY OF  
PLASTICS  
ENGINEERS –  
THERMOFORMING  
DIVISION”**

The Thermoforming Division of SPE has produced a new six-minute DVD for educators.

The DVD discusses the 13 matching equipment grants of up to \$10,000 and how to apply for the grant. The 20 scholarships to college students are discussed and information is provided as how to apply for a scholarship. The Thermoforming Division of SPE has contributed over \$150,000 in equipment grants and scholarships as of this date.

The DVD is free of charge and available from SPE through Gail Bristol at 203-740-5447 or Gwen Mathis, Thermoforming Division, at 706-235-9298.

These sponsors enable us to publish **THERMOFORMING QUARTERLY**

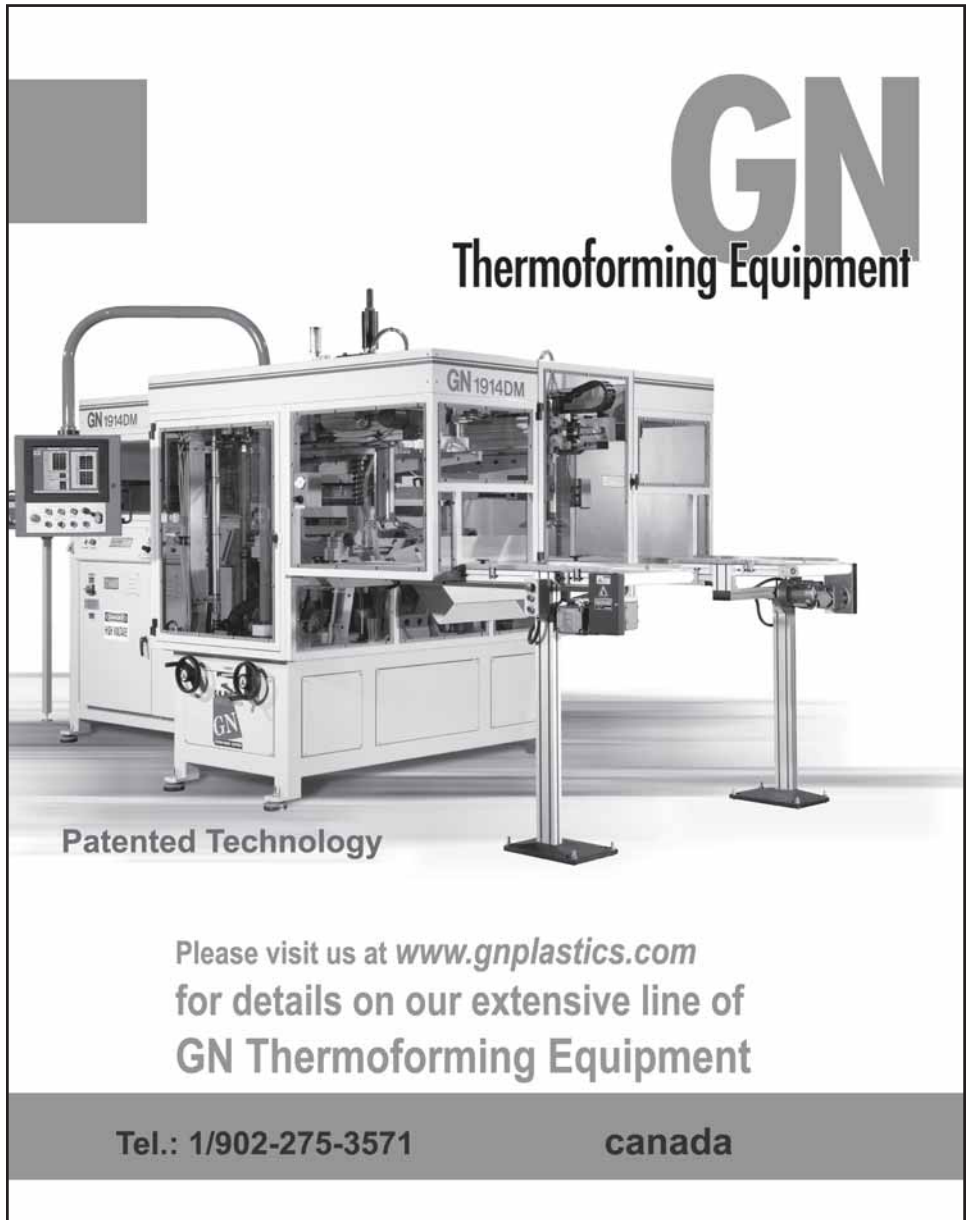

**GN**  
Thermoforming Equipment

GN 1914DM

Patented Technology

Please visit us at [www.gnplastics.com](http://www.gnplastics.com) for details on our extensive line of GN Thermoforming Equipment

Tel.: 1/902-275-3571      canada

THINK  
**THERMOFORMING**

**Think Onsrud, #1 Source of Cutting Tools to The Thermoforming Industry**

*Cutting Tools for ALL Trimming Applications*

- Multi-Axis Robotic Routers
- 3 and 5 Axis CNC Routers
- Hand-Held Routers

**ONSRUD**  
ONSRUD CUTTER LP  
800 Liberty Drive  
Libertyville, IL 60048, USA  
Ph: 800.234.1560 • Fax: 847.362.5028

**LMT** • Leitz Metalworking Technology Group

[www.onsrud.com](http://www.onsrud.com) • [www.plasticrouting.com](http://www.plasticrouting.com)



If you want to lead  
you have to get in-line.

By far, the most  
efficient way to  
produce  
thermoformed  
packaging  
is with a Welex  
In-Line Extrusion System.

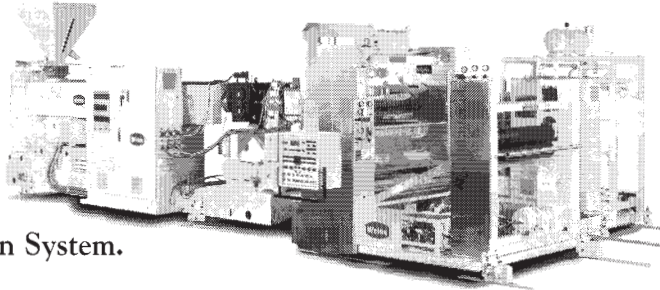

Welex Incorporated  
850 Jolly Road, Blue Bell, PA 19422  
Tel(215) 542-8000 FAX(215) 542-9841  
E-mail: welex@welex.com



**Thermo  
Forming**

**Division**

*Help Sponsor*

**THERMOFORMING®  
QUARTERLY**

**ONE YR. SPONSORSHIPS**

**\*\*Please note the increase in sponsorship rates. This is the first increase since the inception of the Thermoforming Quarterly in 1981. We appreciate your continued support of our award winning publication.**

**Patron - \$625**

(Includes 2.25" x 1.25" notice)

**Benefactor - \$2,000**

(Includes 4.75" x 3" notice)

**Questions?**

Please Contact:

**Laura Pichon**

Ex-Tech Plastics

815/678-2131 Ext. 624

lpichon@extechplastics.com

*We Appreciate Your Support!*

*Need to produce more quality parts per hour?*

Robotic Production Technology's  
family of reliable, flexible  
robotic trimming solutions  
can help you get the results you need.

We put the "expert" in expertise when it comes to plastic,  
composite and fabric trimming and routing.

**Get results**

*Produce more parts per hour,  
increase uptime  
and improve safety.*

**Benefits**

- Up to 50% higher throughput than a 5-axis CNC
- Automatic fixture location
- Automatic spindle realignment
- Automatic program call-up



Contact us today to get started!  
Robotic Production Technology  
(248) 829-2800  
www.RPT.net  
Solutions@RPT.net

**From The Editor**

*Thermoforming Quarterly* welcomes letters from its readers. All letters are subject to editing for clarity and space and must be signed. Send to: Mail Bag, Thermoforming Quarterly, P. O. Box 471, Lindale, Georgia 30147-1027, fax 706/295-4276 or e-mail to: gmathis224@aol.com.

These sponsors enable us to publish

## THERMOFORMING QUARTERLY



65 South Waukegan Road  
Lake Bluff, IL 60044

**Custom Engineered Plastic Parts**  
Vacuum • Pressure • Twin Sheet  
**We Deliver Parts Under Pressure!**

(847) 604-5100

FAX (847) 604-8030



[www.pcmwi.com](http://www.pcmwi.com)

**Quality Thermoform Molds**  
Since 1972

**Portage Casting & Mold, Inc.**  
2901 Portage Road, Portage, WI 53901  
1-800-356-5337 — Fax 1-608-742-2199

### McCONNELL CO., INC.

THERMOFORMING CONSULTANTS

Product Design & Development • Manufacturing Analysis  
In-Plant Seminars • Expert Witnesses  
Legal Research • Consulting

**817-926-8287**

Fax: 817-926-8298

3030 Sandage Ave.

E-mail: [info@thermoforming.com](mailto:info@thermoforming.com)

Fort Worth, TX 76109

PO Box 11512

76110

Visit our Internet website: <http://www.thermoforming.com>



**Productive Plastics, Inc.**  
*Award Winning Thermoforming*



103 West Park Drive • Mt. Laurel, NJ 08054  
(856) 778-4300 • Fax: (856) 234-3310  
<http://www.productiveplastics.com>

**Flameless  
Catalytic  
Infrared  
Gas Heaters**

- New, Used and Factory Refurbished Heaters
- On-site Refurbishing Services

**AMERICAN CATALYTIC TECHNOLOGIES**

Since 1992  
Brantford, CT 06405 • Phone 800-648-1698  
Fax 203-483-6693 • [www.americancatalytic.com](http://www.americancatalytic.com)

These sponsors enable us to publish **THERMOFORMING QUARTERLY**

## Rapidly Adjust the Heat of Your Sheet

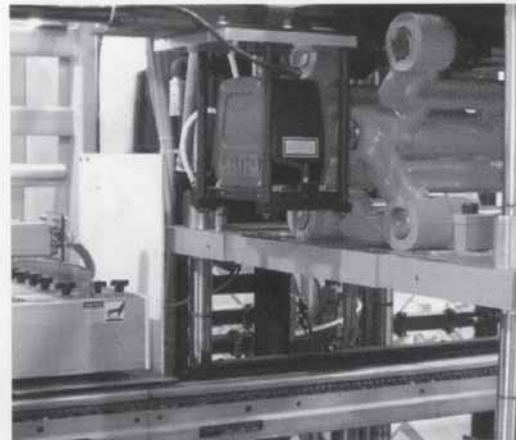

**Affordable, high quality process thermal imaging for when the heat is on ...**

**Landscan Pro LSP6 and LSP7** infrared linescanners produce accurate temperature profiles of thin and thick plastic sheet without contact.

- Powerful and Reliable Software
- Durable Sapphire Window
- 100 Hz Scan Rate
- 1000 Points per Scan Line
- 140F Ambient Without Cooling
- Integral Laser Sighting

**LAND**  
instruments international

An ISO 9001 & 17025 Company

Combustion & Environmental Monitoring  
Infrared Temperature Measurement

**Land Instruments International**

10 Friends Lane

Newtown, PA 18940

Phone: (215) 504-8000

E-Mail: [irsales@landinstruments.net](mailto:irsales@landinstruments.net)

[www.landinstruments.net](http://www.landinstruments.net)

Premier Material Concepts™  
*Your needs. Real solutions.*

**Premier Material Concepts™** is a custom extruder of sheet and roll stock.

We specialize in: Impact Modified Acrylic • ABS • TPO • TPE • PP • HIPS • PE • Specialty Compounds • Color Matching • UV Stabilizers

Please contact **PMC™** with your custom plastic and extrusion needs today!

1-877-BUY-PMC6 • [www.buypmc.com](http://www.buypmc.com) • [sales@buypmc.com](mailto:sales@buypmc.com)

Premier Material Concepts™ is a Rowmark® Company

**THERMOFORMERS, HAVE YOU DISCOVERED A FORMING TIP THAT YOU ARE WILLING TO SHARE WITH YOUR FELLOW FORMERS? A TIME SAVER? OR A COST SAVER? OR SOMETHING THAT WILL SAVE WEAR AND TEAR ON YOUR MACHINE? OR YOUR EMPLOYEES? THEN THE**

# Forming TIPS

**COLUMN IS FOR YOU!**

**Just send Jim Throne a fax at 727-734-5081, outlining your tip in less than a couple hundred words. You can include drawings, sketches, whatever. Thanks!**

These sponsors enable us to publish **THERMOFORMING QUARTERLY**

Serving the SPE since 1975  
 The Source for Used Thermoforming & Trimming Equipment

**plastIMACH**  
 CORP

We want to buy your surplus!      Equipment Appraisals      Financing Available

Visit us on the web for "realtime" inventory, complete with photos, videos, specs

Or Call us today to discuss your application and machine requirements

Featuring the  
**GNCROUTERSTORE.COM**

www.plastimach.com      3 and 5 axis routers      800-394-1128 tel

**IMAGINEERING SOLUTIONS**

*We will create a custom sheet solution for you at our new state-of-the-art extrusion facility, drawing upon RTP Company's vast array of specialty compounding technologies in:*

- Conductive
- Flame Retardant
- Structural
- TPE
- Wear
- Color

**RTP Co.**  
 Imagineering Plastics®

Tel (507) 454-6900  
 (800) 433-4787  
 www.rtpcompany.com

580 East Front Street, Winona, MN 55987

**BROWN® Machine**



Brown Machine, the industry leader since 1952, continues to expand and offer the most complete line of production thermoforming equipment. From entry-level machinery to advanced system automation, Brown Machine can support any and all of your cut sheet or in-line requirements including:

- Single Station Shuttle Thermoformers
- Vacuum Rotary Thermoformers
- Pressure Rotary Thermoformers
- Steel Rule Thermoformers
- In-Line Thermoformers
- Horizontal & Vertical Trim Presses
- Lip Rollers
- In-Line Tooling & Mold Components
- Remanufacture & Upgrade Kits
- 24/7 Parts & Service

Brown Machine LLC  
 330 North Ross Street  
 Beaverton, MI 48612-0434  
 USA

phone 989.435.7741  
 fax 989.435.2821  
 sales@brown-machine.com  
 www.brown-machine.com

# YOU ASKED



# WE LISTENED



Due to the many surveys requesting that we change the dates of the annual Thermoforming Conference, the Board has listened and beginning in 2006, we are pleased to announce the new dates.

Nashville 2006



"Creativity & Innovation in Thermoforming"

**Sunday,  
September 17  
through  
Wednesday,  
September 20,  
2006**

**Renaissance Nashville  
Hotel & Nashville  
Convention Center**

**General Chairman:  
Martin Stephenson  
Placon Corporation  
Phone: 608-275-7215  
E-Mail:  
[mstep@placon.com](mailto:mstep@placon.com)**

**Technical Chairman:  
Mike Lowery  
Premier Plastics  
Phone: 414-423-5940 Ext. 102  
E-Mail:  
[mikel@lowerytech.com](mailto:mikel@lowerytech.com)**

These sponsors enable us to publish **THERMOFORMING QUARTERLY**

## QUICK CHANGE CYLINDER LOCKS

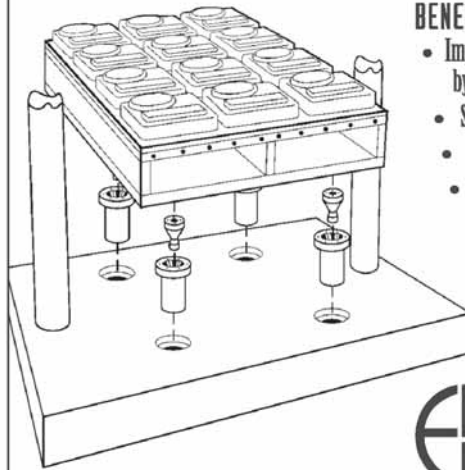

### BENEFITS...

- Improve tool change over times... by more than 50%
- Self aligning...precisely repeatable
- No bolts-no wrenches
- Adaptable to all tools and components
- Simple to install



➔ Call for our new catalog

Tel: 937.295.3672 [www.segen-online.com](http://www.segen-online.com)



**EDWARD D. SEGEN & CO., LLC**  
A TOOLING TECH GROUP COMPANY  
P.O. Box 319, 100 Enterprise Dr., Ft. Loramie, OH 45845



**ULTRA-METRIC TOOL CO.**

2952 N. Leavitt • Chicago IL 60618 • Ph (773) 281-4200 • Fax (773) 281-6185

## THERMOFORM TOOLING



FORM TOOLS

TRIM TOOLS

OPS PET PP HDPE  
EPS



PRECISION TOOLS FOR  
QUALITY THERMOFORM  
PRODUCTS

*We Design & Build Thermoform  
Tooling That Molds Relationships*

30+ Years of Superior Service:

- ◆ Complete Turnkey Service
- ◆ Product Design & Prototypes
- ◆ CAD/CAM Tool Engineering
- ◆ Continuous High Speed Tooling
- ◆ 3<sup>rd</sup> Motion Machine Driven
- ◆ Form & Trim-In-Line
- ◆ Form & Trim-In-Place
- ◆ Custom Built Mold Bases
- ◆ H<sub>2</sub>O Cooled Male/Female Molds
- ◆ Matched Metal Punch & Die Sets
- ◆ Large CNC Milling & CNC Turning
- ◆ Deep Hole Gun Drilling
- ◆ On-time Delivery

← [sales@umthermoform.com](mailto:sales@umthermoform.com)  
[www.umthermoform.com](http://www.umthermoform.com)



# Society of Plastics Engineers

P.O. Box 403, Brookfield, CT 06804-0403 USA  
Tel: +1.203.740.5403 Fax: +1.203.775.8490 www.4spe.org

# MEMBERSHIP APPLICATION

## Applicant Information

**Name:**  
first last mi

**Company Name and Business Address (or College):**  
company/college:  
job title:  
address:  
address:  
city: state:  
zip: country:

Phone/Fax Format: USA & Canada: (xxx) xxx-xxxx All Others: +xx(xx) x xxx xxxx

**Work Phone:** **Fax:**

**Email:** *used for society business only*

**Home Address:**  
address:  
city: state:  
zip: country:

**Home Phone:**

Preferred Mailing Address:  Home  Business

**Gender:**  Male  Female

**Birth Date:** (mm/dd/yyyy)

**Demographics**

**Job Function** (choose only one)

<input type="checkbox"/> Consulting	<input type="checkbox"/> Purchasing
<input type="checkbox"/> Design	<input type="checkbox"/> Quality Control
<input type="checkbox"/> Education (Faculty)	<input type="checkbox"/> R & D
<input type="checkbox"/> Engineer	<input type="checkbox"/> Retired
<input type="checkbox"/> General Management	<input type="checkbox"/> Self-Employed
<input type="checkbox"/> Manufacturing	<input type="checkbox"/> Student
<input type="checkbox"/> Marketing/Sales	<input type="checkbox"/> Tech Support
<input type="checkbox"/> Other	

**Materials** (choose all that apply)

<input type="checkbox"/> Composites	<input type="checkbox"/> Polyolefins
<input type="checkbox"/> Film	<input type="checkbox"/> Polystyrene
<input type="checkbox"/> General Interest	<input type="checkbox"/> TPEs
<input type="checkbox"/> Nylon	<input type="checkbox"/> Thermoset
<input type="checkbox"/> PET	<input type="checkbox"/> Vinyls
<input type="checkbox"/> Foam/Thermoplastics	<input type="checkbox"/> No Interest

**Process** (choose all that apply)

<input type="checkbox"/> Blow Molding	<input type="checkbox"/> Injection Molding
<input type="checkbox"/> Compression	<input type="checkbox"/> Mold Making
<input type="checkbox"/> Compounding	<input type="checkbox"/> Product Design
<input type="checkbox"/> Engineering Properties	<input type="checkbox"/> Rotational Molding
<input type="checkbox"/> Extrusion	<input type="checkbox"/> Thermoforming
<input type="checkbox"/> Fabrication	<input type="checkbox"/> General Interest
<input type="checkbox"/> Foam	<input type="checkbox"/> No Interest

The SPE Online Membership Directory is included with membership. Your information will automatically be included.

Exclude my email from the Online Member Directory  
 Exclude all my information from the Online Member Directory  
 Exclude my email from 3rd party mailings

## Payment Information

<b>New Member 1 Year</b>	<b>New Member 2 Years *</b>	<b>Student Member</b>	<input type="checkbox"/> US (\$122.00) <input type="checkbox"/> US (\$212.00) <input type="checkbox"/> US (\$28.00) <input type="checkbox"/> Canada (\$162.75) <input type="checkbox"/> Canada (\$282.00) <input type="checkbox"/> Canada (\$37.50) <input type="checkbox"/> Euro (€125.00) <input type="checkbox"/> Euro (€219.00) <input type="checkbox"/> Euro (€25.00)	<b>Students must supply graduation date:</b> _____
<b>My Primary Division is</b> (choose from below) _____				<b>Membership Amount</b> _____
<b>Additional Divisions are available for a fee. Check below to select Additional Divisions.</b>				<b>Primary Division</b> <b>FREE</b>

<input type="checkbox"/> Additives & Color Europe (D45) <input type="checkbox"/> Automotive (D31) <input type="checkbox"/> Blow Molding (D30) <input type="checkbox"/> Color & Appearance (D21) <input type="checkbox"/> Composites (D39) <input type="checkbox"/> Decorating & Assembly (D34) <input type="checkbox"/> Electrical & Electronic (D24) <input type="checkbox"/> Engineering Properties & Structure (D26) <input type="checkbox"/> Extrusion (D22) <input type="checkbox"/> Flexible Packaging (D44) <input type="checkbox"/> Injection Molding (D23) <input type="checkbox"/> Marketing & Management (D37)	<input type="checkbox"/> Medical Plastics (D36) <input type="checkbox"/> Mold Making & Mold Design (D35) <input type="checkbox"/> Plastics Environmental (D40) <input type="checkbox"/> Polymer Analysis (D33) <input type="checkbox"/> Polymer Modifiers & Additives (D38) <input type="checkbox"/> Product Design & Development (D41) <input type="checkbox"/> Rotational Molding (D42) <input type="checkbox"/> Thermoforming (D25) <input type="checkbox"/> Thermoforming, European (D43) <input type="checkbox"/> Thermoplastic Materials & Foams (D29) <input type="checkbox"/> Thermoset (D28) <input type="checkbox"/> Vinyl Plastics (D27)	<b>Additional Division(s)</b> costs for each Additional Division <table border="0"> <tr><td></td><td><b>1yr.</b></td><td><b>2 yrs.</b></td></tr> <tr><td>US</td><td>\$6.00</td><td>\$12.00</td></tr> <tr><td>Canada</td><td>\$8.00</td><td>\$16.00</td></tr> <tr><td>Euros</td><td>€5.00</td><td>€10.00</td></tr> </table>		<b>1yr.</b>	<b>2 yrs.</b>	US	\$6.00	\$12.00	Canada	\$8.00	\$16.00	Euros	€5.00	€10.00
	<b>1yr.</b>	<b>2 yrs.</b>												
US	\$6.00	\$12.00												
Canada	\$8.00	\$16.00												
Euros	€5.00	€10.00												

**TOTAL** \_\_\_\_\_

CHECK     VISA     AMEX     MASTERCARD

card number \_\_\_\_\_

expiration date (mm/yyyy) \_\_\_\_\_

**PAYMENT MUST ACCOMPANY APPLICATION**  
**Sorry, No Purchase Orders Accepted**

Checks must be drawn on US or Canadian banks in US or Canadian funds.  
Dues include a 1-year subscription to *Plastics Engineering* magazine.  
SPE membership is valid for twelve months from the month your application is processed.  
\*save over 10%

By signing below I agree to be governed by the Constitution and Bylaws of the Society and to promote the objectives of the Society. I certify that the statements made in the application are correct and I authorize SPE and its affiliates to use my phone, fax, address and email to contact me.

signature \_\_\_\_\_ date \_\_\_\_\_

recommended by member (optional) \_\_\_\_\_ Id # \_\_\_\_\_

These sponsors enable us to publish  
**THERMOFORMING  
QUARTERLY**

# ALLEN

CUSTOM THERMOPLASTIC SHEET

1305 Lincoln Avenue, Holland, MI 49423  
PH (800) 833-1305 / FX (800) 832-5536  
www.allenx.com

ABS	ABSFR	PCABS
HIPS	HIPSFR	GELLOY
CENTREX	LURAN	NORYL
	SOLARKOTE	

*A Tradition of Excellence Since 1970*

50 YEARS PROVIDING

# SOLUTIONS

IN PLASTICS



McClarin Plastics, Inc.

800-233-3189  
717-637-2241 • Fax: 717-637-2091  
600 Linden Avenue  
Hanover, PA 17331  
www.McClarinPlastics.com  
E-Mail: mcclarin@mcclarinplastics.com

# PRIMEX

PLASTICS CORPORATION

*A Quality Custom Sheet Extruder!*

Polystyrene	Polyethylene	ABS
Polypropylene	Polyester	Cor-x

1-800-222-5116

www.primexplastics.com

Large enough to handle your requirements,  
Small enough to handle your needs...

# ZED

INDUSTRIES, INC.

*The Best In*

Thermoforming Machinery,  
Tooling, and Automation Solutions

3580 Lightner Rd. Vandalia, Ohio  
(937)-667-8407, Fax (937)-667-3340  
E-Mail: Info@ZedIndustries.com

# THE FOXMOR

GROUP, INC.

Serving the Plastics Industry with Expertise and Integrity.

Roger Fox David A. J. Morgese

(630) 653-2200

www.foxmor.com

These sponsors enable us to publish **THERMOFORMING QUARTERLY**



*Innovative Tooling Materials for Thermoforming*

# HYTAC<sup>®</sup>-WFT

Plug Assist Material

The First Syntactic to Meet FDA and European  
Compliance for Food Packaging



CMT MATERIALS, INC.

info@cmtmaterials.com

www.cmtmaterials.com

TEL (508) 226-3901

FAX (508) 226-3902

## WORLD CLASS SHEET EXTRUSION SYSTEMS

PTi Trident Series™ Model 8000  
Ultra High Capacity Multi-Layer  
Inline Sheet Production  
System for PP, PS,  
PE, APET and  
others!



*Specializing in...*  
**Cut Sheet, Roll Stock,  
Inline Thermoforming**

*Turn to the leader for  
your next sheet line project!*

PROCESSING TECHNOLOGIES, Inc.  
2655 White Oak Circle - Aurora, IL 60502  
Ph: 630.585.5800 | Fx: 630.585.5855  
www.ptiextruders.com



# PRODUCTO

PROGRESS BY DESIGN

Precision  
Thermoform  
Tooling

When it comes to answering your need  
for quality thin gauge thermoform tooling,  
you can't find a better source than  
Producto.

- Complete turnkey service
- Tooling machined and assembled with precision
- Deliveries to suit your schedules
- Mold beds up to 66" x 120"
- Die sets for complex side prepunching and perimeter trim

- Engineering design using the latest CAD systems and programming Technologies
- Gun drilling services available
- Precision 5 axis machining
- Jig ground punches and dies, springs, pins & bushings and a full line of quality accessory items

## Producto Corporation

800 Union Avenue,  
Bridgeport, Ct 06607  
Tel. (203) 367-8675 Fax (203) 368-2597  
http://www.producto.com

These sponsors enable us to publish  
**THERMOFORMING  
QUARTERLY**

**FUTURE MOLD CORP.**

215 S. Webber Street, Farwell, MI 48622  
(989) 588-9948 ♦ (989) 588-6170 Fax

THERMOFORMING TOOLS  
CUP LIP ROLLERS

MIKE OTTO, SALES MANAGER

[www.futuremoldcorp.com](http://www.futuremoldcorp.com)  
motto@futuremoldcorp.com



**SELECT PLASTICS, LLC.**  
EXTRUDED SHEET

7224 Burns St. Metro (817) 595-3804  
Fort Worth, TX 76118 FAX (817) 595-4050  
(877) 501-2530

**Donald H. Hudson** President



Brian Ray  
President

brianr@rayplastics.com

1700 Chablis Avenue  
Ontario, CA 91761

909/390-9906

800/423-7859

FAX 909/390-9896

[www.rayplastics.com](http://www.rayplastics.com)

The Experts in  
Thermoforming

**MODERN  
MACHINERY**

OF BEAVERTON, INC.

CUSTOM CUT SHEET & ROLL FED MACHINERY  
OVEN, CONTROL & INDEX RETROFIT KITS  
PATENTED ADJUSTABLE CLAMP FRAMES

3031 GUERNSEY ROAD, BEAVERTON, MI  
PH: 989-435-9071 FAX: 989-435-3940  
Email: info@modernmachineinc.com



**TPS THERMOFORMER  
PARTS  
SUPPLIERS**

[www.thermoformerparts.com](http://www.thermoformerparts.com)

Thermoformer  
Down?  
Need help fast?  
Call the  
Maintenance Supply  
Pro's at TPS Inc.

Thermoformer Parts Suppliers  
3818 Terry Diane  
Beaverton, MI 48612  
Phone: 800-722-2997  
Fax: 989-435-3825  
Email: tps@ejourney.com

Same day shipping until 4pm EST on In-stock Items

Standex ENGRAVING GROUP

Worldwide Specialists in Textured Rolls,  
Plates, Blanks and Engineered Machinery

**Doug Benton**

Standex Engraving Group  
5901 Lewis Rd.  
Sandston, VA 23150

Ph: 804/236-3065  
Fax: 804/226-3462

These sponsors enable us to publish **THERMOFORMING QUARTERLY**

**Chill Rolls  
Optimized  
for You**

- Design analysis for better heat transfer.
- Extrusion know-how from A to Z.
- Problem-solving, troubleshooting expertise.
- Total in-house production.
- Over 30 years of roll experience.
- Repair and refinishing services.

**XALOY** Call an Xaloy  
roll specialist today!  
Quality 75 Innovation  
YEARS

Heat transfer solutions you can count on

800-897-2830 • 724-656-5600 • E-mail [info@us.xaloy.com](mailto:info@us.xaloy.com) • [www.xaloy.com](http://www.xaloy.com)



**GAS NOT  
ALL IT'S  
FIRED UP  
TO BE?**

Have your gas rebates run out? Are you tired of poor control, lack of uniformity & outrageous replacement costs? Retrofit today with Solar Products ELECTRIC INFRARED heaters.

Custom heater technology – from America's largest supplier of infrared heaters.



**SOLAR PRODUCTS, INC.**  
THE INFRARED HEATER COMPANY

For complete information visit our website at [www.solarproducts.com](http://www.solarproducts.com)

**Call 1-800-616-2601**

**STRENGTH & PRECISION**

**ARES ...  
CNC  
MACHINING  
CENTERS  
FOR  
MACHINING  
PLASTIC AND  
COMPOSITE  
MATERIALS**

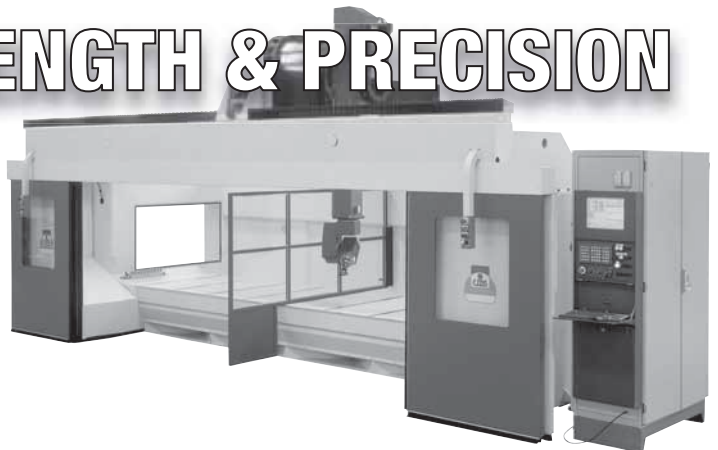

**CMS North America, Inc.**

Grand Rapids, MI  
800.225.5267 Fax: 616.698.9730

[www.cmsna.com](http://www.cmsna.com)  
[www.cms.it](http://www.cms.it)  
[cmssales@cmsna.com](mailto:cmssales@cmsna.com)

# INDEX OF SPONSORS

ADVANCED VENTURES IN TECHNOLOGY, INC. ....	31	FOX MOR GROUP .....	38	LYLE .....	20
ALLEN EXTRUDERS .....	38	FUTURE MOLD CORP. ....	39	MAAC MACHINERY .....	1
AMERICAN CATALYTIC TECHNOLOGIES .....	34	GN PLASTICS .....	32	McCLARIN PLASTICS .....	38
ALTUGLAS INTERNATIONAL .....	25	IRWIN RESEARCH & DEVELOPMENT .....	6	McCONNELL CO. ....	34
BROWN MACHINE .....	35	JRM INTERNATIONAL .....	5	MODERN MACHINERY .....	39
CMS NORTH AMERICA .....	39	KIEFEL TECHNOLOGY .....	18	ONSRUD CUTTER .....	32
CMT MATERIALS, INC. ....	38	KYDEX .....	40	PLASTICS CONCEPTS .....	5
EDWARD D. SEGEN & CO. ....	36	LAND INSTRUMENTS .....	34	PLASTIMACH .....	35
		LANXESS .....	15	PORTAGE CASTING & MOLD, INC. ....	34
				PREMIER MATERIAL CONCEPTS ..	34
				PRIMEX PLASTICS .....	38
				PROCESSING TECHNOLOGIES ..	38
				PRODUCTIVE PLASTICS, INC. ....	34
				PRODUCTO CORPORATION .....	38
				PROFILE PLASTICS .....	34
				PROTHERM .....	15
				RAY PRODUCTS, INC. ....	39
				RAYTEK .....	27
				ROBOTIC PRODUCTION TECHNOLOGY .....	33
				RTP .....	35
				SELECT PLASTICS .....	39
				SENCORP .....	40
				SOLAR PRODUCTS .....	39
				STANDEX ENGRAVING GROUP ..	39
				STOPOL INC. ....	25
				TEMPCO ELECTRIC .....	9
				THERMWOOD CORP. ....	Inside Back Cover
				TOOLING TECHNOLOGY, LLC .....	5
				TPS .....	39
				ULTRA-METRIC TOOL CO. ....	36
				WECO PRODUCTS .....	15
				WELEX, INC. ....	33
				XALOY .....	39
				ZED INDUSTRIES .....	38

These sponsors enable us to publish **THERMOFORMING QUARTERLY**

## SOLVE COST & PERFORMANCE PROBLEMS

- ◆ **Over 40 specialized grades satisfy highest performance to lowest cost applications:**
  - Aircraft
  - Mass transit
  - Building products
  - Weatherable
  - Conductive/ESD
  - Multi-purpose
- ◆ **10 Surface Textures**
- ◆ **Thickness from 0.028" to 0.500"**

- ◆ **Certified Fire Ratings:**
  - UL Std. 94 V-0 and 5V
  - UL 746C for signage
  - FAR 25.853(a) and (d)
  - Class 1/A
  - MVSS 302
  - ASTM E-662/E-162
- ◆ **Broad Color Selection:**
  - 34 Standard colors
  - 2000+ Custom colors
  - Granite patterns
  - Fluorescent colors
  - Woodgrain patterns

Kleerdex Company, LLC  
6685 Low Street  
Bloomsburg, PA 17815 USA  
Tel: 1.800.325.3133  
Fax: 1.800.452.0155  
E-mail: info@kleerdex.com  
www.kydex.com

**KYDEX**<sup>®</sup>  
THERMOPLASTIC SHEET  
ISO 9001:2000 and  
ISO 14001 CERTIFIED



## SENCORP<sup>™</sup> Thermoformers

Special Machines | Clamshell Sealers | Blister Sealers | Laboratory Sealers

Sencorp thermoformers deliver repeatable, quality production parts at high cycle speeds. Available options include closed loop thermal imaging sheet scanning, adjustable shut height, deep draw, quick changeover master tooling and robotic part removal systems. Sencorp thermoformers provide you with a competitive edge over your competition.



We build machines that build business

400 Kidds Hill Road—Hyannis, MA 02601—USA  
P: 508-771-9400 F: 508-790-0002 E: sales@sencorp-inc.com www.sencorp-inc.com