

Thermoforming

QUARTERLY™

A JOURNAL OF THE THERMOFORMING DIVISION OF THE SOCIETY OF PLASTICS ENGINEERS

P. O. Box 471
Lindale, Georgia 30147

CHANGE SERVICE REQUESTED

Non-Profit Org.
U.S. POSTAGE
PAID
SOCIETY OF
PLASTICS
ENGINEERS, INC

FIRST QUARTER 2007, VOLUME 26, NUMBER 1

Thermoforming

QUARTERLY®

A JOURNAL OF THE THERMOFORMING DIVISION OF THE SOCIETY OF PLASTICS ENGINEERS
"WINNER 2003, 2004 & 2005 AWARD OF EXCELLENCE"

Industry Spotlight ...

Universal Plastics: Accepting the Challenge



Our mission is to facilitate the advancement of thermoforming technologies through education, application, promotion and research.

SPE National Executive Director
Susan Oderwald
Direct Line: 203/740-5471
Fax: 203/775-8490
email: Seoderwald@4spe.org

Conference Coordinator
Gwen Mathis
124 Avenue D, SE
Lindale, Georgia 30147-1027
706/235-9298 • Fax: 706/295-4276
email: gmathis224@aol.com

Website: <http://www.4spe.org/communities/divisions/d25.php>
or www.thermoformingdivision.com

2007 - 2009 THERMOFORMING DIVISION ORGANIZATIONAL CHART

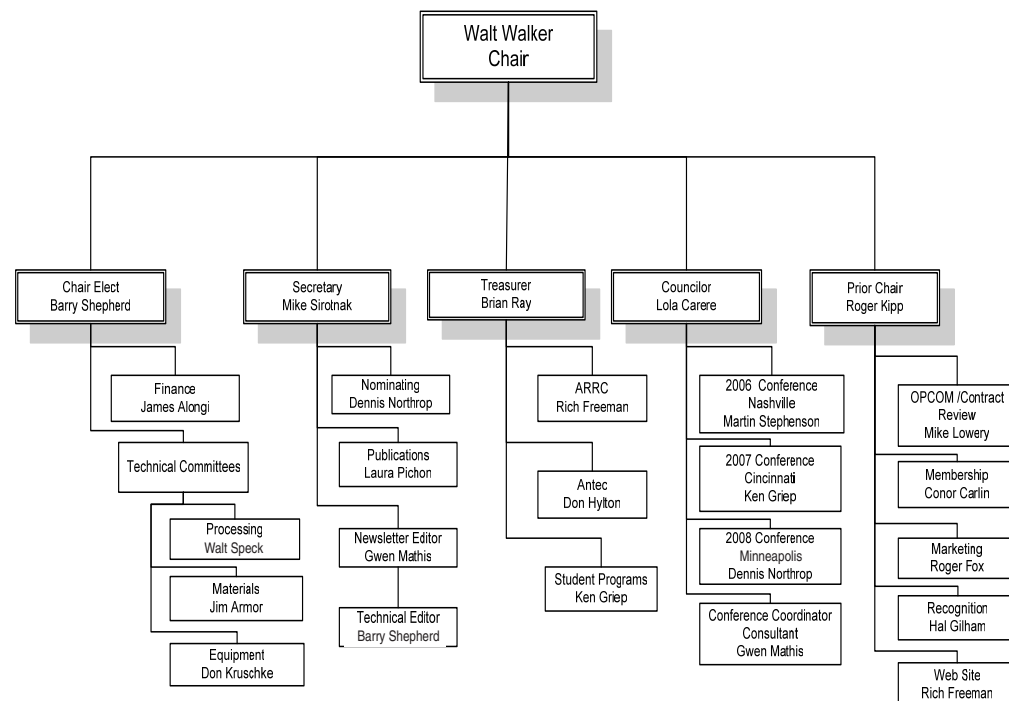

THERMOFORMING DIVISION HOTLINE 800-608-7542 Walt Walker, Chairman, Extension 4401# at Prent Corporation

Executive Committee 2007 - 2009

CHAIR

Walt Walker
Prent Corporation
P. O. Box 471, 2225 Kennedy Road
Janesville, WI 53547-0471
(608) 754-0276 x4410 • Fax (608) 754-2410
wwalker@prent.com

CHAIR ELECT

Barry Shepherd
Shepherd Thermoforming & Packaging, Inc.
5 Abacus Road
Brampton, Ontario L6T 5B7 Canada
(905) 459-4545 x229 • Fax (905) 459-6746
bshep@shepherd.ca

TREASURER

Brian Ray
Ray Products
1700 Chablis Avenue
Ontario, CA 91761
(909) 390-9906 • Fax (909) 390-9984
brianr@rayplastics.com

SECRETARY

Mike Sirotnak
Solar Products
228 Wanaque Avenue
Pompton Lakes, NJ 07442
(973) 248-9370 • Fax (973) 835-7856
msirotnak@solarproducts.com

COUNCILOR WITH TERM ENDING ANTEC 2009

Lola Carere
Thermopro, Inc.
2860 Preston Ridge Lane
Dacula, GA 30019
(770) 339-8744 • Fax (770) 339-4181
lcarere@bellsouth.net

PRIOR CHAIR

Roger Kipp
McClarín Plastics
P. O. Box 486, 15 Industrial Drive
Hanover, PA 17331
(717) 637-2241 x4003 • Fax (717) 637-4811
rkipp@mcclarinplastics.com



Web Site: www.thermoformingdivision.com

Contents

THERMOFORMING[®] QUARTERLY

TECHNICAL SECTION

Spotlight on Industry

Universal Plastics: Accepting the Challenge 8

Comments from the Technical Editor

Barry Shepherd 11

History of Thermoforming, Part 5

The Golden Age of Thermoforming 13

Thermoforming 101:

Process – Cycle Time 19

DIVISION ACTIVITIES

Chairman's Corner Inside Front Cover

Membership 2

New Members 3

Spring Board Meeting Schedule 4

Thermoformer of the Year 2008 Criteria 6

Thermoformer of the Year 2008 Application 7

2007 Parts Competition Announcement 24

Industrial Thermoforming Symposium & Workshop 24

2007 Thermoforming Exhibits for Cincinnati 25

Membership Application 29

Index of Sponsors 32

Board of Directors List Inside Back Cover

These sponsors enable us to publish **THERMOFORMING QUARTERLY**

SOLAR KOTE[®]

Acrylic Capstock and Film

Capstock solutions for thermoformed sheet.

- Outstanding for ABS, PC/ABS, PVC and HIPS
- Weatherable and easy to fabricate
- Excellent gloss control – from flat matte to ultra high gloss
- Chemical-, scratch- and UV-resistant
- Available in metallic, clear or any color

www.solarkote.com

Phone: 215.419.7982

Fax: 215.419.5512

E-mail:

andrew.horvath@altuglasint.com

ALTUGLAS
INTERNATIONAL
ARKEMA GROUP

Altuglas[®] and Solarkote[®] are registered trademarks belonging to Arkema.
© 2005 Arkema Inc. All rights reserved.

A NOTE TO PROSPECTIVE AUTHORS

TFQ is an "equal opportunity" publisher! You will note that we have several categories of technical articles, ranging from the super-high tech (sometimes with equations!), to industry practice articles, to book reviews, how to articles, tutorial articles, and so on. Got an article that doesn't seem to fit in these categories? Send it to Barry Shepherd, Technical Editor, anyway. He'll fit it in! He promises. [By the way, if you are submitting an article, Barry would appreciate it on CD-ROM in DOC format. All graphs and photos should be black and white and of sufficient size and contrast to be scannable. Thanks.]

THERMOFORMING[®] QUARTERLY

A JOURNAL PUBLISHED EACH CALENDAR
QUARTER BY THE THERMOFORMING DIVISION
OF THE SOCIETY OF PLASTICS ENGINEERS

Editor

Gwen Mathis

(706) 235-9298 • Fax (706) 295-4276

gmathis224@aol.com

Technical Editor

Barry Shepherd

Shepherd Thermoforming &

Packaging, Inc.

5 Abacus Road

Brampton, Ontario L6T 5B7

CANADA

(905) 459-4545 Ext. 229

Fax (905) 459-6746

bshep@shepherd.ca

Sponsorships

Laura Pichon

(847) 829-8124

Fax (815) 678-4248

lpichon@extechplastics.com

Thermoforming Quarterly[®] is published four times annually as an informational and educational bulletin to the members of the Society of Plastics Engineers, Thermoforming Division, and the thermoforming industry. The name, "Thermoforming Quarterly[®]" and its logotype, are registered trademarks of the Thermoforming Division of the Society of Plastics Engineers, Inc. No part of this publication may be reproduced in any form or by any means without prior written permission of the publisher, copyright holder. Opinions of the authors are their own, and the publishers cannot be held responsible for opinions or representations of any unsolicited material. Printed in the U.S.A.

Thermoforming Quarterly[®] is registered in the US Patent and Trademark Office (Registration no. 2,229,747).

MEMBERSHIP

BY CONOR CARLIN, MEMBERSHIP CHAIRMAN

Out With the Old, In With the New

As we look back on 2006, we have an opportunity to reflect on the past twelve months. In talking to thermoformers around the country, all indicators show that our industry is enjoying robust growth. It appears that the changes made during the lean years at the start of the decade have paid off. Profits are up and reinvestment in the sector is underway.

Plastics industry publications usually feature dire news about plant closings or toolmakers going out of business, mainly in the large and diversified injection molding sector. Our segment, however, continues to grow as companies increase market share and compete more effectively with alternative techniques. Bolstered by new technologies, especially in the heavy-gauge business, thermoformers are making the investments needed to keep pace with today's changing market.



Signs of encouragement and growth are all around us. From new package designs on store shelves to innovative products in diversified markets, thermoforming is clearly an integral part of the consumer culture. In fact, several parts that were highlighted at the Nashville Parts Competition can now be seen on television commercials.

The fact that thermoformed products are so important in today's economy really highlights the need to stay informed. New developments in materials, new machine designs and new tooling techniques all combine to improve the quality of the

goods and services provided by the thermoforming community. Our division plays a crucial role in that it provides an arena in which many of these evolutions can be seen and understood before they hit the market.

2007 is shaping up to be a great year. The SPE board is already building a strong technical program for the Cincinnati Conference. If you have suggestions or comments on something you would like to see, please contact us. Also, please remember to sponsor a new member this coming year. This organization derives strength from its membership and your participation is paramount to our success. ■

Questions?

Comments?

Contact me at

conorc@stopol.com

WELCOME, NEW MEMBERS!

Maxime Boissy - 254014

Camoplast Inc Fibrex
Division
3155 Boulevard Des
Entreprises
Terrebonne, QC J6X 4J9
Canada

David J. Clark - 259490

Par-Pak Europe Ltd
37-39 Burners Lane
Kiln Farm
Milton Keynes, Bucks
MK11 3HA
United Kingdom

**Charles H. Crowell -
221501**

Ray Products
1700 Chablis Avenue
Ontario, CA 91761

Nicolas S. Cruz - 259565

3035 Stevens Ave
Parsons, KS 67357

Martin Gibler - 224830

Stress Engineering
5380 Courseview Drive
Mason, OH 45040

**Jeffrey A. Murray -
228340**

82 Gibson St
North East, PA 16428

Dan Rossi - 259548

Gros Plastics Recruiters
13 Ridge Street
Hackettstown, NJ 07840

Eric Fiset - 259260

Plastique Tilton Inc
175 Rue Des Grands -
Lacs
St Augustin De
Desmaures, QC G3A 2KB
Canada

**Fred J. Giordano -
259415**

W L Gore & Associates
401 Airport Rd
Elkton, MD 21921

**Jason A. Jernigan -
255893**

ImagePoint Inc
7430 Industrial Rd
Florence, KY 41042

**Stephen B. Konrad -
259273**

Indepak
2136 NE 194th
Portland, OR 97230

Tricia McKnight - 247193

Society of Plastics
Engineers
14 Fairfield Drive
Brookfield, CT 06804

**Francisco Molina -
259441**

Thermo King Arecibo PR
Call Box 144060
Arecibo, PR 00614-4060

Wayne R. Smith - 242364

Fabri-Kal Corporation
600 Plastics Place
Kalamazoo, MI 49001

Bill Sparling - 259299

Power Packaging
101-917 Cliveden Ave
Delta, BR V3M 5R6
Canada

**David R. Zuehlke -
259311**

Sub-Zero Freezer
Company
4717 Hammersley Road
Madison, WI 53711

WHY JOIN?

It has never been more important to be a member of your professional society than now, in the current climate of change and volatility in the plastics industry. Now, more than ever, the information you access and the personal networks you create can and will directly impact your future and your career.

Active membership in SPE:

- **keeps you current**
- **keeps you informed**
- **keeps you connected**

The question really isn't "why join?" but ...

WHY NOT?

**THERMOFORMING DIVISION
SPRING BOARD
MEETING SCHEDULE**

**May 16th - 20th, 2007
Flamingo Las Vegas
Las Vegas, Nevada**

****Rooms have been reserved in our block starting Tuesday, 5/15/07, departing on Sunday, 5/20/07. These rooms are limited, so FIRST COME, FIRST SERVE:**

FOR RESERVATIONS, CALL: 1-800-835-5686 – REQUEST SPE ROOM RATE OF \$119.00 OR GROUP CODE SFSPE7.

Tuesday, May 15th, 2007

Executive Committee Arrives

Wednesday, May 16th, 2007

- 7:30 – 8:30 am – Breakfast – Executive Committee, Conference Suite A
- 8:30 am – 5:00 pm – Executive Committee Meeting, Conference Suite A
- 12:00 – 1:00 p.m. – Lunch – Executive Committee, Conference Suite A
- 2:00 – 3:00 pm – Finance Committee Chairman, Conference Suite A
- 4:00 – 5:00 pm – Technical Chairs meet with Executive Committee, Conference Suite A

Thursday, May 17th, 2007

- 8:30 – 10:30 am – Materials Committee Breakfast, Conference Suite A
- 8:30 – 10:30 am – Processing Committee Breakfast, Conference Suite B
- 8:30 – 10:30 am – Processing Committee Breakfast, Conference Suite C
- 10:30 – 11:15 am – AARC Committee, Carson City 1
- 11:15 am – 12:00 pm – Web Site Committee, Carson City 1
- 12:00 pm – 1:30 pm – LUNCH ON YOUR OWN**
- 1:30 – 2:30 pm – Student Programs, Carson City 1
- 2:30 – 3:00 pm – Recognition, Carson City 1
- 2:30 – 3:30 pm – 2007 Conference Committee, Carson City 1
- 3:30 – 4:15 pm – Marketing Committee, Carson City 1
- 4:00 – 5:00 pm – Membership Committee, Carson City 1

Friday, May 18th, 2007

- 7:30 – 8:30 am – Breakfast – Board of Directors, Laughlin III
- 8:30 am – 12:00 pm – Board of Directors' Meeting, Laughlin III
- 12:00 – 1:00 pm – Lunch – Board of Directors, Laughlin III
- AFTERNOON ON YOUR OWN**
- 6:00 – 7:00 pm – Hosted Cocktail Party
- DINNER ON YOUR OWN**

Saturday, May 19th, 2007

DAY ON YOUR OWN

Sunday, May 20th, 2007

Depart

These sponsors enable us to publish **THERMOFORMING QUARTERLY**

Ceramic Infrared E-Mitters and Panels

E-Mitter[®] **METAMORPHING** Color Change™ provides a visible indication of operation
Stocked in a variety of Standard Colors, Sizes and Electrical Ratings

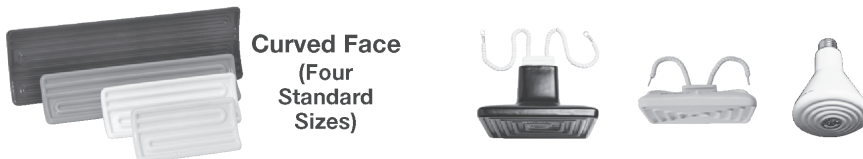

Curved Face
(Four Standard Sizes)

TEMPCO can manufacture custom configured panels to accommodate your process



KTE Series High Intensity Quartz Mini-Tube Infrared E-Mitters

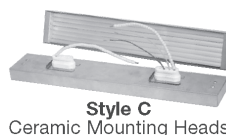

Style C
Ceramic Mounting Heads



Style S
Mounting Studs

Universal 2000[®] Tubular Radiant Heater



Vitreous Silica Quartz Tube



Complete Your Thermal Loop System with
Tempco's family of **TEC**™ Temperature Controllers

Call today for your free copy of our 864 page
Catalog of Electric Heaters, Temperature Controls and Sensors



TEMPCO Electric Heater Corporation
607 N. Central Avenue • Wood Dale, IL 60191
(630) 350-2252 • Toll Free (800) 323-6859
Fax (630) 350-0232 • E-mail: info@tempco.com

Product Inventory available for Viewing and Selection @ tempco.com

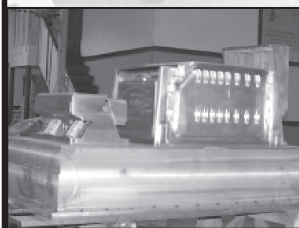
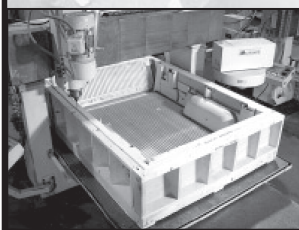

Tooling Technology, LLC

A TOOLING TECH GROUP COMPANY

100 Enterprise Drive • Ft. Loramie, OH 45845
tel: (937) 295-3672 • fax: (937) 295-3677
Website: toolingtechgroup.com

- Vacuum forming (twin sheet, single sheet, pressure form)
- Rotational molding
- Blow molding
- Router Fixtures
- Compression molding
- E.P.S. molding
- Deep Hole Gundrilling
- Rubber molding
- Polyurethane molding
- Carpet stamping dies
- Metal stamping dies
- Vinyl forming
- Pulp molding
- Models & patterns
- Check Fixtures

**Full in House Design, CNC Machining,
Aluminum Foundry, & Fabrication Services**

Need help with your technical school or college expenses?

If you or someone you know is working towards a career in the plastic industry, let the SPE Thermoforming Division help support those education goals.

Our mission is to facilitate the advancement of thermoforming technologies through education, application, promotion, and research. Within this past year alone, our organization has awarded multiple scholarships! Get involved and take advantage of available support from your plastic industry!

Start by completing the application forms at www.thermoformingdivision.com or at www.4spe.com. The deadline for applications is January 15th, 2008. ■



Thermo Forming

Division

These sponsors enable us to publish **THERMOFORMING QUARTERLY**



MAKA ROUTERS

First to Build 5 Axis CNC Routers...

First to offer Broad Line of 5 Axis CNC Routers

First in Accuracy and Speed

First in Service and Spare Parts

First in Software, Training and Support

... and We're Still First

JRM International, Inc.

TOLL FREE: 800-676-4755

5701 Industrial Avenue • Rockford, IL 61111 • Fax: 815-282-9150
E-Mail: jrmsales@jrminternational.com • www.jrminternational.com



Save time and money on your thermoform molds

When you use Alcoa 6013-T651 Power Plate™ aluminum versus 6061, you'll experience:

- 30% to 45% higher CNC Speeds and Feeds
- Up to 75% less burrs
- Up to 15% improved "as machined" surface finish
- Higher strength and surface hardness
- Enhanced gun drilling and other deep hole machining

We will work with your machine shops so you can realize the time and cost savings that will help you move ahead of the competition.



Or contact John Perryman at (248) 233-5725,
e-mail: jperryman@tkmna.thyssenkrupp.com

6013-T651 Power Plate™ is distributed by:

ThyssenKrupp Materials NA

Copper and Brass Sales Division

A ThyssenKrupp Services company

ThyssenKrupp Materials NA, Inc. — AIN Plastics, Copper and Brass Sales, Ken-Mac Metals, TMX Aerospace,
ThyssenKrupp Steel Services, ThyssenKrupp Hearn, TKX Logistics



ThyssenKrupp

THERMOFORMER OF THE YEAR

CRITERIA FOR 2008

Every year The SPE Thermoforming Division selects a individual who has made a outstanding contribution to our industry and awards them the Thermoformer of the Year award.

The award in the past has gone to industry pioneers like Bo Stratton and Sam Shapiro, who were among the first to found thermoforming companies and develop our industry. We have included machine designers and builders Gaylord Brown and Robert Butzko and toolmaker John Greip, individuals who helped develop the equipment and mold ideas we all use today. We have also honored engineers like Lew Blanchard and Stephen Sweig, who developed and patented new methods of thermoforming. Additionally, we have featured educators like Bill McConnell, Jim Throne and Herman R. Osmer, who have both spread the word and were key figures in founding the Thermoforming Division.

We're looking for more individuals like these and we're turning to the Thermoforming community to find them. Requirements would include several of the following:

- Founder or Owner of a Thermoforming Company
- Patents Developed
- Is currently active in or recently retired from the Thermoforming Industry
- Is a Processor – or capable of processing
- Someone who developed new markets for or started a new trend or style of Thermoforming
- Significant contributions to the work of the Thermoforming Division Board of Directors

➤ Has made a significant educational contribution to the Thermoforming Industry.

If you would like to bring someone who meets some or all of these requirements to the attention of the Thermoforming Division, please fill out a nomination form and a one-to-two-page biography and forward it to:

Thermoforming Division Awards Committee

% Productive Plastics, Inc.

Hal Gilham

103 West Park Drive

Mt. Laurel, NJ 08045

Tel: 856-778-4300

Fax: 856-234-3310

Email:

halg@productiveplastics.com

You can also find the form and see all the past winners at www.thermoformingdivision.com in the Thermoformer of the Year section.

You can submit nominations and bios at any time but please keep in mind our deadline for submissions is no later than December 1st of each year, so nominations received after that time will go forward to the next year.

These sponsors enable us to publish **THERMOFORMING QUARTERLY**



THE NEW MAAC!

- *Larger Mainframes
- *All Encoder Positioning
- *Bigger Motors
- *Adjustable Clampframes
- *Faster Drives
- *Guaranteed Cycle Times

Leader in Twin-Sheet Pressure Forming Technology!

- Single Stations
- Double Enders
- Three-Station Rotaries
- Four-Station Rotaries
- Oven-Over
- Custom Machines



4-Week Deliveries!

WWW.MAACMACHINERY.COM
590 Tower Blvd, Carol Stream, IL 60188, Tel: (630) 665-1700

Thermoformers of the Year ...

1982

William K. McConnell, Jr.
McConnell Company

1983

E. Bowman Stratton, Jr.
Auto-Vac Corp.

1984

Gaylord Brown, Brown Machine

1985

Robert L. Butzko
Thermtrol Corp.

1986

George Wiss, Plastofilm Industries

1987

Dr. Herman R. Osmers
Educator & Consultant

1988

Robert Kittridge
Fabri-Kal Corporation

1989

Jack Pregont, Prent Corporation

1990

Ripley W. Gage, Gage Industries

1991

Stanley Rosen
Mold Systems Corp.

1992

Samuel Shapiro
Maryland Cup
Sweetheart Plastics

1993

John Grundy, Profile Plastics

1994

R. Lewis Blanchard
Dow Chemical

1995

James L. Blin, Triangle Plastics

1996

John Griep
Portage Casting & Mold

1997

John S. Hopple, Hopple Plastics

1998

Lyle Shuert, Shuert Industries

1999

Art Buckel, McConnell Company

2000

Dr. James Throne
Sherwood Technologies

2001

Joseph Pregont, Prent Corp.

2002

Stephen Sweig, Profile Plastics

2003

William Benjamin
Benjamin Mfg.

2004

Steve Hasselbach, CMI Plastics

2005

Manfred Jacob
Jacob Kunststofftechnik

2006

Paul Alongi, MAAC Machinery

THERMOFORMER OF THE YEAR 2008

Presented at the September 2008 Thermoforming Conference in Minneapolis, MN

The Awards Committee is now accepting nominations for the 2008 THERMOFORMER OF THE YEAR. Please help us by identifying worthy candidates. This prestigious honor will be awarded to a member of our industry that has made a significant contribution to the Thermoforming Industry in a Technical, Educational, or Management aspect of Thermoforming. Nominees will be evaluated and voted on by the Thermoforming Board of Directors at the Winter 2008 meeting. The deadline for submitting nominations is December 1st, 2007. Please complete the form below and include all biographical information.

Person Nominated: _____ Title: _____

Firm or Institution: _____

Street Address: _____ City, State, Zip: _____

Telephone: _____ Fax: _____ E-mail: _____

Biographical Information:

- Nominee's Experience in the Thermoforming Industry.
- Nominee's Education (include degrees, year granted, name and location of university)
- Prior corporate or academic affiliations (include company and/or institutions, title, and approximate dates of affiliations)
- Professional society affiliations
- Professional honors and awards.
- Publications and patents (please attach list).
- Evaluation of the effect of this individual's achievement on technology and progress of the plastics industry. (To support nomination, attach substantial documentation of these achievements.)
- Other significant accomplishments in the field of plastics.
- Professional achievements in plastics (summarize specific achievements upon which this nomination is based on a separate sheet).

Individual Submitting Nomination: _____ Title: _____

Firm or Institution: _____

Address: _____ City, State, Zip: _____

Phone: _____ Fax: _____ E-mail: _____

Signature: _____ Date: _____

(ALL NOMINATIONS MUST BE SIGNED)

Please submit all nominations to: Hal Gilham,
Productive Plastics, 103 West Park Drive
Mt. Laurel, New Jersey 08045

THERMOFORMING AT UNIVERSAL PLASTICS: ACCEPTING THE CHALLENGE MEANT ADDING THIN-GAUGE PROCESSING

BY JOE PETERS, UNIVERSAL PLASTICS

This article space in the *Thermoforming Quarterly* alternates each year between roll-fed formers and cut-sheet formers. The Thermoforming Division Conference each year divides its program the same way between thin-gauge and heavy-gauge. At Universal Plastics they certainly get their money's worth out of those articles and conferences because they employ both processes in their plant in Holyoke, Massachusetts.

In order to satisfy as many customer needs as possible, Universal added roll-fed thermoforming several years ago.

The company had its beginning in 1966 when James Peters took his 12

years of experience and built his first two heavy-gauge forming machines from the ground up and started forming tote boxes for many of the heavy manufacturers in New England in the sixties. The business evolved through the years and with the advent of the computer age and the development of the Route 128 computer corridor near Boston with its big names from Digital, Raytheon and Data General to Wang, Compugraphics, Polaroid and Prime. In those days CRT housings and bezels, keyboard enclosures and circuit board trays

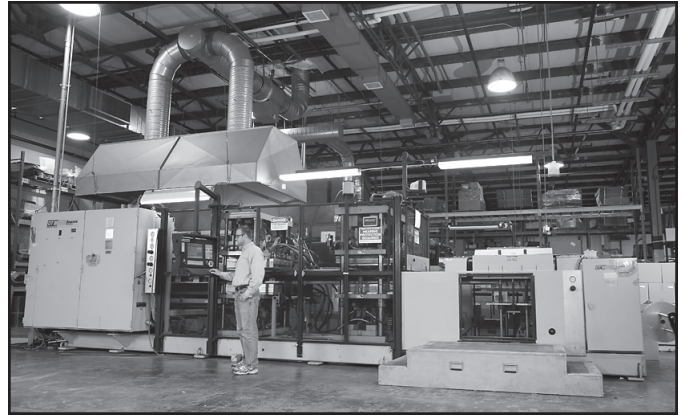

Universal has adopted the motto "We Accept the Challenge" and living up to that motto has lead them to making the cooling ducts for the guidance system for the space shuttle, kayaks from recycled detergent bottles, the bows for the super secret (not any longer) submarine used by the Navy Seals and the bus stop signs for New York City. The company has a reputation for getting the job done and has some great employees who make it happen.

represented most of their output. These were days before CNC routers and all of the close tolerance cutouts and trimming were done on elaborate routing fixtures using templates and guide bushings in

the router plate. They learned enough about repairing router fixtures from those years that when they saw their first Thermwood CNC router in the early 1980's – they bought it on the spot. Looking back now it's amazing how almost none of those big names in the computer industry are even around today. It's not surprising that Universal has had to adapt to its changing market.

Universal has adopted the motto "We Accept the Challenge" and living up to that motto has lead them to making the cooling ducts for the guidance



system for the space shuttle, kayaks from recycled detergent bottles, the bows for the super secret (not any longer) submarine used by the Navy Seals and the bus stop signs for New York City. The company has a reputation for getting the job done and has some great employees who make it happen.

As a custom manufacturer, you have to adapt and Universal saw opportunity in the jewelry, cosmetics and POP fields for packages, trays and displays. The journey into thin-gauge thermoforming began with a salesman bringing in a shallow thin-gauge formed cup that was die cut with a small flange. The customer had a number of labor steps to transform the cup into a satin-covered stand for a bracelet in an injection molded box. This customer bought 3 million of

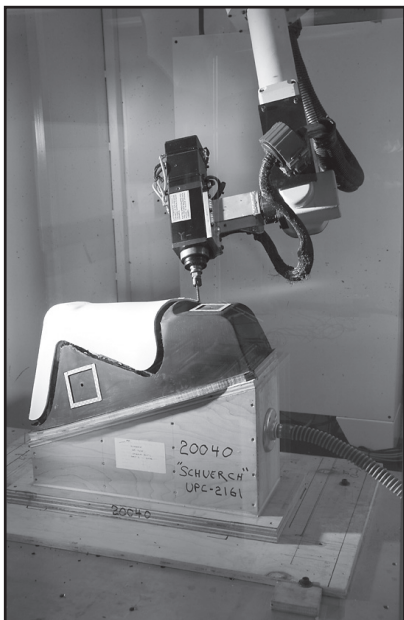

these a year! Universal was accustomed to 250- and 500-piece orders so this number got their attention. After much thought the designers were able to propose an idea that eliminated many of the labor operations. The problem was they would be forming the part on a 64 impression mold on a heavy-gauge machine at rate of about 25 blanks per hour. At this rate it would take 3 people working full time to make 3 million pieces a year.

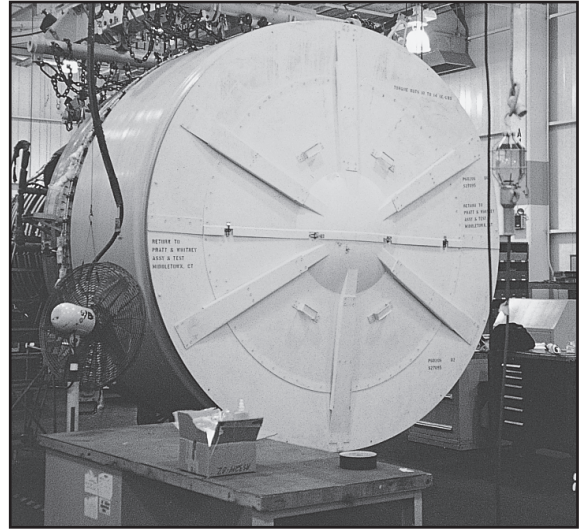

They decided to buy a small roll-fed machine and after setup and some training, one person could run a year's worth of product in 6 months. Now they had to keep the machine busy the other six months. New business soon appeared and they now have two Sencorp 2500 in-line formers to complement the heavy-gauge business consisting of 12 vacuum and pressure forming machines which include two rotaries and twin-sheet capability. The largest press is a double-ender boasting a 6' x 16' capacity.

Currently thin-gauge work represents about 20% of sales and has been growing steadily. Many similarities exist but there are also some dramatic differences between the two processes. Most dramatic is the competitiveness of the thin-gauge work. With thin-gauge, jobs are won and lost by fractions of pennies per part. If you are \$0.002 too

(continued on next page)

(continued from previous page)



high – sorry!! In thin-gauge, inches add up quick. Estimating a job that ends up with 1/2" longer index than planned can have a dramatic effect on the bottom line – not to mention the rolls of material that you can end up short at the end of a job.

An area of similarity that has become more true in both areas of the business is the need to be in sync with your customer's needs. Universal finds they are working harder and harder to run ahead of their customers. They have to keep more inventory on hand, whether it is raw material or finished goods. They also have worked to reduce set-up times and reduce turnaround time. They use 3D CAD and are able to machine some molds in-house, especially when customers require shorter than normal deliveries (sound familiar?).

While this journey for Universal Plastics was into the world of "Thin," they still find that they are immersed in the world of "Lean." The year 2007 will be an especially taxing one for the 85 employees at Universal Plastics as they will all be more intensely trained in "lean manufacturing." The company was treated to a taste of lean manufacturing through a training grant from the State of Massachusetts in 2002 which gave them exposure to many of the benefits.

In 2003 the factory moved out of a late 19th century mill building where they occupied 100,000 sq. ft. on three floors into a new facility with 75,000

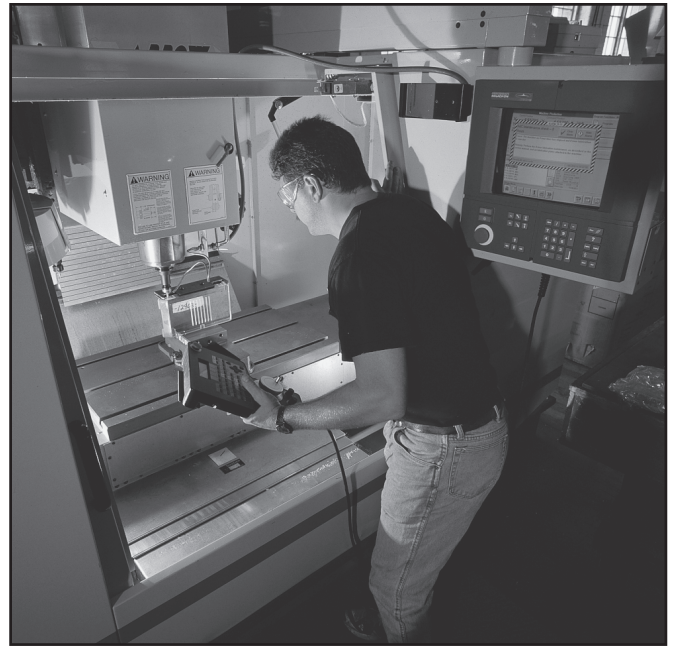

sq. ft. on one floor. It's taken a couple of years to get settled in but now they are ready to take on "lean." The next time we read about Universal Plastics perhaps we will learn how they became "lean" as well as "thin." ■

Experience the **Magic**
When Two Great Events Become One ...

May 6-10, 2007
Duke Energy Center
Cincinnati, Ohio

PLASTICS Encounter at
Conferences ▲ Networking ▲ Exhibits

ANTEC 2007
Annual Technical Conference - Cincinnati, Ohio May 6-10

The newest partnership in plastics means
more conferences ... more exhibits ... and more networking!
Make plans NOW to visit the largest
plastics-only event in the United States next year.
It's simply magical!

Visit www.antec.ws or contact SPE's Event Management Department at antec@4spe.org
www.4spe.org/productfocus/

COMMENTS FROM THE TECHNICAL EDITOR

BY BARRY SHEPHERD

Newsletter History

The Thermoforming Division has been publishing this newsletter for over 30 years. Bill McConnell, our longest serving Board member, started it in the early 70's and Gwen Mathis, our Division Coordinator, took over as Editor in 1981. Dr. Jim Throne took on the job of Technical Editor in 1998 until this year, a period in which we saw the *Quarterly* develop into the award-winning publication that we know today.

Jim Throne provided technical content for more than 32 volumes including 140 technical articles and 26 book reviews. His "Thermoforming 101" collection of thermoforming basics is a must for every plant library. I am excited about continuing to write these articles from a slightly different perspective. Jim has decided to move on to other things and I have taken on the daunting task of carrying on as the Technical Editor for this *Quarterly*. Gwen Mathis remains as Editor, a job which she has enjoyed for over 25 years and for which I am most thankful.

The *Thermoforming Quarterly* has not won all these awards over all the other SPE newsletters without a great deal of hard work and dedication. Meeting time lines, finding articles, copywriting and proofreading for a publication that sometimes consists of over 40 pages takes effort and the responsibility for bringing it all together 4 times a year falls on Gwen's shoulders.

Content and Format

As for the content of future technical articles, I want to repeat what I told the Board when I accepted this challenge. Thermoforming has been my life and my family's life for 22 years. Our Chairman, Walt Walker, sensed the passion that I have for this industry when he agreed to let me take it on and I hope that this passion will become evident in the technical content of future *Quarterly's*.

I would like to continue providing articles that contain new and useful information for the most knowledgeable readers but I also hope to add my own flavor to these articles that will connect the theory to a real practical application. My experience with building our custom thermoforming business has exposed me to many technical problems so I hope to be able to contribute some personal comment. Having said this I am aware that there is a great deal of innovative work going on in operations and institutions throughout the world by individuals who are dedicated to a specific product or process related to thermoforming. These operations have money, time and highly skilled people that are doing things that will help take our industry to new levels. Therefore I will endeavor to solicit opinions from others on articles that contain information beyond my scope of expertise.

I see no reason to alter the format to any great extent. I do hope to maintain the Lead Articles, Industry Practice articles and Thermoforming 101 articles. Dr. Throne has reviewed a lot of books over the years and I am not sure there are any more that could be considered Thermoforming related. However, I would welcome the opportunity to comment on any new industry related publications.

Some Personal Goals

As a personal project, I want to produce "A Reference Guide to Advanced Thermoforming" using the technical articles that have appeared in this *Quarterly* over the past 10 years. It will take some time to categorize the information to allow quick reference by industry engineers and practitioners to help solve problems or improve quality or maximize efficiency. As new articles are published they will be added to the Guide. It will be available to SPE members in the electronic format via the Division website.

My hope is to expand the "Industry Practice" segments to look at how current trends and issues are affecting the way we run our thermoforming companies. For example, how will Walmart's goal to reduce packaging 5% by 2010 affect designers and producers of thermoformed packaging? Also current trends to global sourcing and the depressed state of North American automotive manufacturing have direct affects on our industry. On the surface these issues would appear to have a negative impact on our industry; however, as thermoformers, we are known for our ability to adapt to change quicker than other processes. If we are aware of the issues and open our minds to our options we can create opportunities for our companies.

Finally, I will be working to find ways to combine our efforts here in North America with those in Europe to benefit our industry on a more global stage. This is a personal goal but I see several indicators that suggest we must do this. The SPE magazine *Plastic Engineering* is combining with its European counterpart starting in January 2007. The North American and European Thermoforming Divisions now take part in each other's conference and of course globalization in general is making it necessary for all of us to be aware of competitive pressures in other countries. The *Quarterly* and the European Thermoforming newsletter must collaborate to become the vehicle for sharing ideas across the Atlantic.

It is with some apprehension that I take on this responsibility after so many years in the hands of such an industry authority; however, I look forward to it with anticipation. I am proud of the *Quarterly* and eager to help Gwen and the Board maintain its award-winning record. ■

MARK YOUR CALENDAR!!!

The Thermoforming Board of Directors has taken your advise from completing the surveys and beginning in 2008 we will be going back to our old dates –

DATES:

Saturday,
September 20th, 2008
thru
Tuesday,
September 23rd,
2008

MINNEAPOLIS
CONVENTION CENTER

HEADQUARTER HOTEL:
MINNEAPOLIS HILTON
& TOWERS

2008 Chairman:
Dennis Northrop
Avery Dennison
Performance Films

Cut Sheet Chairman:
Jim Armor
Armor & Associates

Roll Fed Chairman:
Phil Barhouse
Creative Forming

These sponsors enable us to publish **THERMOFORMING QUARTERLY**

Plastics for the Thermoforming Industry

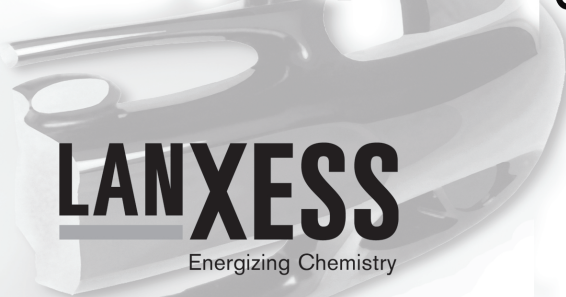

Lustran® ABS
Lustran® SAN
Lustran® Soft Touch
Centrex® ASA/AES
Centrex® Soft Touch

For information call
1-800-LANXESS
www.US.LANXESS.com

IN THE WORLD OF THERMOFORMING, *We're Changing the Rules!*





Quality built, heavy duty machines, systems, components and accessories
Advanced features -- faster, more cost-effective and longer lasting
We not only meet, but often exceed, your production requirements
Experience, reliability, integrity and follow through
Designed for the application, your application
Enhanced control over quality, speed
Long lasting with quick payback
Highly competitive pricing
Unparalleled service
On time deliveries
Energy efficient
Full Training



ADVANCED VENTURES IN TECHNOLOGY, INC.
3870 West Highway M-61, Gladwin, MI 48624
Tel: 989-246-0445 • Fax: 989-246-0465

Web: www.adv-ven-tech.com • E-mail: sales@adv-ven-tech.com

**Manufacturers of the World's Largest
Thermoforming Machine!**

Ceramic Quartz Reflectors	  4' x 6' Ceramic Infrared Oven As shown: Operating 5 zones	Full Line Infrared Supplier Ovens / Controls Replacement Parts  Hetronik HC300 Used to control oven pictured at left.	Weco International, Inc. 841 Tacoma Court Clio, MI 48420 (810) 686-7221 Phone  HMI offers optimal viewing and feedback during run time	High Temp Wire Tungsten Halogen
	<p>Increased:</p> <ul style="list-style-type: none"> ✓ Part Quality ✓ Parts per hour ✓ Savings ✓ Efficiency 	<p>Reduced:</p> <ul style="list-style-type: none"> ✓ Energy costs by up to 40% ✓ Cycle / Setup time ✓ Panel space ✓ Scrap material 		
www.wecointernational.com				

The Golden Age of Thermoforming

BY STANLEY R. ROSEN, PLASTIMACH CORPORATION, LAS VEGAS, NEVADA

The **First National Plastics Exposition** was held at the Grand Central Palace, New York City, from April 22nd through the 27th, 1946 in conjunction with the S.P.I. Spring Conference with a record assembly of 83,100 attendees. Much vitality and optimism flowed from those attending the show which was evident from their enthusiastic faces in this photo (Fig. 3-1.) World War II was



Fig. 3-1. First NPE Plastics show in New York City, 1946.

over and many in the crowd were discharged veterans anxious to enter and embark on a new career. Visitors to the show were intrigued by seeing operating equipment, displays of new products and processes created from the plastics resins. Critics of the show complained that more than half of the visitors were not from the “trade” but were only “interested spectators.” How shortsighted it was to throw cold water at prospective plastics industry participants!

Many in attendance were the children of the depression era whose parents’ dreams and ambitions were quashed during those harsh economic times. This new generation of prospective businessmen, technicians and

Ed. Note I: The philosopher Santana said, “Those who cannot remember the past are destined to repeat it.” Stan Rosen, our Thermoformer of the Year in 1991, is undertaking this project to document the industry starting with early developments in the 1930’s. His first article (Part I) appeared in Volume 24, Issue #3. This is the fifth in his series entitled “The Golden Age of Thermoforming,” the second half of which will appear in the next Quarterly issue.

engineers with confidence in themselves and the economy visualized a bright future. Assistance came from Congress with the passage of the GI Bill of Rights which covered all of the expenses of any veteran interested in pursuing a career as a technician or attaining a university degree (which included this grateful author). A pool of educated and confident entrepreneurs was created at the same time evolving plastic processes permitted many entry points into the industry.

Injection molding in 1946 was the leading process of choice in which resin was converted into a saleable product. Equipment and molds for injection molding are expensive and the lead time for their procurement is quite lengthy. The high cost was amortized for large quantities of items, but smaller amounts often were priced-out by metallic alternatives. Large injection molded parts require high tonnage presses with huge area platens which limited their adoption for big components. Unfortunately, the cure for this dilemma of producing small quantities of large parts was soon heralded as “**Vacuum Forming – the poor man’s injection molding.**”

The deceptive slogan and attitude was further conveyed to the design of equipment and molds which emphasized cost rather than improving existing technology. A low dollar price was highlighted in the machinery brochures and press releases. Component suppliers of radiant heaters and vacuum pumps offered free machine drawings to “*do it yourself vacuum forming machine builders*” (Fig. 3-2). This mindset also permeated

Build Your Own
VACUUM FORMER

—

We Will Supply
RADIANT HEATERS
and **CONTROLS**

- With each order, we will furnish detailed drawings and specifications with which you can build your own VACUUM FORMER or DRAPE FORMER.
- Our RADIANT HEATERS have highest density—with concentrated heat around the edges; temperatures to 800° F.—High efficiency—Low maintenance—Prompt deliveries.

Manufactured by
RADIANT HEAT, Inc. 511 Westminister Street
Providence 3, Rhode Island
Telephone: DEster 1-4500

Fig. 3-2. Receive a set of free drawings to build a vacuum former when purchasing a heater, 1954.

(continued on next page)

(continued from previous page)

early marketing tactics and was used to garner thermoforming orders which often resulted in inconsistent part quality and disappointed customers.

At the Packaging Institute Annual Forum October 1954 in New York City, C. W. Harper of retailer Sears Roebuck blasted the poor quality and reliability of his thermoforming supplier's performance. His kindest remarks included comments concerning peddling of inferior products, charging what the market would bear and that unqualified people were crowding to get into a good thing. This disappointed purchasing agent was the largest thermoforming buyer of his time so these arguments had the power to make the industry sit up and take notice. Eventually the thermoformers modified their sales strategies and sold their strengths- rapid tool scheduling and tightened control of the process. Product designers were then induced to accept the physical limitations of designing a thermoforming part and to circumvent these restraints.

Thermoformed components produced earlier than 1950 were formed on proprietary machinery as no commercial equipment was available for sale. These pioneering thermoforming firms had differing objectives and had to develop equipment that was specific to their own needs.

Gustave W. Borkland, an inventor and founder of Borkland Laboratories, Marion, Indiana, filed for his first plastic sheet forming patent in 1941 and was awarded a number of other vacuum forming patents during the 1940s. He produced and formed parts using both mechanical deep drawing methods as well as manufacturing his advertised "*Suction forming machines*" (Fig. 3-3). This equipment was originally available by license only, with none being sold outright until competing com-

mercial vacuum forming machinery caused a change in his policy.

Plaxall Corp. (Div. Design Center), founded by **Louis Pfohl**, utilized the experience gained from the design of his roll fed mechanical deep drawing equipment (1940s) to develop inline pressure thermoforming and trimming machines in 1953 (Fig. 3-4). It is surpris-

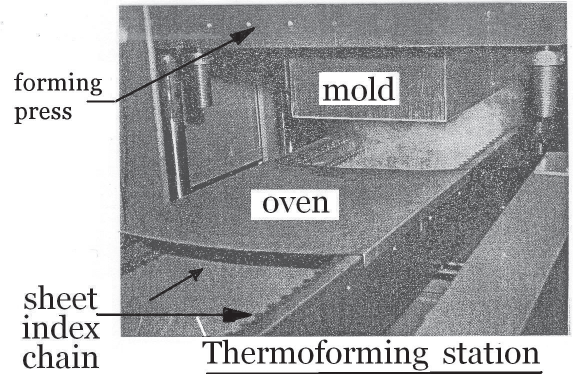

Thermoforming station

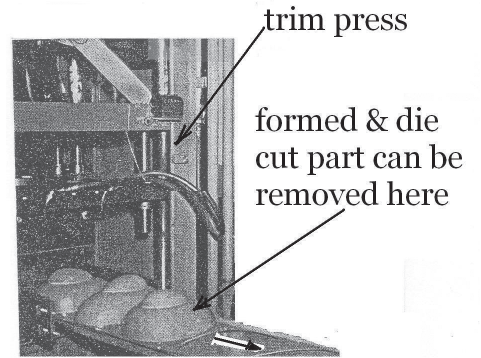

Inline trim station

Fig. 3-4. Plaxall Corp. inline proprietary thermoformer, 1953.

ing that commercial inline roll fed pressure formers utilizing steel rule die cutting were not available until the Brown Bantam 16 (mold size 16 W. x 8 L. inches, 406 x 203 mm) was marketed in 1965 at a reasonable price of \$10,000 (Fig. 3-5). Plaxall maintained a lead far ahead

BORKLAND

The Leading Name in Suction Forming of sheet plastic*

Holder of the United States and Foreign Patents
on Suction* Forming of sheet thermo plastics

World's oldest manufacturers of suction* forming equipment . . . drape, cavity, plug, embossing, skin-pack.

Builders of machines to meet your individual needs.

Originators of suction forming and consultants to leading firms.

For speed, quality, versatility and uniformity, insist on a Borkland.

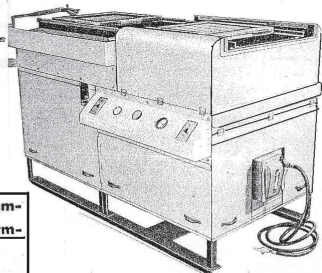

***Suction Forming . . . commonly called "vacuum forming" erroneously.**

Fig. 3-3. Borkland Lab's "suction forming machine," 1955.

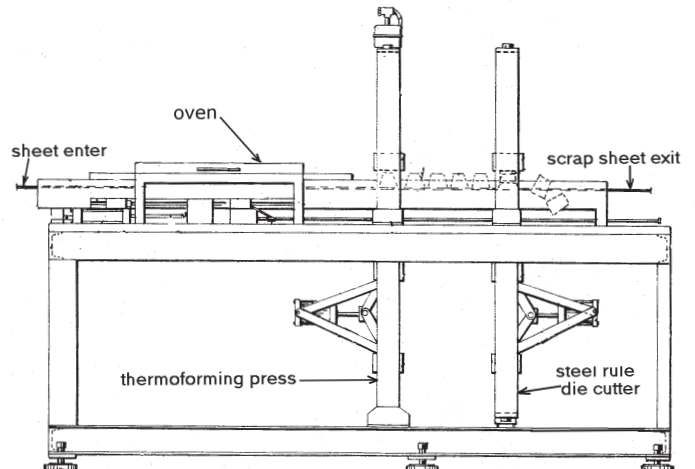

Fig. 3-5. Brown inline thermoformer and steel rule die cutter, 1965.

of their competition because they had been willing to invest in equipment that was quite visionary. This firm was acclaimed by the packaging industry for its creativity and production of high quality formed parts it continued on as a family owned entity into the present time.

Kraft Foods, Chicago, Illinois, in the late 1940s, needed a single service portion blister package for jellies, jams, etc. for its restaurant customers. Before these individual sealed packs were available, most restaurants provided unsanitary common-use containers for the dining public. Portion package designs and equipment described in an article in *Modern Plastics*, May 1952 was acquired by Kraft from the firm, Foodies of Manhattan Ltd. The production rate of 300 units/minute probably was achieved using a rotary drum thermoformer. An earlier Kraft patent (Fig. 3-6) described the pressure

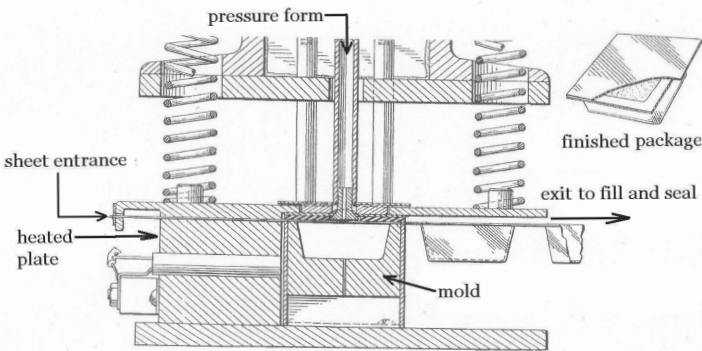

Fig. 3-6. Kraft Foods portion blister packaging, fill and seal machine designed by Theodore Lowe. Filed 1952.

forming of this container as a component of an inline fill and seal machine operating at a much lower production rate.

The specialized thermoforming equipment described here were not low cost universal machines which could be adapted for small part quantities or for large area components.

Bow Stratton of the Army Map Service published a detailed and comprehensive article in *Modern Plastics* magazine, September 1950, of the many years of experimentation to vacuum form contour maps (Fig. 3-7). His description and photos of the mold, radiant heater, vacuum system and clamp frame was sufficient for any competent machine designer to develop commercial versions from this information.

Industrial Radiant Heat Corp., Gladstone, New Jersey, in 1950 negotiated the first sale of a commercial vacuum forming machine (Fig. 3-8). This equipment contained many elements of the Army Map Service vacuum forming designs, including:

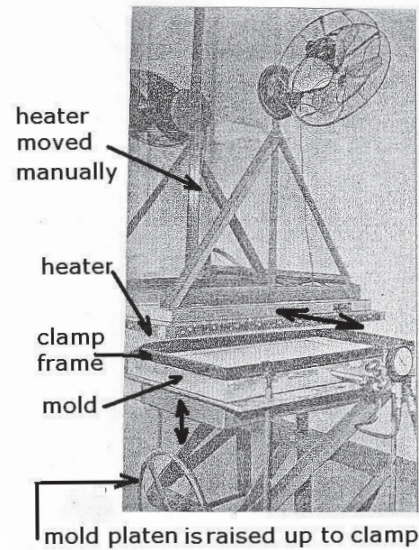

Fig. 3-7. Army Map Service vacuum former served as a prototype for commercial equipment, late 1940s.

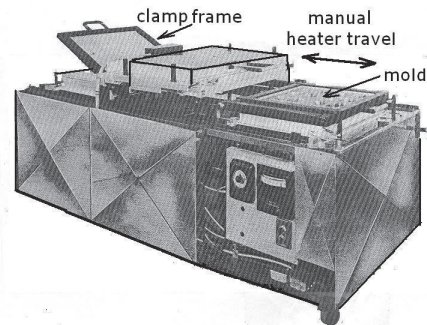

Fig. 3-8. Industrial Radiant Heat Corp. double mold vacuum former, 1953.

Traveling Super Heater consisting of bare nichrome wire sewn into a fiberglass cloth which provided an even heat up to 700°F (371°C). This oven was manually moved to and from the clamped sheet and mold by the operator.

Hinged Top Clamp Frame firmly held the plastic sheet directly against a raised wall built around the periphery of a female mold during the heating cycle.

Duct Tape an Essential. Used to seal the mold to prevent vacuum leaks and to the author's mind, was the main tool employed by many of the early thermoforming operators for multiple purposes. It was applied to cuts and bruises, repairing leaking air and water hoses and also substituted for nuts and bolts and served as a fastener to repair equipment.

Blow off Valve. Supplied compressed air to eject the formed parts from the mold cavities and negated the incorporation of a mechanical stripper within the tool for difficult to release shots.

Industrial Radiant Heat Corp. was the first firm to advertise and demonstrate its vacuum forming machine at a trade show in 1952. Some of its early customers were

(continued on next page)

(continued from previous page)

quite varied and comprised a broad range of industry – Auburn Button Works, National Organ Supply, Kelvinator Corp., Dow Chemical, Pratt Institute, Gladwin Plastics, Einson-Freeman, etc. The firm appears to have left the industry by 1955 as no mention was noted in periodicals after that period.

Autovac Corp., Bridgeport, Connecticut, incorporated in February 1953 by Bow Stratton and partner Bob Butzko, marketed a line of vacuum formers with solid engineered features. Their oven contained tubular heating elements, a metallic heat reflector with thermal insulation which was regulated by a temperature controller, a timer and used pneumatic cylinders to drive the oven. Very soon the complete cycle was automated which contributed to consistent forming and high quality finished products (Fig. 3-9).

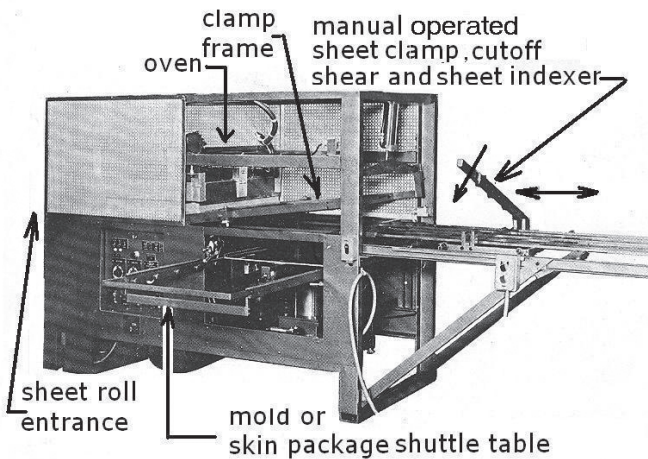

Fig. 3-9. Autovac Corp. The first commercial roll-fed continuous vacuum forming or skin packager, 1954.

In 1953, an important advance in sheet clamp frame design was embodied in a two-piece assembly with an upper member hinged to the lower section and the whole unit was then moved vertically up or down. Previously, the clamp frame was stationary with a hinged section that clamped the sheet directly to the female mold. Hence only female or shallow male cavities could be formed using this early type of clamp frame. Nor is it clear how compensation for hot sheet sag was achieved. The new vertical moving clamp frame was advertised to be used either for **drape** (male cavities) or **vacuum forming** (female cavities) and also to assist ejection of a formed part from the mold (Fig. 3-10). Modern thermoformers are now rarely designed with a stationary mold and a vertically traversing clamp frame instead the mold is secured to a moving platen and the sheet line is fixed.

The drape feature appeared simultaneously in 1953 on both Autovac Corp. and **Vacform Corp.**, Port Wash-

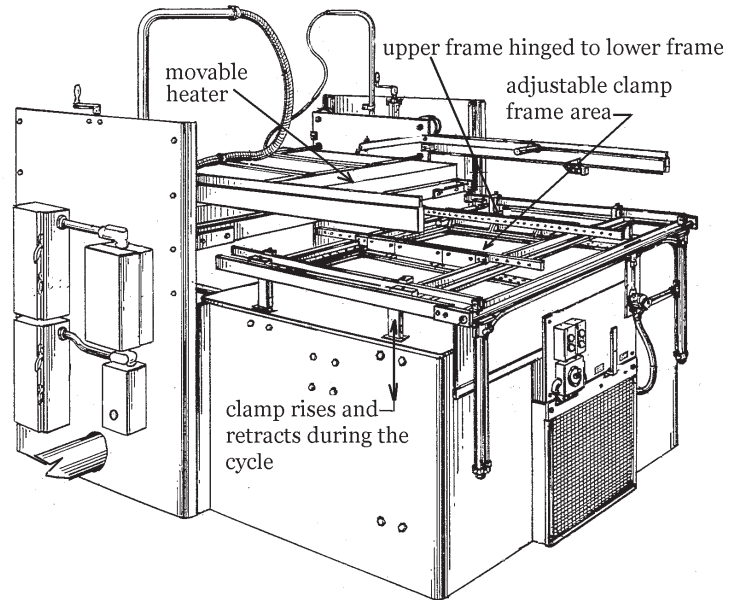

Fig. 3-10. Autovac Corp. cut sheet vacuum former with a fully adjustable clamp frame for the various mold areas. The frame can accommodate male or female cavities, 1954.

ington, N.Y. vacuum forming machines. **Sanford S. Zimmerman**, founder of Vacform Corp., built his machinery in a very robust manner and the designs were very well engineered. This company was eventually sold to **Emhart Corp.** (glass machinery builder) of Hartford, Conn. (Fig. 3-11).

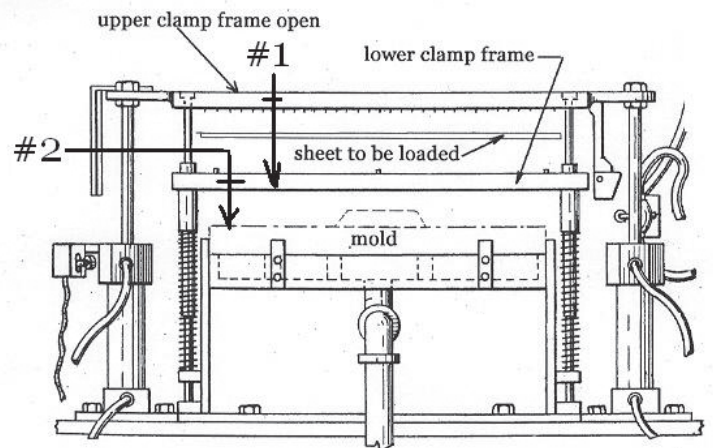

Fig. 3-11. Vacform Corp. Drape vacuum forming clamp frame, 1953.

Skin packaging, a close relative to thermoforming, substitutes a consumer product for a male cavity. The part is encased with hot plastic sheet which is tightly drawn by vacuum and sealed to an underlying porous printed card coated with heat activated cement. This process requires loose products not to shift from their registered spots on the card that had been previously placed on the machine's stationary base. The clamp frame then actuates vertically bringing the heated sheet to the parts for packaging. During this early development period,

vacuum forming equipment advertising promoted its dual ability as a skin packager. Later the two processes separated and each type of machine was specifically designed and sold only for a single purpose.

David Zelnick, President of **Atlas Vac Corp.**, Rochester, N.Y. in 1954, designed and constructed a complete line of vacuum forming machines. Mr. Zelnick in his prior position as a plastic sheet salesman for **U.S. Rubber Corp.** constructed his first vacuum former using an old refrigerator compressor (for vacuum) which his firm demonstrated at the National Plastics Show in 1952. Since this early entry into thermoforming, Mr. Zelnick and his family members continue to operate **Zed Industries** of Vandalia, Ohio whose machines range from sample prototype to high volume thermoformers and many auxiliary machines.

Chicago, Illinois was a heavily industrialized area which quickly encouraged the growth of thermoforming machinery manufacturing. **Comet Industries**, Franklin Park, Illinois in 1955, advertised double forming stations serviced by a single pivoted oven rotating overhead between stations. The founding Kostur family of father and sons built many types of thermoformers but were best known for their advocacy of electric motor driven platens rather than air cylinders for cut sheet formers (Fig. 3-12). This type of platen drive was further per-

vacuum formers which were heavily promoted in 1954 (Fig. 3-13). Eventually the equipment was modified to suit the special needs of the skin packaging industry. ■

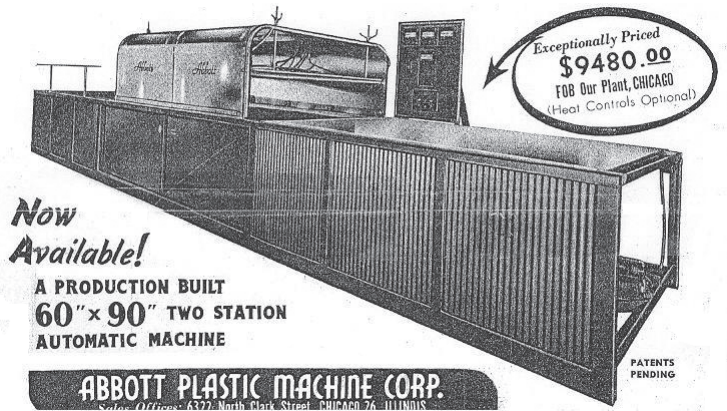

Fig. 3-13. Abbott Machine Corp. large area vacuum former, 1954.

References

- Note: Patented Machines were often sold before the patents were filed.*
- Article - *First National Plastics Exposition - Modern Plastics*, July, 1946, Editorial.
- Ad - *Radiant Heat Inc. - Plastics World*, June 1954.
- Article - *Packaging Institute Forum - Vacuum Formed Thermoplastics - New, Needed, but not by Novices - Modern Packaging*, December 1954.
- Ad - *Borkland Laboratories, Inc. - Modern Plastics*, April 1955.
- Article - *Plaxall Corp. - Automatic Sheet Forming - Modern Plastics*, July 1953.
- Brown Machine Co. - Inline thermoformer and Steel Rule Die Cutting - Brown Patent No. 3,513,505 filed October 5, 1966.*
- Article - *Kraft Foods - One Portion at a Time - Modern Plastics*, May 1952.
- Kraft Foods - Single portion package - Patent No. 2,736,150 filed February 28, 1952 and Patent No. 2,649,392 filed March 30, 1950.*
- Article - *Bow Stratton, Printed Sheets Precision Formed - Modern Plastics*, September 1950.
- Ad - *Industrial Radiant Heat Corp. Vacuum Former - Modern Packaging*, April 1953.
- Fifth National Plastics Exposition - Industrial Radiant Heat Corp. demonstrated the first commercial vacuum former - March 1952 in Philadelphia, PA.*
- Article - *Autovac Corp. - Notice of founding of firm - Modern Plastics*, February, 1953
- Thermtrol Corp. - Contact Heat Pressure Former - Patent No. 3,113,345 filed August 24, 1961.*
- Shuman - Large Manual Vacuum Former - Patent No. 3,553,784 filed December 14, 1967.*

(continued on next page)

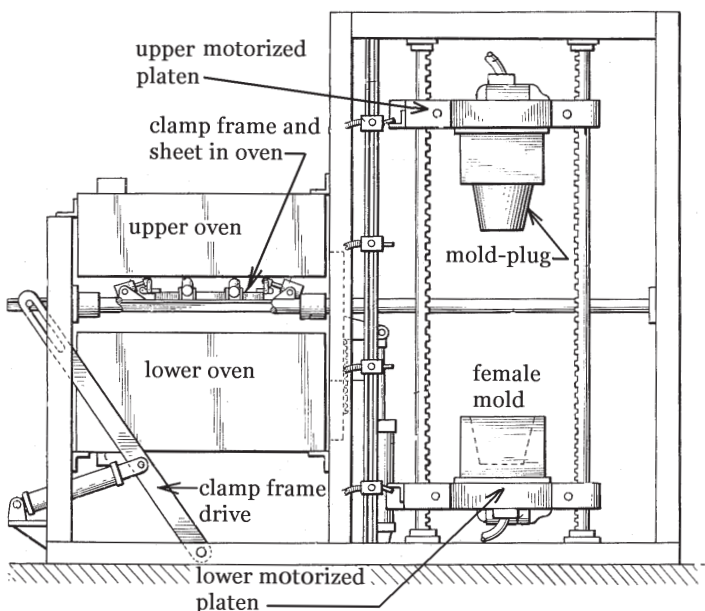

Fig. 3-12. Comet cut sheet vacuum former with electric motor driven dual platens, 1959.

fectured and became a specialty of the **MAAC Machinery Corp.**, Carol Stream, Ill. established by **Paul V. Alongi** in 1982. **ABBOTT Plastic Machine Corp.**, Chicago, Illinois, built very inexpensive large area

(continued from previous page)

Packaging Industries - Form, Fill and Seal - Patent No. 2,970,414 filed December 18, 1958.

Autovac Corp. - Roll Fed Vacuum Former - company literature.

Ad - Autovac Corp. - Drape Vacuum Former - Plastics World - December 1953.

Autovac Corp. - Cut Sheet Vacuum Former - Patent No. 2,836,852 filed March 8, 1954.

Vacform Corp. - Drape Vacuum Forming - Patent No. 2,989,780 filed July 2, 1953.

Atlas Vac Corp. - History of company - letter from Dave Zelnick, CEO (2005).

Ad - Comet Industries - Dual Station Vacuum Former - Modern Plastics, February 1955.

Comet Industries - Motorized Platen Vacuum Former, Patent No. 3,025,566 filed February 9, 1959.

Ad - Abbott Plastics Machine Co. - Large Manual Vacuum Former - Plastics World, August 1954.

Plax Corp. - Contact Heat Pressure Former - Patent No. 3,004,288 filed October 19, 1955.

Tronomic Corp - Roll Fed Vacuum Former - Patent No. 3,153,813.

Brown Machine Co. - History of Company - Internet.

Brown Machine Co. - 42 P. Thermoformer Press - Patent No. 3,346,923 filed July 10, 1963.

Brown Machine Co. - Web Indexing Chain - Patent No. 3,216,491 filed October 28, 1963.

Article - Hydro-Chemie - Vacuum Molding - Modern Plastics, November 1953.

Article - British Sheet Forming Progress - Modern Plastics, April 1953.

Article - Edwards & Co. Ltd. - Vacuum Forming Machine - Plastics World, July 1954.

Article - Morane Plastics Co. Ltd. - Skin Packaging Machine - Modern Plastics, September 1955.

Adolf Illig Maschenbau - Company History - Internet - UA-100 Vacuum Former - photo from company literature.

These sponsors enable us to publish **THERMOFORMING QUARTERLY**

NH NEW HAMPSHIRE PLASTICS

High Impact Polystyrene

Phone: (800) 258-3036

Fax: (603) 622-4888



Sales of new and used plastic equipment

Your First and Only Stop for Buying and Selling in the Plastics Industry

VISIT US ONLINE AT WWW.STOPOL.COM

EQUIPMENT SALES - AUCTIONS - LIQUIDATIONS - APPRAISALS - BUSINESS SERVICES - PARTS

Stopol is *the* plastics industry leader in providing solutions for processors' production needs through its six lines of business — Equipment Sales, Auctions, Liquidations, Appraisals, Parts and Business Services (merger and acquisition consulting). Drawing on its vast inventory, infinite web of industry contacts, unmatched market intelligence and keen industry knowledge, Stopol offers an endless array of equipment options for both buyers and sellers:

THERMOFORMING - INJECTION - EXTRUSION - BLOWMOLDING - ROTATIONAL MOLDING

And with the emergence of Stopol's new online auction portal and marketplace — buying and selling in the plastics industry has never been more easy, efficient and cost effective, particularly for those in the thermoforming arena. Stopol boasts a rich legacy of success and decades of experience with thermoforming equipment, companies and trade organizations. Stopol's seasoned professionals serve as strategic partners for our client base, helping companies find cost-effective solutions while maximizing their resources. The results? Innumerable benefits and advantages for both buyers and sellers:

BUYERS' BENEFITS

- Maximize your purchasing dollars
- Find deals and locate specific equipment
- Increase your output, upgrade production capabilities
- Eliminate the wait for equipment to become available from OEMs
- Reduce amount of time and money spent looking for machinery
- Limit start-up costs for entrepreneurs

SELLERS' ADVANTAGES

- Maximize the value of your company and its assets
- Convert surplus machinery into cash quickly
- Market your equipment to a global audience
- Reduce your inventory
- Exchange older machines for newer models

STOPOL, Inc., 31875 Solon Road, Solon, OH 44139 U.S.A.
Ph: (440) 498-4000 • Fax: (440) 498-4001 • www.stopol.com

Appraisals • Plant Liquidations • Auctions • Trade • Lease

Process – Cycle Time

BY BARRY SHEPHERD

(Editor's Note: This is the first Thermoforming 101 article written by your new technical editor. Dr. Throne wrote 34 articles that date back to 1998, Volume 17, Number 3. He had originally intended to write a series of 18 general interest articles but the 101 series has become a mainstay of the Quarterly. The year-end booklet that contains every 101 article to date is a great reference source for thermoforming practitioners. This technical editor has every intention of maintaining the series and the booklet which is becoming the perfect reading material for people entering the industry or seasoned personnel who need help on a specific problem. Jim wrote 4 articles last year that dealt with part design. I hope he will forgive me for not continuing with the "Trimmed Edge" topic he suggested for this lesson. I will deal with this topic when we take a closer look at the subject of "Die-Cutting." This Thermoforming 101 article deals with a subject about which we should all be more diligent. Foreign competition has forced us to maximize efficiency and become more competitive. So let us review the basic factors that determine cycle time.)

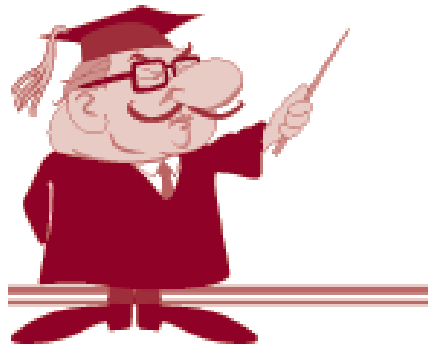

THERMOFORMING 101

General Assumptions

We all should be aware that if we let the operator determine when a machine cycles, our production rate will suffer. Running thermoforming machines on manual mode is necessary for set up and of course if all you have is a simple shuttle machine with rudimentary controls you have no other choice. So let's just deal with thermoforming in automatic mode. We will only deal with the forming part of the process. Trimming of heavy gauge parts is another topic. Also for this purpose we will assume that when thinking roll-fed, we are using a machine with in-line die-cutting.

The Basic Concept

If we take all the segments of the rotary or in-line thermoforming process: heating, indexing the sheet, closing the press, forming the part, cooling the part, opening the press,

trimming and stacking (if in-line), the cycle time is dictated solely by the slowest segment of the process. Most people looking at our process for the first time will say it has to be the heating segment that is the slowest part of the process. This is not necessarily so.

Roll-Fed

It is especially not so with roll-fed machines that usually are designed to have 4 indexes in the ovens. For example if the maximum mold size in the index direction is 36". The oven length will be roughly 4 times 36" or 12 feet long. So if you are running .020 PVC which would normally be in the oven for 20 seconds to get up to forming temperature, your cycle time, based on a 4 index oven, is 5 seconds (20 divided by 4) or 12 cycles per minute. This is not bad for running smaller and medium size quantities but it can be a lot better. I will explain later.

(continued on next page)

Sheet-Fed

OK, so what about heavy-gauge, sheet-fed forming? The same principle applies. In North America the machinery manufacturers recognized early on that they must do something about the length of time it takes to heat the sheet evenly and thoroughly. So the 4 station rotary machine was designed which cut heating time dramatically by using 2 heater banks through which the sheet travels on its way to the mold. So why not build a 5 station rotary with 3 heater banks and really cut heating time? The answer is, there would be no point unless the part could be formed and cooled in a time less than one third the heating time. In fact the cooling of some materials is so difficult that one heater bank on a 4 station would have to be shut off or set at a lower temperature to allow time for proper cooling. So if we can do things to speed up the heating of the sheet, what can we do to cool the part quicker? This is where it gets tricky.

The Forming Segment of the Cycle

On roll-fed machines, unless you are dealing with super fast lines, you can forget about the trimming and stacking segments of the cycle when looking for what is slowing you down. Concentrate on the forming segment from the time the sheet leaves the heaters to the time the formed part leaves the form

station. Let's break down the actions that take place.

Index speed is the speed that the sheet travels from the heaters to the form station. Roll-fed pin chains can travel up to 95 inches per second. A rotary turntable moves a lot slower. On both roll-fed and sheet-fed lines the stopping and starting actions can become too violent if the index speed is too fast which may cause the hot sheet to move as the mold closes on it. Move the sheet as fast as possible but make sure that the drape is stationary when the mold closes.

Shut height or platen travel is the distance the form platens must travel from the open position to the closed position. All too often set-up people will not take the time to reduce the shut height to optimum levels. I have seen a roll-fed job running very shallow pill blisters with a female tool on the bottom and the plugs on the top showing 3 inches of daylight between the plugs and the sheet line because the operator did not lower the shut height of the top press. This added at least 1 second to the cycle time and over a 30 hour run at 15 cycles per minute added over 2 hours of unnecessary labor and machine time. If you don't have shut height adjustment on your form press the only way to do this is to add build ups behind the tooling. Fortunately the new machines have electric presses which make setting the shut height so much easier.

Press speed affects the length of the cycle time but sometimes it is necessary to slow the press closing speed to accommodate

plug or assist action. If you are having difficulty with de-molding you may need to slow the opening speed. Other than these conditions, you can move the platens as fast as you want. Third motion tooling or independent plug control with individual cavity clamping can greatly improve cycle time but this is getting beyond the scope of a 101 article.

Cooling time is by far the most important factor in achieving a fast cycle time. In my very early days of thermoforming we tried running an epoxy mold on a modern in line machine. Even with a water cooled base under the mold the best we could do is 2 cycles per minute simply because the mold never got a chance to cool down. Using an aluminum mold on a water cooled base allows you to run most jobs at reasonable speeds as long as the height (or depth if it's a female) of the mold is no more than say 2 inches. To achieve maximum efficiency and reduce cooling time the mold must be kept at the target temperature as specified by the material supplier. Hot material at 350 degrees F hitting the metal mold requires a very efficient cooling system to maintain that mold temperature that may have to run at 200 degrees F constantly to run fast cycles. The only way to do this is to run cooling lines in the mold itself usually no more than 2" to 3" apart depending on the size and configuration of the mold. Cast-in lines are the norm for aluminum cast molds and machined in lines are the norm for machined aluminum molds.

Cooling time on sheet-fed rotary machines running thick HDPE can be improved by using external fans, water mist or cold air directed onto the part but care must be taken not to form in stresses. A well built water cooled mold is still necessary for the most significant improvement in cycle time.

So how do some roll-fed thermoformers get 50,000 parts per hour? This will be the subject of technical articles in the future. It's not a subject for the 101 series but here is a hint: third motion tools, cavity clamping, pre-heaters and great cooling in the molds.

Cycle time is just one way to make our operations lean and more competitive. Other ways will be discussed in future Thermoforming 101 articles. ■

These sponsors enable us to publish **THERMOFORMING QUARTERLY**

**If you want to lead
you have to get in-line.**

By far, the most efficient way to produce thermoformed packaging is with a Welex In-Line Extrusion System.

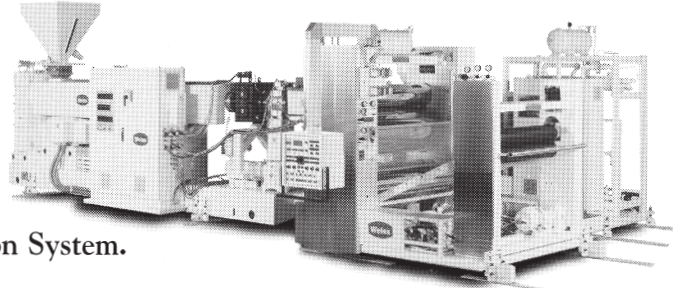

Welex Incorporated
850 Jolly Road, Blue Bell, PA 19422
Tel(215) 542-8000 FAX(215) 542-9841
E-mail: welex@welex.com



For superior flatness, machinability and dimensional stability in aluminum plate...

“Good enough” is never good enough.

When parts must work every time, don't compromise quality.

MIC6® Precision Machined Cast Aluminum Plate is the ultimate standard for critical applications:

- Checking fixtures
- Food processing, packaging and printing equipment
- Semi-conductor holding trays
- Base plates, side panels and indexing tables

Only MIC6® is cast to near net thickness with a stress-relieved, granular structure to virtually eliminate distortion from machining and temperature fluctuations. Plus it delivers superior flatness and surface finish.

Plates claiming to be “good enough” just aren't. The dependable choice is MIC6® Precision Machined Cast Aluminum Plate. Learn more at:

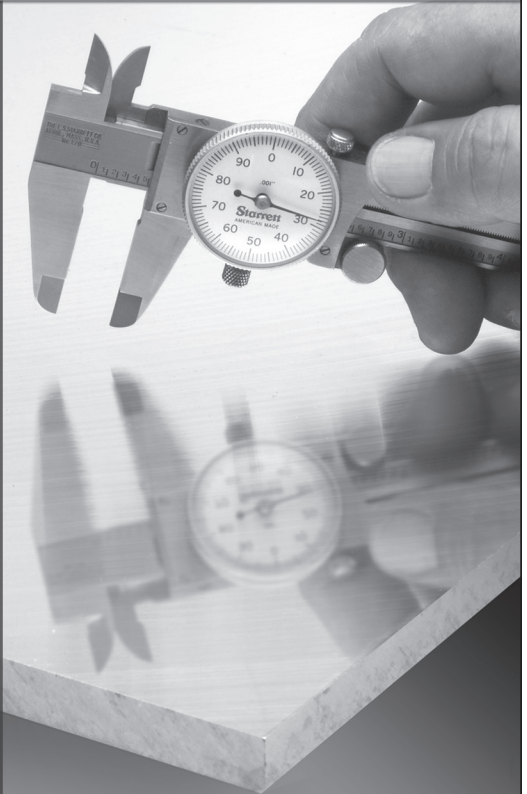

**2008 EUROPEAN
THERMOFORMING
CONFERENCE
ANNOUNCED**

April 3 – 5, 2008

**Berlin, Germany
Maritim Hotel Berlin**

**For further information,
contact Kitty Beijer at**

Beijer_k@senoplast.com

ThermoformingSI@aol.com

Spe.Europe@skynet.com



Alcoa Global Mill Products
800-854-4762
www.alcoamic6.com



**Precision Machined
Cast Aluminum Plate**



Thermoforming Division

Help Sponsor

Thermoforming[®] Quarterly

ONE YR. SPONSORSHIPS

**Please note the increase in sponsorship rates. This is the first increase since the inception of the Thermoforming Quarterly in 1981. We appreciate your continued support of our award winning publication.

Patron - \$625

(Includes 2.25" x 1.25" notice)

Benefactor - \$2,000

(Includes 4.75" x 3" notice)

Questions?

Please Contact:

Laura Pichon

Ex-Tech Plastics

847/829-8124

lpichon@extechplastics.com

We Appreciate Your Support!

From The Editor

Thermoforming Quarterly welcomes letters from its readers. All letters are subject to editing for clarity and space and must be signed. Send to: Mail Bag, Thermoforming Quarterly, P. O. Box 471, Lindale, Georgia 30147-1027, fax 706/295-4276 or e-mail to: gmathis224@aol.com.

These sponsors enable us to publish **Thermoforming Quarterly**



GN
Thermoforming Equipment

GN DM series thermoformers

*... be part
of the GN family*

The GN DM with patented technology is a plug-assist machine
Robotic product handling system | Built-in diagnostic system
Multi-zone upper and lower ovens | Positive and negative forming
Quick tool changes



www.gnplastics.com | Chester | Nova Scotia | Canada | Tel +1-902/275 3571

the **ONSRUD** advantage

**Your Number 1 Source
for Cutting Tools to the
Thermoforming Industry**

the
ONSRUD
advantage
more than just cutting tools

ONSRUD CUTTER LP
800 Liberty Drive • Libertyville, IL60048, USA
Phone 800.234.1560 • Fax 847.362.5028
www.onsrud.com • www.plasticrouting.com

LMT Leitz Metalworking Technology Group

**Cutting Tools for ALL
Trimming Applications**

- Multi-Axis
Robotic
Routers
- 3 and 5
Axis CNC
Routers
- Hand-Held
Routers

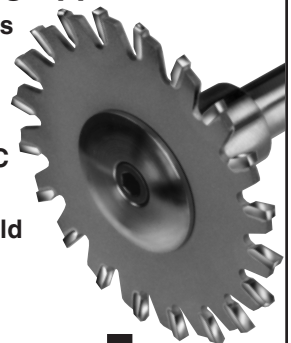

thermoforming

These sponsors enable us to publish

THERMOFORMING QUARTERLY



65 South Waukegan Road
Lake Bluff, IL 60044

Custom Engineered Plastic Parts
Vacuum • Pressure • Twin Sheet
We Deliver Parts Under Pressure!

ISO 9001:2000

(847) 604-5100

FAX (847) 604-8030



www.pcmwi.com

Quality Thermoform Molds
Since 1972

Portage Casting & Mold, Inc.
2901 Portage Road, Portage, WI 53901
1-800-356-5337 — Fax 1-608-742-2199



Productive Plastics, Inc.
Award Winning Thermoforming



103 West Park Drive • Mt. Laurel, NJ 08054
(856) 778-4300 • Fax: (856) 234-3310
<http://www.productiveplastics.com>

**Flameless
Catalytic
Infrared
Gas Heaters**

- New, Used and Factory Refurbished Heaters
- On-site Refurbishing Services



AMERICAN CATALYTIC TECHNOLOGIES

Since 1992 Branford, CT 06405 • Phone 800-648-1698
Fax 203-483-6693 • www.americancatalytic.com

These sponsors enable us to publish **THERMOFORMING QUARTERLY**



Thermoforming & Extrusion Consultants • Manufacturing Processes Analysis
In-house Training and Seminars • Turn-key Project Management
Market Development • Advanced Materials Forming • Product and Design Development

Coming Soon – 2007 Seminar Schedule



PLASTIC CONCEPTS AND INNOVATIONS^{LLC}
Guiding Innovations in the Development & Production of Thermoformed Products

Contact: Jay Waddell jwaddell@plasticconcepts.com • Ph: 843-971-7833 • Fax: 843-216-6151
1127 Queensborough Blvd. • Suite 102 • Mt. Pleasant SC 29464 USA • www.plasticconcepts.com

Want to improve your thermoforming process?

Raytek delivers results you can see with the TF100 thermal process imager:

- Reduce set-up time by 50%
- Increase throughput and profitability
- Automatically detect failed heating elements
- View and save thermal images for every part
- Eliminate guesswork from heater adjustments
- Quickly verify new tools and new molds

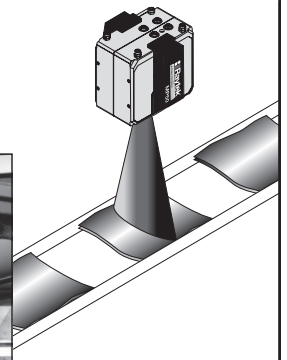
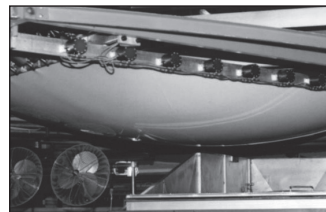

Raytek[®]
A Fluke Company

www.raytek.com/tfresults • 1-800-227-8074

Worldwide Leader in Noncontact Temperature Measurement for the Thermoforming Industry

MARK YOUR CALENDAR!

2007 THERMOFORMING CONFERENCE

September 16th - 19th, 2007

Duke Energy Center & Millennium Hotel
Cincinnati, Ohio



2007 PARTS COMPETITION ANNOUNCEMENT

BY HAYDN FORWARD, PARTS COMPETITION CHAIRMAN



W elcome to our introduction of the 2007 Parts Competition.

These are exciting times for our industry and the 2007 Parts Competition will again showcase advancements in thermoforming design, innovation and capabilities.

I'm confident all of you have experienced and introduced many changes in your business over the last year and change is in the air for this year's competition format. I'm pleased to say the changes are in response to numerous ideas and recommendations to enhance the viability of the competition.

Media has shown a strong interest in thermoforming and has requested improvements to assist them in publicizing well deserved recognition of the parts and award recipients.

We will be opening the part entrance door wider by inviting a broader range of those involved in part development, which will generate a new category and winner. In respect to our history of close competition, other award categories will be rolled into a larger grouping and multiple winners announced from that grouping. Contrary to the past, part entries that might have been "a close second place" will now have a greater opportunity of industry recognition.

A simple stream-lined entrance process will be introduced for rapid international announcement of the winners.

The conference committee is gearing up to help educate the industry this year and our parts competition will be part of that effort.

Each submitter's representative will have the opportunity to speak with the press, your peer's, designers, tool makers and OEM's, at a dedicated time and gathering for the occasion.

History has shown that every part entered deserves recognition, but unfortunately every part does not receive an award. In light of this, each entered submittal will receive a "Certificate of Acknowledgment" from the SPE.

Details on these exciting changes will soon be found on our website www.thermoformingdivision.com and in the next *Quarterly*.

It'll be easy to start thinking now about how to take advantage of this once a year opportunity to showcase your capabilities, research and introduce your firm to and through the press.

I'm encouraging you to take a few moments and forward your e-mail address to me at hforward@smi-mfg.com. Once sent, you'll be on the list to receive the necessary, short and easy, instructions to enter the 2007 SPE Thermoforming Division Parts Competition. ■

Register Today and Save \$100

Industrial Thermoforming Symposium & Workshop
For Thin & Heavy Gage Thermoforming
March 5-9, 2007
Crowne Plaza
Dallas, Texas

Symposium Leader: William "Bill" K. McConnell, Jr.
Guest speakers will share their expertise

Don't Miss This Yearly Event!

- Review the basic concepts of thermoforming and expand your understanding of thermosets and thermoplastics
- Plant tours, group lunches, sponsored receptions and dinner will encourage maximum exposure and interaction between attendees and professional leaders in the thermoforming industry

Tours include guided visits of:
Spartech Plastics - a custom sheet extrusion plant
Kinro Composites - a large, cut-sheet, custom thermoforming plant
Skyline Career Development Center - a career development high school's plastics shop

Presented by the Society of Plastics Engineers
with the Thermoforming Division

Sponsor Opportunities Available

 For detailed information & registration visit www.4spe.org/training/seminars

2007 THERMOFORMING EXHIBITS FOR CINCINNATI

*Get an early start – reserve your space now ...
call Gwen Mathis at 706/235-9298.*

ALCOA KAMA CORPORATION

ALLEN EXTRUDERS, INC.

AMERICAN TOOL & ENGINEERING, INC.

AMETEK LAND, INC.

ARISTECH ACRYLICS LLC

BASELL

BROWN MACHINE LLC

EX-TECH PLASTICS, INC.

GEISS THERMOFORMING USA, LLC

INVISTA S.A.R.L.

KLEERDEX COMPANY LLC

KLOCKNER PENTAPLAST

MAAC MACHINERY

MODERN MACHINERY OF BEAVERTON, INC.

NEW HAMPSHIRE PLASTICS

ONSRUD CUTTER LP

PORTAGE CASTING & MOLD, INC.

PREMIER MATERIAL CONCEPTS

PRIMEX PLASTICS CORPORATION

PROCESSING TECHNOLOGIES

RAYTEK CORPORATION

ROYCE ROUTERS

RTP COMPANY

SENCORP, INC.

SENOPLAST USA

SPARTECH CORPORATION

STOPOL, INC.

THERMWOOD CORPORATION

TOOLING TECHNOLOGY LLC

TOPAS ADVANCED POLYMERS, INC.

ZED INDUSTRIES

**THERMOFORMERS, HAVE
YOU DISCOVERED A
FORMING TIP THAT YOU
ARE WILLING TO SHARE
WITH YOUR FELLOW
FORMERS?
A TIME SAVER?
OR A COST SAVER?
OR SOMETHING THAT
WILL SAVE WEAR AND
TEAR ON YOUR MACHINE?
OR YOUR EMPLOYEES?
THEN THE**

Forming TIPS

**COLUMN
IS FOR YOU!**

Just send Barry Shepherd a fax at 905-459-6746, outlining your tip in less than a couple hundred words. You can include drawings, sketches, whatever. Thanks!

These sponsors enable us to publish **THERMOFORMING QUARTERLY**

Equipment Appraisals
We want to buy your surplus!

plastIMACH
CORP

**sheet fed inline rotary
3 & 5 axis routers**

The Source for Used Thermoforming & Trimming Equipment
Serving the SPE since 1975

www.plastimach.com 800-394-1128 tel

MODERN Custom. Reliable. Flexible.

Celebrating 25 years of leadership in the Thermoforming Industry, providing the latest technology and customized solutions for your thermoforming and auxiliary process needs.

MODERN provides:

- **Customized** Process Solutions.
- **Reliable** and On-time Machinery.
- **Flexible** Quick-Change Equipment Features.
- The most responsive After-the-Sales support.
- MODERN-ize Kits to Update and Upgrade your existing equipment, Modern or otherwise.
- Full service parts department for Modern and competitive brands.

MODERN
MACHINERY
OF BEAVERTON, INC.

PO Box 423 Beaverton, MI 48612 • 989-435-9071 • FX: 989-435-3940 • www.modernmachineinc.com

More Than Machines.

We're more than just thermoforming machines. Brown is a process engineering team and a machine & tooling group that is focused on discovering the best process and machine combination to optimize your production output.

Contact us today at www.brown-machine.com

BROWN® Machine

These sponsors enable us to publish

THERMOFORMING QUARTERLY

www.americanthermoforming.com



Rotate Kits
Oven Kits
New Controls
Complete Rebuilds
Machine Installations
Service Work

(989) 345-5394
(989) 751-2262

These sponsors enable us to publish **THERMOFORMING QUARTERLY**



KMD Series Machine
High Performance Pressure Forming
for Packaging Parts for a variety of Industries



*The experience to
form your future.*

KIEFEL TECHNOLOGIES, INC.
7 Scott Road
Hampton, NH 03842
Tel: 603-929-3900 • Fax: 603-926-1387
www.kiefeltech.com
e-mail kiefel@kiefeltech.com

*We
need
your
continued
support
and
your
efforts
on
membership
recruitment!!*

Tired of dealing with the big guys?

PMC has just what you're looking for.
We are a custom extruder of sheet and roll stock,
specializing in *speed and service*.

- Impact Modified Acrylic
- PremierKote® (UV stabilizing cap)
- ABS
- TPO
- TPE
- PP
- HIPS
- PE
- Specialty Compounds
- Color Matching

Contact PMC with your custom plastic and extrusion needs today!



1-877.BUY.PMC6 (289.7626) | www.buypmc.com | sales@buypmc.com

THERMOFORMING DIVISION DVD'S STILL AVAILABLE

The first DVD is titled:
**"WHAT EXACTLY IS
THERMOFORMING?"**

This six-minute DVD introduces the viewer to the thermoforming process with examples of parts produced and a video of the process. Both thin gauge roll fed and heavy gauge cut sheet fed aspects of thermoforming are illustrated. It is for students, industry and anyone who wished to learn more about thermoforming.

The second DVD is titled:
**"FORMING EDUCATIONAL
OPPORTUNITIES:
GRANTS AND
SCHOLARSHIPS
OFFERED BY THE
SOCIETY OF PLASTICS
ENGINEERS -
THERMOFORMING
DIVISION"**

This six-minute DVD discusses the 13 matching equipment grants of up to \$10,000 and 20 scholarships up to \$5,000 for college students. Information is provided for applying to these grants and scholarships. The Thermoforming Division of SPE has contributed over \$150,000 in equipment grants and scholarships as of this date.

Both DVDs are free of charge and available from SPE through **Gail Bristol** at phone number 203-740-5447 or **Gwen Mathis**, Thermoforming Division, at phone number 706-235-9298.

These sponsors enable us to publish **THERMOFORMING QUARTERLY**

QUICK CHANGE CYLINDER LOCKS

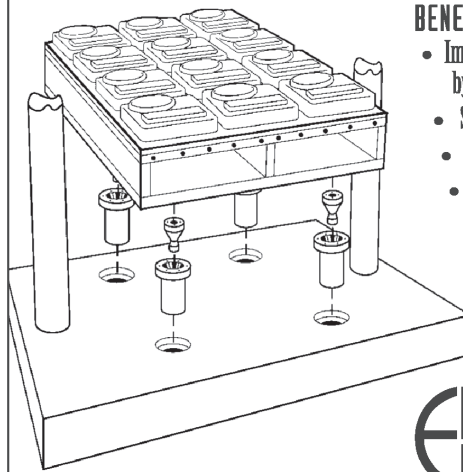

BENEFITS...

- Improve tool change over times... by more than 50%
- Self aligning...precisely repeatable
- No bolts-no wrenches
- Adaptable to all tools and components
- Simple to install



➔ Call for our new catalog

Tel: 937.295.3672 www.segen-online.com



EDWARD D. SEGEN & CO., LLC
A TOOLING TECH GROUP COMPANY
P.O. Box 319, 100 Enterprise Dr., Ft. Loramie, OH 45845



ULTRA-METRIC TOOL CO.

2952 N. Leavitt • Chicago IL 60618 • Ph (773) 281-4200 • Fax (773) 281-6185

THERMOFORM TOOLING



FORM TOOLS

TRIM TOOLS

**OPS PET PP HDPE
EPS**



**PRECISION TOOLS FOR
QUALITY THERMOFORM
PRODUCTS**

***We Design & Build Thermoform
Tooling That Molds Relationships***

30+ Years of Superior Service:

- ◆ Complete Turnkey Service
- ◆ Product Design & Prototypes
- ◆ CAD/CAM Tool Engineering
- ◆ Continuous High Speed Tooling
- ◆ 3rd Motion Machine Driven
- ◆ Form & Trim-In-Line
- ◆ Form & Trim-In-Place
- ◆ Custom Built Mold Bases
- ◆ H₂O Cooled Male/Female Molds
- ◆ Matched Metal Punch & Die Sets
- ◆ Large CNC Milling & CNC Turning
- ◆ Deep Hole Gun Drilling
- ◆ On-time Delivery

← sales@umthermoform.com
www.umthermoform.com



Society of Plastics Engineers

P.O. Box 403, Brookfield, CT 06804-0403 USA
Tel: +1.203.740.5403 Fax: +1.203.775.8490 www.4spe.org

MEMBERSHIP APPLICATION

Applicant Information

Name:
first last mi

Company Name and Business Address (or College):
company/college:
job title:
address:
address:
city: state:
zip: country:

Phone/Fax Format: USA & Canada: (xxx) xxx-xxxx All Others: +xx(xx) x xxx xxxx

Work Phone: **Fax:**

Email: *used for society business only*

Home Address:
address:
city: state:
zip: country:

Home Phone:

Preferred Mailing Address: Home Business

Gender: Male Female

Birth Date: (mm/dd/yyyy)

Demographics

Job Function (choose only one)
 Consulting Purchasing
 Design Quality Control
 Education (Faculty) R & D
 Engineer Retired
 General Management Self-Employed
 Manufacturing Student
 Marketing/Sales Tech Support
 Other

Materials (choose all that apply)
 Composites Polyolefins
 Film Polystyrene
 General Interest TPEs
 Nylon Thermoset
 PET Vinyls
 Foam/Thermoplastics No Interest

Process (choose all that apply)
 Blow Molding Injection Molding
 Compression Mold Making
 Compounding Product Design
 Engineering Properties Rotational Molding
 Extrusion Thermoforming
 Fabrication General Interest
 Foam No Interest

The SPE Online Membership Directory is included with membership. Your information will automatically be included.
 Exclude my email from the Online Member Directory
 Exclude all my information from the Online Member Directory
 Exclude my email from 3rd party mailings

Payment Information

New Member 1 Year <input type="checkbox"/> US (\$122.00) <input type="checkbox"/> Canada (\$162.75) <input type="checkbox"/> Euro (€125.00)	New Member 2 Years * <input type="checkbox"/> US (\$212.00) <input type="checkbox"/> Canada (\$282.00) <input type="checkbox"/> Euro (€219.00)	Student Member <input type="checkbox"/> US (\$28.00) <input type="checkbox"/> Canada (\$37.50) <input type="checkbox"/> Euro (€25.00)	Students must supply graduation date: _____												
My Primary Division is (choose from below) _____			Membership Amount _____												
Additional Divisions are available for a fee. Check below to select Additional Divisions.			Primary Division FREE												
<input type="checkbox"/> Additives & Color Europe (D45) <input type="checkbox"/> Medical Plastics (D36) <input type="checkbox"/> Automotive (D31) <input type="checkbox"/> Mold Making & Mold Design (D35) <input type="checkbox"/> Blow Molding (D30) <input type="checkbox"/> Plastics Environmental (D40) <input type="checkbox"/> Color & Appearance (D21) <input type="checkbox"/> Polymer Analysis (D33) <input type="checkbox"/> Composites (D39) <input type="checkbox"/> Polymer Modifiers & Additives (D38) <input type="checkbox"/> Decorating & Assembly (D34) <input type="checkbox"/> Product Design & Development (D41) <input type="checkbox"/> Electrical & Electronic (D24) <input type="checkbox"/> Rotational Molding (D42) <input type="checkbox"/> Engineering Properties & Structure (D26) <input type="checkbox"/> Thermoforming (D25) <input type="checkbox"/> Extrusion (D22) <input type="checkbox"/> Thermoforming, European (D43) <input type="checkbox"/> Flexible Packaging (D44) <input type="checkbox"/> Thermoplastic Materials & Foams (D29) <input type="checkbox"/> Injection Molding (D23) <input type="checkbox"/> Thermoset (D28) <input type="checkbox"/> Marketing & Management (D37) <input type="checkbox"/> Vinyl Plastics (D27)			Additional Division(s) costs for each Additional Division <table border="0"> <tr> <td></td> <td>1yr.</td> <td>2 yrs.</td> </tr> <tr> <td>US</td> <td>\$6.00</td> <td>\$12.00</td> </tr> <tr> <td>Canada</td> <td>\$8.00</td> <td>\$16.00</td> </tr> <tr> <td>Euros</td> <td>€5.00</td> <td>€10.00</td> </tr> </table>		1yr.	2 yrs.	US	\$6.00	\$12.00	Canada	\$8.00	\$16.00	Euros	€5.00	€10.00
	1yr.	2 yrs.													
US	\$6.00	\$12.00													
Canada	\$8.00	\$16.00													
Euros	€5.00	€10.00													
			TOTAL _____												

CHECK VISA AMEX MASTERCARD

card number _____

expiration date (mm/yyyy) _____

PAYMENT MUST ACCOMPANY APPLICATION
Sorry, No Purchase Orders Accepted

Checks must be drawn on US or Canadian banks in US or Canadian funds.
Dues include a 1-year subscription to *Plastics Engineering* magazine.
SPE membership is valid for twelve months from the month your application is processed.
*save over 10%

By signing below I agree to be governed by the Constitution and Bylaws of the Society and to promote the objectives of the Society. I certify that the statements made in the application are correct and I authorize SPE and its affiliates to use my phone, fax, address and email to contact me.

signature _____ date _____

recommended by member (optional) _____ Id # _____

These sponsors enable us to publish

THERMOFORMING QUARTERLY

ALLEN

CUSTOM THERMOPLASTIC SHEET

1305 Lincoln Avenue, Holland, MI 49423
PH (800) 833-1305 / FX (800) 832-5536
www.allenx.com

ABS	ABSFR	PCABS
HIPS	HIPSFR	GELOY
CENTREX	LURAN	NORYL
	SOLARKOTE	

A Tradition of Excellence Since 1970

50 YEARS PROVIDING

SOLUTIONS IN PLASTICS



McClarin Plastics, Inc.

800-233-3189
717-637-2241 • Fax: 717-637-2091
600 Linden Avenue
Hanover, PA 17331
www.McClarinPlastics.com
E-Mail: mcclarin@mcclarinplastics.com

PRIMEX PLASTICS CORPORATION

A Quality Custom Sheet Extruder!

Polystyrene	Polyethylene	ABS
Polypropylene	Polyester	Cor-x

1-800-222-5116

www.primexpastics.com

Large enough to handle your requirements,
Small enough to handle your needs...

ZED INDUSTRIES, INC.

The Best In

Thermoforming Machinery,
Tooling, and Automation Solutions

3580 Lightner Rd. Vandalia, Ohio
(937)-667-8407, Fax (937)-667-3340
E-Mail: Info@ZedIndustries.com

THE FOX MOR GROUP, INC.

Serving the Plastics Industry with Expertise and Integrity.

Your One-Stop Resource for
Thermoforming Equipment & Sales

• Machines • Accessories • Automation • Consulting

Roger Fox • David A. J. Morgese

(630) 653-2200 • www.foxmor.com

These sponsors enable us to publish **THERMOFORMING QUARTERLY**

Innovative Tooling Materials for Thermoforming



RENSHAPÉ®
Prototype Boards

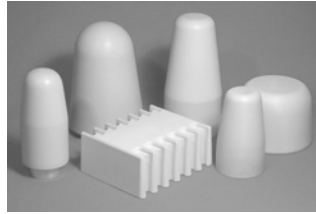

HYTAC®
Plug Assist Materials

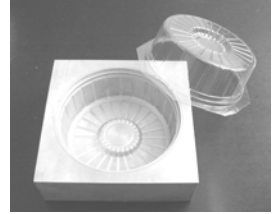

METAPOR®
Porous Aluminum



CMT MATERIALS, INC.

info@cmtmaterials.com

www.cmtmaterials.com

TEL (508) 226-3901

FAX (508) 226-3902

WORLD CLASS SHEET EXTRUSION SYSTEMS

NEW!

REVOLUTION® Sheet Extrusion Machinery



■ Ideal for APET, PP,
PS, PLA, PE and
more

■ Thin to thick gauges

■ Technology driven
solutions!



*Turn to the leader for your
next Sheet Line project!*

PROCESSING TECHNOLOGIES, LLC
2655 White Oak Circle - Aurora, IL 60502
Ph: 630.585.5800 | Fx: 630.585.5855
www.ptiextruders.com

PRODUCTO PROGRESS BY DESIGN

Precision Thermoform Tooling

When it comes to answering your need
for quality thin gauge thermoform tooling,
you can't find a better source than
Producto.

- Complete turnkey service
- Tooling machined and assembled with precision
- Deliveries to suit your schedules
- Mold beds up to 66" x 120"
- Die sets for complex side prepunching and perimeter trim

- Engineering design using the latest CAD systems and programming Technologies
- Gun drilling services available
- Precision 5 axis machining
- Jig ground punches and dies, springs, pins & bushings and a full line of quality accessory items

Producto Corporation

800 Union Avenue,
Bridgeport, Ct 06607
Tel. (203) 367-8675 Fax (203) 368-2597
http://www.producto.com

These sponsors enable us to publish
**THERMOFORMING
QUARTERLY**

FUTURE MOLD CORP. 

215 S. Webber Street, Farwell, MI 48622
(989) 588-9948 ♦ (989) 588-6170 Fax

THERMOFORMING TOOLS
CUP LIP ROLLERS

MIKE OTTO, SALES MANAGER

www.futuremoldcorp.com
motto@futuremoldcorp.com

SELECT PLASTICS, LLC.
EXTRUDED SHEET

7224 Burns St. Metro (817) 595-3804
Fort Worth, TX 76118 FAX (817) 595-4050
(877) 501-2530

Donald H. Hudson President

 **RAY**
PRODUCTS / INC
plastics

Brian Ray
President
brianr@rayplastics.com

1700 Chablis Avenue
Ontario, CA 91761
909/390-9906
800/423-7859
FAX 909/390-9896
www.rayplastics.com

The Experts in
Thermoforming

 **TPS** THERMOFORMER
PARTS
SUPPLIERS

www.thermoformerparts.com

Great companies run in Packs
Price
Availability
Convenience
Knowledge
Call the PACK at TPS today

Thermoformer Parts Suppliers
3818 Terry Diane
Beaverton, MI 48612
Phone: 800-723-2997
Fax: 989-435-3825
Email: tps@ejourney.com

Same day shipping until 4pm EST on In-stock Items

Standex ENGRAVING GROUP  Worldwide Specialists in Textured Rolls,
Plates, Molds and Engineered Machinery

Doug Benton

Standex Engraving Group
5901 Lewis Rd.
Sandston, VA 23150

Ph: 804/236-3065
Fax: 804/226-3462

Visit the
SPE website
at
www.4spe.org

These sponsors enable us to publish **THERMOFORMING QUARTERLY**

XALOY
every pellet knows our name™

As the global leader in high-performance machinery and melt-processing components for the plastics industry, Xaloy has powerful resources to help you reduce costs and increase productivity.

BARRELS

SHUT OFF NOZZLES

HEAT TRANSFER ROLLS

HIGH PERFORMANCE SCREWS

MANUAL & HYDRAULIC SCREEN CHANGERS

PELLETIZERS

CLEANING OVENS

CONTINUOUS SCREEN CHANGERS

GEAR PUMPS

Hickory, NC
800-457-7550
T: 828-326-9888
F: 828-326-8882

New Castle, PA
800-897-2830
T: 724-656-5600
F: 724-656-5620

www.xaloy.com
info@us.xaloy.com

GAS NOT ALL IT'S FIRED UP TO BE?

Have your gas rebates run out? Are you tired of poor control, lack of uniformity & outrageous replacement costs? Retrofit today with Solar Products ELECTRIC INFRARED heaters. Custom heater technology – from America's largest supplier of infrared heaters.

Call 1-800-616-2601

For complete information visit our website at www.solarproducts.com

 **SOLAR PRODUCTS, INC.**
THE INFRARED HEATER COMPANY

STRENGTH & PRECISION

ARES ... CNC MACHINING CENTERS FOR MACHINING PLASTIC AND COMPOSITE MATERIALS



 **CMS North America, Inc.**
Grand Rapids, MI
800.225.5267 Fax: 616.698.9730

www.cmsna.com
www.cms.it
cmsales@cmsna.com

INDEX OF SPONSORS

ADVANCED VENTURES IN TECHNOLOGY, INC.	12	BROWN MACHINE	26	JRM INTERNATIONAL	5
ALCOA GLOBAL MILLS PRODUCTS	21	CMS NORTH AMERICA	31	KIEFEL TECHNOLOGY	27
ALLEN EXTRUDERS	30	CMT MATERIALS, INC.	30	KYDEX	32
AMERICAN CATALYTIC TECHNOLOGIES	23	COPPER AND BRASS DIVISION	5	LANXESS	12
AMERICAN THERMOFORMING MACHINERY	27	EDWARD D. SEGEN & CO.	28	MAAC MACHINERY	6
ALTUGLAS INTERNATIONAL	1	FOX MOR GROUP	30	McCLARIN PLASTICS	30
		FUTURE MOLD CORP.	31	MODERN MACHINERY	26
		GN PLASTICS	22	NEW HAMPSHIRE PLASTICS	18
				ONSRUD CUTTER	22
				PLASTICS CONCEPTS	23
				PLASTIMACH	26
				PORTAGE CASTING & MOLD, INC.	23
				PREMIER MATERIAL CONCEPTS	27
				PRIMEX PLASTICS	30
				PROCESSING TECHNOLOGIES ..	30
				PRODUCTIVE PLASTICS, INC.	23
				PRODUCTO CORPORATION	30
				PROFILE PLASTICS	23
				RAY PRODUCTS, INC.	31
				RAYTEK	23
				SELECT PLASTICS	31
				SENCORP	32
				SOLAR PRODUCTS	31
				STANDEX ENGRAVING GROUP ..	31
				STOPOL INC.	18
				TEMPCO ELECTRIC	4
				THERMWOOD CORP.	Inside Back Cover
				TOOLING TECHNOLOGY, LLC	4
				TPS	31
				ULTRA-METRIC TOOL CO.	28
				WECO PRODUCTS	12
				WELEX, INC.	21
				XALOY	31
				ZED INDUSTRIES	30

These sponsors enable us to publish **THERMOFORMING QUARTERLY**

SOLVE COST & PERFORMANCE PROBLEMS

◆ **Over 40 specialized grades satisfy highest performance to lowest cost applications:**

- Aircraft
- Mass transit
- Building products
- Weatherable
- Conductive/ESD
- Multi-purpose

◆ **8 Surface Textures**

◆ **Thickness from 0.028" to 0.500"**

◆ **Certified Fire Ratings:**

- UL Std. 94 V-0 and 5V
- UL 746C for signage
- FAR 25.853(a) and (d)
- Class 1/A
- MVSS 302
- ASTM E-662/E-162

◆ **Broad Color Selection:**

- 36 Standard colors
- 3000+ Custom colors
- Granite patterns
- Fluorescent colors
- Woodgrain and Abstract Designs

Kleerdex Company, LLC
6685 Low Street
Bloomsburg, PA 17815 USA
Tel: 1.800.325.3133
Fax: 1.800.452.0155
E-mail: info@kleerdex.com
www.kydex.com

KYDEX[®]
THERMOPLASTIC SHEET
ISO 9001:2000 and
ISO 14001 CERTIFIED



SENCORP[™]

Thermoformers

Special Machines | Clamshell Sealers | Blister Sealers | Laboratory Sealers

Sencorp thermoformers deliver repeatable, quality production parts at high cycle speeds. Available options include closed loop thermal imaging sheet scanning, adjustable shut height, deep draw, quick changeover master tooling and robotic part removal systems. Sencorp thermoformers provide you with a competitive edge over your competition.



We build machines that build business

400 Kidds Hill Road—Hyannis, MA 02601—USA
P: 508-771-9400 F: 508-790-0002 E: sales@sencorp-inc.com www.sencorp-inc.com



2007: A Year to Nurture Future Leadership

My Hard-Charging New Year's Resolutions

It's that time of the year again ... for New Year's Resolutions. As usual, mine focus on health and fitness. Unfortunately, I find myself looking back with dismay at my unfinished 2006 personal resolutions. Too little physical activity. Not much movement on the weight loss front! But with a renewed sense of vigor, I'm charging hard into 2007!

But in addition to personal resolutions, I also made three SPE Thermoforming resolutions. As your new Chairman ...

- I resolve to guide your organization with the integrity and energy you expect.
- I resolve to bring continuing relevance to your organization through conferences, seminars, technical information and networking opportunities.
- And – most importantly – I resolve to nurture new people for your organization's leadership.

Currently, we are blessed with an incredibly capable group of professionals who are extremely generous with their time. And, by the time you read this, you will already have voted on an outstanding slate of 2007 candidates to the Board of Directors.

But my "leadership" resolution is really about planting and germinating the seeds of interest in 2007 and harvesting Division leadership for 2008 and beyond. To each of you, I ask: *Have you ever considered joining the Board of Directors to help plan and execute the many initiatives of your organization?*

My Challenge to You

Take it from me – from someone who's been involved in Thermoforming Division leadership for a number of years – it is extremely rewarding and gratifying to give back to my vocation.

Every day we "take, take, take" from the thermoforming industry; after all it's where we derive our livelihood. So, I challenge you – especially the thin- and heavy-gauge thermoformers – to get involved. Consider "giving back" to your industry through Board leadership. Each year one-third of our Board members either rotates off or is up for reelection, so each year there are a number of new openings. We especially need a few more practicing thermoformers interested in Board membership.

Please don't be shy. If you would like to know more about Board activities, I encourage you to contact a current or past Board member ... someone you may know, someone in your industry or someone in your geographic area. They would be

delighted to talk with you about what Board membership means to them and the duties involved.

To All Members: Cultivate and Nourish Potential Leadership

But wait, there's more to my resolution. This leadership appeal wouldn't be complete without also asking ALL members to cultivate and encourage others to consider a leadership position. Nine times out of ten, people don't get involved unless they're asked. So, ask. Ask the best and the brightest you know. Or contact an existing Board member with a name, so we can begin nourishing that leadership relationship.

Thank You, Jim Throne

Long-time technical editor of *Thermoforming Quarterly*, Jim Throne (Sherwood Technologies, Inc.), has put down his pen and retired from his editing duties. Author of several books, Jim generously shared with us his deep knowledge of the thermoforming industry for many, many years. Thank you, Jim, for your true dedicated service. You'll be much missed. Picking up Jim's mighty-mantle is Board Chair-Elect Barry Shepherd of Shepherd Thermoforming & Packaging, Inc. in Ontario. Welcome, Barry!

2007 Conference Planning Underway

At our February Board meeting, we'll be reviewing the agenda for our upcoming conference in Cincinnati from September 16th-19th, 2007. Conference Chairman Ken Griep and Technical Co-Chairs Conor Carlin, Brian Winton, and Haydn Forward will be presenting the upcoming conference agenda. We'll also be talking about our 2008 Minneapolis Conference, plus a possible alternative to our 2009 Conference. There has been some interest in holding several regional one-day technical sessions across the country to provide professional development opportunities to more people.

Is a European Conference in Our Future?

Also at the February Board meeting, we'll be discussing a possible joint conference with the European Thermoforming Division. It's a very small world today. Perhaps there's some value in sharing a conference date, exploring common global issues and industry challenges. There is much to explore and debate. What do you think?

Happy New Year!

Finally, I wish all of you a healthy and prosperous new year. And, if you're interested in taking up my leadership challenge, give me a call!

It's a great day in thermoforming!

Walt Walker

James A. Alongi - 2009
MAAC Machinery
590 Tower Boulevard
Carol Stream, IL 60188-9426
TEL (630) 665-1700
FAX (630) 665-7799
jalongi@maacmachinery.com
Machinery Committee

Jim Armor - 2008
Armor & Associates
16181 Santa Barbara Lane
Huntington Beach, CA 92649
TEL (714) 846-7000
FAX (714) 846-7001
jimarmor@aol.com
Materials Committee

Phil S. Barhouse - 2009
Creative Forming
100 Creative Way
P.O. Box 128
Ripon, WI 54971
TEL (920) 748-1119
FAX (920) 748-9466
phil.barhouse@creativeforming.com
Materials Committee

Michael Book - 2007
6259 Rime Village Dr. Apt. 208
Huntsville, AL 35806
TEL (256) 230-5442
michaelbook@hotmail.com
Processing Committee

Arthur Buckel - 2008
McConnell Co., Inc.
3452 Bayonne Drive
San Diego, CA 92109
TEL (858) 273-9620
FAX (858) 273-6837
artbuckel@thermoforming.com
Processing Committee

Conor Carlin - 2008
Stopol, Inc.
31875 Solon Road
Solon, OH 44139
TEL (440) 498-4000
FAX (440) 498-4001
conorc@stopol.com
Machinery Committee

Haydn Forward - 2009
Specialty Mfg., Inc.
6790 Nancy Ridge Drive
San Diego, CA 92121
TEL (858) 450-1591
FAX (858) 450-0400
hforward@smi-mfg.com
Processing Committee

Roger Fox - 2007
The Foxmor Group
373 South County Farm Road
Suite 202
Wheaton, IL 60187
TEL (630) 653-2200
FAX (630) 653-1474
rfox@foxmor.com
Marketing Committee

Richard Freeman - 2009
Freetech Plastics
2211 Warm Springs Court
Fremont, CA 94539
TEL (510) 651-9996
FAX (510) 651-9917
rfree@freetechplastics.com
Processing Committee

Hal Gilham - 2007
Productive Plastics, Inc.
103 West Park Drive
Mt. Laurel, NJ 08045
TEL (856) 778-4300
FAX (856) 234-3310
halg@productiveplastics.com
Processing Committee

Ken Griep - 2008
Portage Casting & Mold, Inc.
2901 Portage Road
Portage, WI 53901
TEL (608) 742-7137
FAX (608) 742-2199
ken@pcmwi.com
Machinery Committee

Steve Hasselbach - 2008
CMI Plastics
P.O. Box 369
Cranbury, NJ 08512-0369
TEL (609) 395-1920
FAX (609) 395-0981
steve@cmiplastics.com

Donald C. Hylton - 2007
646 Holyfield Highway
Fairburn, GA 30213
TEL (678) 772-5008
don@thermoforming.com
Materials Committee

Bill Kent - 2008
Brown Machine
330 North Ross Street
Beaverton, MI 48612-0434
TEL (989) 435-7741
FAX (989) 435-2821
bill.kent@brown-machine.com
Machinery Committee

Don Kruschke - 2007
Stopol, Inc.
31875 Solon Road
Solon, OH 44139
TEL (440) 498-4000
FAX (440) 498-4001
donk@stopol.com
Machinery Committee

Mike Lowery - 2007
Premier Plastics
9680 S. Oakwood Park Dr.
Franklin, WI 53132
TEL (414) 423-5940 Ext 102
FAX (414) 423-5930
mikel@lowerytech.com
Processing Committee

Wm. K. McConnell, Jr. - 2008
McConnell Co., Inc.
3030 Sandage St.
P.O. Box 11512
Fort Worth, TX 76110
TEL (817) 926-8287
FAX (817) 926-8298
billmc@thermoforming.com
Materials Committee

Vin McElhone - 2007
Stand-Up Plastics
5 Fordham Trail
Old Saybrook, CT 06475
TEL (860) 395-5699
FAX (860) 395-4732
vin@standupplastics.com
Materials Committee

Stephen R. Murrill - 2009
Profile Plastics Corp.
65 S. Waukegan
Lake Bluff, IL 60044
TEL (847) 604-5100 EXT. 29
FAX (847) 604-8030
SMurrill@thermoform.com
Processing Committee

Dennis Northrop - 2009
Avery Dennison
Automotive Division
650 W. 67th Avenue
Schererville, IN 46375-1390
TEL (219) 322-5030
FAX (219) 322-2623
Dennis.Northrop@averydennison.com
Materials Committee

Joe Peters - 2007
Universal Plastics
75 Whiting Farms Road
Holyoke, MA 01040
TEL (413) 592-4791
FAX (413) 592-6876
petersj@universalplastics.com
Processing Committee

Laura Pichon - 2008
Ex-Tech Plastics
P.O. Box 576
11413 Burlington Road
Richmond, IL 60071
TEL (847) 829-8124
FAX (815) 678-4248
lpichon@extechplastics.com
Materials Committee

Robert G. Porsche - 2009
General Plastics, Inc.
2609 West Mill Road
Milwaukee, WI 53209
TEL (414) 351-1000
FAX (414) 351-1284
bob@genplas.com
Processing Committee

Walt Speck - 2007
Speck Plastics, Inc.
P. O. Box 421
Nazareth, PA 18064
TEL (610) 759-1807
FAX (610) 759-3916
wspeck@speckplastics.com
Processing Committee

Dr. Martin J. Stephenson, Ph.D. - 2009
316 Boulevard Ave.
Belleville, WI 53508
TEL (608) 424-3837
dezmar@hotmail.com
Materials Committee

Jay Waddell - 2008
Plastic Concepts & Innovations, LLC
1127 Queensborough Blvd.
Suite 102
Mt. Pleasant, SC 29464
TEL (843) 971-7833
FAX (843) 216-6151
jwaddell@plasticconcepts.com
Processing Committee

Brian Winton - 2007
Modern Machinery
P. O. Box 423
Beaverton, MI 48612-0423
TEL (989) 435-9071
FAX (989) 435-3940
bwinton@modernmachineinc.com
Machinery Committee

These sponsors enable us to publish **THERMOFORMING QUARTERLY**

Thermwood CNC...the Safe Choice

Everything from one Company

5 Axis Moving Table Machines
Single and Dual Tables
5x5', 5x10' or 5x12'

- Broad Line of CNC Routers
- Name Brand Tooling
- Machine Supplies
- Software and Support
- Training
- Virtual Service
- Advanced Support Program

www.thermwood.com
P.O. Box 436, Dale, IN 47523 800-533-6901

THERMWOOD
First in CNC Routers