



Thermoforming Quarterly®

First Quarter 2017 | Volume 36 | Number 1

A Journal of the Thermoforming Division of the Society of Plastics Engineers



Starting Early: Workforce Development in Plastics

IN THIS ISSUE:

*McKinsey on Workforce
Development*

*Thermoformed Packaging
in SE Asia*

*Heating the Sagging
Sheet*

A stone bridge spans across a body of water. The bridge is made of large, rough-hewn stones. In the background, there are more rocks and a clear blue sky. Overlaid on the scene are numerous colorful, glowing light trails in shades of red, orange, yellow, green, and blue, which appear to be moving across the bridge and the water, suggesting speed and modern technology.

Composite, Fiberglass, SMC,
Painted Metal, Painted RIM, Injection molded plastics

We all compete with **old** thinking.

PARTNER WITH US TO CREATE NEW OPPORTUNITIES

When material suppliers and thermoformers collaborate early in a project lifecycle we both get more business. Join our mission to promote and educate OEMs about the benefits of thermoplastics and the thermoforming process.

Contact us today at thermoforming@sekisui-spi.com

SEKISUI | SPI

KYDEX
THERMOPLASTICS

ALLEN
THERMOPLASTICS

designLab

FSTLab

1.800.325.3133 | info@sekisui-spi.com | sekisui-spi.com

■ Departments

Chairman's Corner | 4

New Members | 5-6

Thermoforming in the News | 8-12

University News | 14-15

■ Features

North American Plastics Industry Survey
2016 Report | 16-18

Closing the Skills Gap: Creating Workforce Development
Programs that Work for Everyone | 20-24

Thermoforming 2.0: Heating the Sagging Sheet | 26-27

Lead Technical Article: The Production of Drinking
Cups, Part 2 | 28-37

Global Dispatches: Innovation Before Technology | 38-43

■ In This Issue

In Memoriam: Stephen J. Sweig | 44

SPE Council Report | 46



Cover photograph courtesy of Penn College

A JOURNAL PUBLISHED EACH
CALENDAR QUARTER BY THE
THERMOFORMING DIVISION
OF THE SOCIETY OF
PLASTICS ENGINEERS

Editor

Conor Carlin

(617) 771-3321

cpcarlin@gmail.com

Sponsorships

Lesley Kyle

(914) 671-9524

lesley@openmindworks.com

Conference Coordinator

Lesley Kyle

(914) 671-9524

lesley@openmindworks.com

SPE Thermoforming Quarterly® is published four times annually as an informational and educational bulletin to the members of the Society of Plastics Engineers, Thermoforming Division, and the thermoforming industry. The name, "**SPE Thermoforming Quarterly**"® and its logotype, are registered trademarks of the Thermoforming Division of the Society of Plastics Engineers, Inc. No part of this publication may be reproduced in any form or by any means without prior written permission of the publisher, copyright holder. Opinions of the authors are their own, and the publishers cannot be held responsible for opinions or representations of the authors. Printed in the U.S.A.

SPE Thermoforming Quarterly® is registered in the U.S. Patent and Trademark Office (Registration no. 2,229,747). |

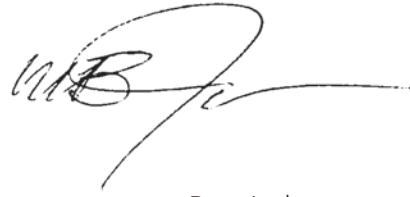

Bret Joslyn



2017: A Milestone Year

2017 is a milestone year as SPE celebrates its 75th anniversary. This is no ordinary accomplishment when you consider how rapidly things have changed in the world of plastics and polymers in only the past fifteen years. The Thermoforming Division recently concluded its first board meeting of the year with a renewed commitment to active participation in our society at large. At ANTEC (Anaheim, May 8 -10), division representatives will moderate a thermoforming technical session that Wednesday morning. Our Division also plans to sponsor a student reception during ANTEC week as well.

As our members will certainly agree, engaging the next generation of plastics professionals is a critical element of our mission (see article on pp. 20-24). In addition to the student event described above, the division will participate in the NextGen Advisory Board (NGAB) event which starts the week in Anaheim. The goal is to have more intimate discussions on expectations of the industry, where we think it is going, and how to engage the younger generation of thermoformers that are up and coming.

Our most recent board meeting also focused on preliminary plans for the Orlando Conference (Sept. 9-11). The speaker schedule is being refined and should be finalized by early May. This year, instead of hosting

a Student Parts Competition, there will be a sponsored Student RC Car Race. Participants will thermoform custom car bodies and races will be held during the conference. Breakout sessions during the Board meeting highlighted a strategic discussion to truly engage membership and to identify topics that members would like to see included at the conference as well as in the Quarterly. We are all inundated with inquiries, but I do sincerely hope that you can take some time to get in touch with us if there are areas of interest you would like to see covered more in depth.

This issue of TQ offers readers a glimpse into thin wall packaging in Southeast Asia, a very interesting and dynamic part of the world (pp. 38-43). Closer to home, our good friends at Penn College in Williamsport, PA hosted a wonderful day of plastics education in conjunction with the SPE PlastiVan™ Educational Outreach Program (pp. 14-15). Several thermoformers have sponsored the PlastiVan in their areas. If you haven't already done so, I highly recommend that you contact Eve Vitale, SPE Foundation Director for more details. The testimonials from teachers, parents, local businesses and, most importantly, the students themselves, will convince you of the value of this excellent educational program.

We hope to see you at ANTEC in the spring. |

Have an idea for an article?

Submission Guidelines

- We are a technical journal. We strive for objective, technical articles that help advance our readers' understanding of thermoforming (process, tooling, machinery, ancillary services); in other words, no commercials.

- Article length: 1,000 - 2,000 words. Look to past articles for guidance.
- Format: .doc or .docx Artwork: hi-res images are encouraged (300 dpi) with appropriate credits.

Send all submissions to Conor Carlin, Editor, at cpcarlin@gmail.com

New Members

John Albers
Greenwood Plastics Ind.
Danville, IL

Beddome Allen
PATH
Seattle, WA

Francisco Alvarez
Milliken & Company
Spartanburg, SC

Keith Anderson
T.O. Plastics
Clearwater, MN

Mike Angell
Sekisui SPI
Holland, MI

Sammy Arriaga
Tek Pak, Inc.
Batavia, IL

Paul Aucoin
ACIP/CPIA (Canadian
Plastics Industry
Association)
QC

Jay Baker
Jamestown Plastics
Brocton, NY

Jessup Baker
Jamestown Plastics
Brocton, NY

Nate Beardsley
KL Outdoor
Muskegon, MI

Greg Belle Isle
Wilbert Plastic Services
White Bear Lake, MN

Grant Bennett
Polyvisions Inc.
Manchester, PA

Ted Bevelheimer
Sekisui SPI
Bloomsburg, PA

Tiffany Blanchard
Think4D
Altona, MB

Carri Boyd
American Wick Drain
Monroe, NC

Sam Butler
Neocon
Dartmouth, NS

Danielle Campbell
Nuvar Inc.
Holland, MI

Ben Carter
Tek Pak, Inc.
Batavia, IL

Willie Carter
Tek Pak, Inc.
Batavia, IL

Patrick Castro
Electro-General Plastics
Corp. of Columbus
Grove City, OH

Andre Comino
Brudden Equipamentos
Sao Paulo, Brazil

Sam Cooper
PolyJohn Enterprises
Whiting, IN

Chad Coulson
Sportech
Elk River, MN

Dennis Curry
CK Technologies, LLC
Montpelier, OH

John Davidson
Distortion Arts, LLC
LaValle, WI

Ryan Faoro
Profile Plastics Inc.
Lake Bluff, IL

Jason Glazier
Erwin Hymer Group
Kitchener, ON

Tom Goldblatt
Goldblatt & Associates
Wilmette, IL

Eric Grenell
KL Outdoor
Muskegon, MI

Melissa Griggs
Bostik Inc
Beverly Hills, MI

Justin Harris
KL Outdoor
Muskegon, MI

Kevin Henry
KMAK Group LLC
London, OH

Jonathan Jackson
Rapac, Lp
Oakland, TN

Jeffrey Jobe
Innovative Plastech, Inc.
Batavia, IL

Patrick Johnsen
Graham Engineering
York, PA

Travis Klewec
Brentwood Industries
Reading, PA

Barbara Kline
Brentwood Industries
Reading, PA

Dennis Koerne
RING Companies
Oakland, TN

Kazu Kuda
FujiFilm
Hanover Park, IL

Michelle Lamontagne-
Condon
Klockner Pentaplast
Gordonsville, VA

Desiree Lewars
Brentwood Industries
Reading, PA

Maureen Linhardt
Profile Plastics Inc.
Lake Bluff, IL

Zac MacKay
TASUS
Hamilton, ON

Jim Martin
Future Mold Corp.
Farwell, MI

Paul McKinley
Wilbert Plastic Services
White Bear Lake, MN

Jim McVicar
PMC
Findlay, OH

Pascale Misslin
Protechnic
Cernay, France

Craig Moore
mmcc
Beaverton, MI

Key Nishimura
Brudden Equipamentos
Sao Paulo, Brazil

Matt Owen
Ameriform Aquisitions
Muskegon, MI

Gerry Pike
Neocon
Dartmouth, NS

Brian Reniker
Select Plastics
Fort Worth, TX

Martin Rivard
Pelican International Inc.
Laval, Canada

Angela Rodenburgh
Ladder Up
Vancouver, BC

Chris Ryan
Chemspec Ltd.
Ravenna, OH

Kathy Saint
Schwerdtle Technologies
Bridgeport, CT

Chris Scott
Tek Pak, Inc.
Batavia, IL

Miguel Serrano
General Motors
Mexico

Lance Simmons
Plastics Unlimited
Preston, IA

Andrew Sneeringer
Signature Systems Group
St. Cloud, FL

Darrell Stafford
Catalysis - Additive
Tooling
Powell, OH

Jillian Steffek
Oshkosh Corporation
Oshkosh, WI

Seth Stewart
Klockner Pentaplast
Charlottesville, VA

Edwin Tam
Teknor Apex Company
Pawtucket, RI

Gian Tan
Ride Inc.
Quezon City, Phillipines

Gwendoleen Tan
Ride Inc,
Quezon City, Phillipines

Jim Throne
Sherwood Technologies
Dunedin, FL

Eric Toussaint
Pattison Sign Group
Edmundston, NB

Rick Turman
Reliable Formed Plastics
Birmingham, AL

Trevor Vranj
Tek Pak, Inc.
Batavia, IL

Joshua Wakeford
American Standard
Brands Salem. OH

Mark Wessell
Lexaform
Rogersville, MO

Fred Whitmire
Brentwood Industries
Reading, PA

Jay Yohn
Brentwood Industries
Reading, PA

Changcheng Zhu
PATH
Seattle, WA



WHAT DOES TPO NEED?

- UNIFORMITY**
- CONTROL**
- REPEATABILITY**

Retrofit Today with Solar Products **ELECTRIC INFRARED** heaters.
Custom heater technology – from America's largest supplier of infrared heaters.



SOLAR PRODUCTS, INC.
THE INFRARED HEATER COMPANY

Call 1-800-616-2601
For complete information visit our website at www.solarproducts.com

Thermoformer Parts Suppliers



TINSEL STATIC METER VORTEX BLOWER

TAKK Model 400T Ion Edge AC Static Eliminator Bar CURTAIN AIR IONIZER

Are you tired of getting a CHARGE out of your plastic sheets?
Introducing the TAAK line of Anti-Static Products for your Thermoformer!

*****NOW BUY ONLINE AT: *****
WWW.THERMOFORMERPARTS.COM
1-800-722-2997
3818 Terry Diane, Beaverton, MI 48612
Ph: (989) 435-3800 Fax: (989)435-3825



THERMOFORMING

Become a SPE Thermoforming Quarterly Sponsor in 2017!

Sponsorship opportunities include
4-color, full page, and 1/2 page ad spaces.

RESERVE YOUR PRIME SPONSORSHIP SPACE TODAY.

Questions? Call or email Lesley Kyle
914-671-9524 lesley@openmindworks.com

GN

Thermoforming Equipment

NEW GN800

Form/Cut/Stack model

*The latest addition to our line
of GN Thermoformers*



- Forming 150mm above and below sheet line
- High efficiency heaters
- Clamping force of 75 tons in form and cut stations
- In-mould-cut capability
- Various stacking systems
- Multi-purpose thermoformer for food, medical, industrial and other special applications

www.gncanada.com

Award-Winning Twist Cup Doubles up on Resins and Plastic Technologies

by *Plastics Today*

JANUARY 9, 2017 – An innovative packaging solution from RPC Superfos (Lidköping, Sweden) and RPC Promens (Moss, Norway) for a range of premium cold salads from Orkla Foods Norway (Oslo) has been awarded a WorldStar 2017 in the international packaging competition.

The pack successfully mixes two different resin materials and two different technologies to create a thermoformed twist cup with an injection-molded lid. The result has similarities with a traditional glass jar that makes it stand out in the cold salad segment.

Despite the challenges that come from using two different resin materials, compatibility between the thermoformed polyethylene body and the injection-molded propylene lid was achieved.

The lid latches into the locking groove of the cup and, when closed correctly, permits the consumer to hear a comforting click-sound that confirms the seal.

Orkla Foods Norway entrusted RPC Superfos Lidköping (Sweden) and RPC Promens Kambo (Norway) with the assignment to develop an out-of-the-ordinary pack to emphasize the high-end appeal of their salads. "It is a major accolade to receive a WorldStar and we are all very pleased, not least because the award acknowledges a project for which we combined the capabilities and technologies of both RPC Superfos and RPC Promens," comments Thomas Winkler, area sales manager at RPC Superfos Lidköping.

"We are proud to get the positive attention which comes with a WorldStar award," adds Tore Lund, senior project engineer, RPC Promens Kambo. "It has been a privilege to cooperate with Orkla Foods Norway and to get the opportunity to demonstrate our innovative expertise." The Twist Cup with screw lid qualified for the WorldStar competition after its winning of a ScanStar 2016 in the Nordic Packaging competition. It was also shortlisted for the Danish FoodTech Award 2016.

Organized by the World Packaging Organisation (WPO) the WorldStar Competition is the pre-eminent international award in packaging. The 2017 Awards presentation



ceremony takes place during Interpack 2017 in Düsseldorf, Germany in May.

New Distributor for CMT Materials in Australia and New Zealand

by *Clare Goldsberry, Plastics Today*

FEBRUARY 1, 2017 – CMT Materials Inc. (Attleboro, MA) has announced a new partnership with Phillip Shelton Tooling Pty Ltd. of Australia to distribute the Hytac line of syntactic foam plug assist materials for thermoforming.

"We are very pleased to welcome Phil to our global network," said Conor Carlin, Sales and Marketing Manager for the company. "Phil has a deep understanding of both toolmaking and thermoforming, which makes him an ideal partner for us in the Oceania region."

Phillip Shelton is a qualified toolmaker with 40 years' experience in plastics processing. He has provided consultancy services including product design, mold design and project management for the manufacture of food packaging using both thermoforming and injection

molding processes. He has worked with major companies from concept to tool design to full-scale production.

Shelton commented, "I'm very much looking forward to working with the team at CMT. They have proven to be the global leader in plug assist materials for many years."

CMT Materials specializes in the design and development of syntactic foams. The innovative Hytac family of products has been designed specifically for the thermoforming industry. Plug-assist technology allows plastics processors to reduce starting gauge and cycle times and improve material distribution.

SCGM Set to Begin Construction of RM54mil Facility

by *The Star Online*

FEBRUARY 8, 2017 – SCGM Bhd, a thermoform food packaging manufacturer, is set to start building its new RM54mil (USD\$12MM) manufacturing facility in Kulai, Johor.

The facility, spread over 7.8ha, is located about 5km from the company's existing premises and scheduled for completion in December 2018.

In a statement on Wednesday, managing director Datuk Seri Lee Hock Chai said the enlarged production floor space and new machinery at the facility, would bump up the group's extrusion capacity by 73% to 62.6 million kg per year from the current 36.0 million.

"As a major producer of thermoform packaging for food and beverages, SCGM has been among the key beneficiaries of higher demand in the past year with the regulatory ban on polystyrene products in Malaysia.

"In the near future, we foresee a second wave of uptrend in demand alongside public awareness of food safety and environmental sustainability, not only in the local market but also increasingly in the Asia-Pacific region," he added.

Lee said he was optimistic that the larger production capacity accorded by the new factory would place SCGM on a steady growth path to meet current and future demand.

The group has earmarked RM125mil (USD\$28.1MM) in total

capital expenditure for the new factory, encompassing land acquisition, building construction and purchase of new machinery.

RPC Buys Rochester-based Letica in Deal Valued at \$640 million

by *Jim Johnson, Plastics News*

FEBRUARY 9, 2017 – The buying spree continues, and this time RPC Group plc is bulking up in the United States with a deal for Rochester-based Letica Corp.

A deal valued at up to \$640 million adds 13 plants that make rigid plastic packaging and food service products and 1,750 employees. They will join five existing RPC facilities in the United States.

RPC has now made deals for six companies since the end of September.

Letica helps propel RPC deeper in to the United States as CEO Pim Vervaat continues to push the company's growth strategy outside of Europe.

It was less than three years ago that Vervaat sat in a small conference room at the company's manufacturing site in Morgantown, a small town in eastern Pennsylvania, and shared some of his vision for RPC's growth in the United States.

"We're not in it to become the biggest packaging company in the world. We're not in it to become the biggest packaging company in the U.S. But we do have certain capabilities where we can follow our customers sensibly into the U.S.," he said at the time.

"We are thinking that the U.S. is quite important for us," Vervaat said when the company was unveiling a \$10 million expansion of the site.

Letica, which will be a stand-alone business within RPC's Superfos division, brings \$450 million in annual sales to RPC and adjusted earnings before interest, taxes, depreciation and amortization of \$57 million. RPC is paying an earnings multiple of 8.5 as \$490 million will be paid to shareholders initially. The deal also includes an ability to earn another \$150 million based on the company's future profit.

"The acquisition of Letica provides a unique opportunity to further extend RPC's geographical reach into the attractive North American market through Letica's strong and well-invested manufacturing footprint," Vervaat said in a statement. "We are excited to be able to develop an enhanced platform of scale to support continued organic and inorganic growth in the United States."

RPC already has identified \$12 million in annual savings by purchasing Letica, which has its locations in nine states. Letica makes products a variety of ways, including injection molding, thermoforming and sheet extrusion. The company's food service packaging business includes both plastic and paper products.

CEO Anton Letica and Vice President of Operations Mara Letica will stay with the company, at least until the end of the company's current financial period, to help with the transition and customer relationships, RPC said.

Letica ranked 16th on Plastics News' most recent survey of North American injection molders. RPC ranked No. 2 in Plastics News Europe's most recent listing of Europe's top rigid plastics packaging producers.

Octal Mulls IPO by 2019

by *Plastemart.com*

FEBRUARY 13, 2017 – Octal, a US\$650 mln petrochemical project in Oman, is eyeing an initial public offering by 2019 as it expands its facilities globally to cater to a growing clientele for its plastics products, according to company officials in thenational.ae. Octal, which was set up in 2006 in the southern port city of Salalah, is spending US\$110 mln over a five-year period to produce new products, add capacity and expand its footprint into regions such as South America, according to Nicholas Barakat, the company's chief executive. With regards to the IPO, the company has not finalized plans for size or location. Octal has in the past relied on loans and its own resources to fund expansion.

"We look at different scenarios," Mr Barakat said. "Markets are very fluid now in the Middle East. With the numbers we have, we qualify to float from Hong Kong to Tokyo to New York."

The company's current capacity is 1 million tonnes a year of petrochemicals from plants in Salalah, the US and Saudi Arabia, 98 per cent of which is exported, with the US taking the lion's share. The new capacity has not been finalized yet as the company mulls adding capacity from a new

undisclosed location. "The objective here is to continue to invest in our asset base to produce more products out of the same machines," said William Barenberg Jr, the executive vice president and chief operating officer. "The other part is to incrementally add capacity this year aggressively both in Salalah and in Cincinnati in the USA."

Sonoco Products buying Peninsula Packaging

by *Jim Johnson, Plastics News*

FEBRUARY 16, 2017 – Sonoco Products Co. is acquiring thermoformer Peninsula Packaging Co. LLC in a \$230 million all-cash deal.

The move nearly doubles Sonoco's thermoforming business.

Peninsula, owned by Odyssey Investment Partners LLC, makes fresh fruit and vegetable packaging found in grocery stores.

Exeter, Calif.-based Peninsula has five manufacturing sites and estimates its 2016 proforma sales at \$190 million. That includes projected full-year sales from a new operation in Mexico that started in mid-year 2016.

"Our goal has been to strategically expand our consumer packaging portfolio to grow our offerings in both the center of the store and the fast growing perimeter," Sonoco CEO Jack Sanders said in a statement.

"With the addition of Peninsula, Sonoco will nearly double its thermoforming packaging capabilities and occupy a strong packaging position serving the perimeter in fresh food products, combined with our existing offerings in the center of the store, including those serving a range of frozen and shelf-stable foods," he continued.

Peninsula's business is based on using recycled PET bottles to serve as a feedstock for its new thermoformed packaging.

"We are the largest single user of recycled washed bottle flake in North America, converting this material into food-contact quality products for re-use by our customers," the company says on its website. Sonoco, based in Hartsville, S.C., also has a recycling division.

Peninsula uses 70 million pounds of recycled PET each year, the company said.

It's either you
or your competitor!



RM77 „REVOLVER“

The fastest on the draw

World record in PP cups:
54 cycles per minute

Thermoforming In The News

Peninsula also noted that it operates one of the largest private solar panel farms in North America next to its Exeter location. That site produces up to 1 megawatt of power each day.

Sonoco's push further into thermoforming comes at a time when the perimeter of grocery stores — where fresh food is typically displayed — is growing in consumer popularity.

The purchase positions Sonoco to capture growth in the fresh and natural category and allows the company to offer a wider array of packaging, Sonoco said.

Christopher Manuel, a senior analyst with Wells Fargo Securities, called the acquisition "a nice fit, and at a reasonable price" for Sonoco. He estimated the purchase price at 8 to 8.5 times earnings before interest, taxes, depreciation and amortization.



Adding Peninsula Packaging Co. LLC to Sonoco Products Co.'s operations will nearly double its thermoforming operations, with a focus on fresh produce.

Peninsula, which had actual 2016 sales of \$175 million, has production facilities in Yakima, Wash.; Hollister and Exeter, Calif.; and Wilson, N.C., as well as a new facility opened last year in El Salto, Mexico. The company's products include hinged containers, bases, lids and domes for primary markets including berries, packaged salads and cut vegetables. It employs 700 and has 36 thermoforming machines.

Sonoco has 13 thermoforming plants and thermoforming sales of \$270 million, according to *Plastics News* estimates.

The deal is expected to close in the second quarter. |

Follow
SPE Thermoforming
Division on Twitter!



@SPEThermo

Why Join?



It has never been more important to be a member of your professional society than now, in the current climate of change and global growth in the plastics industry. Now, more than ever, the information you access and the personal networks you create can and will directly impact your future and your career.

Active membership in SPE – keeps you current, keeps you informed, and keeps you connected.

The question really
isn't "why join?"
but ...

Why Not?



creativitylab.it

Since 1965, our mission:

The design and manufacture of the most advanced and energy efficient thermoforming machines in the world, for the processing of thermoplastic materials.

O.M.G. srl currently offers a wide variety of standard series machines for both thin and heavy gauge applications, as well as highly customized complete packaging lines, and custom thermoforming systems.

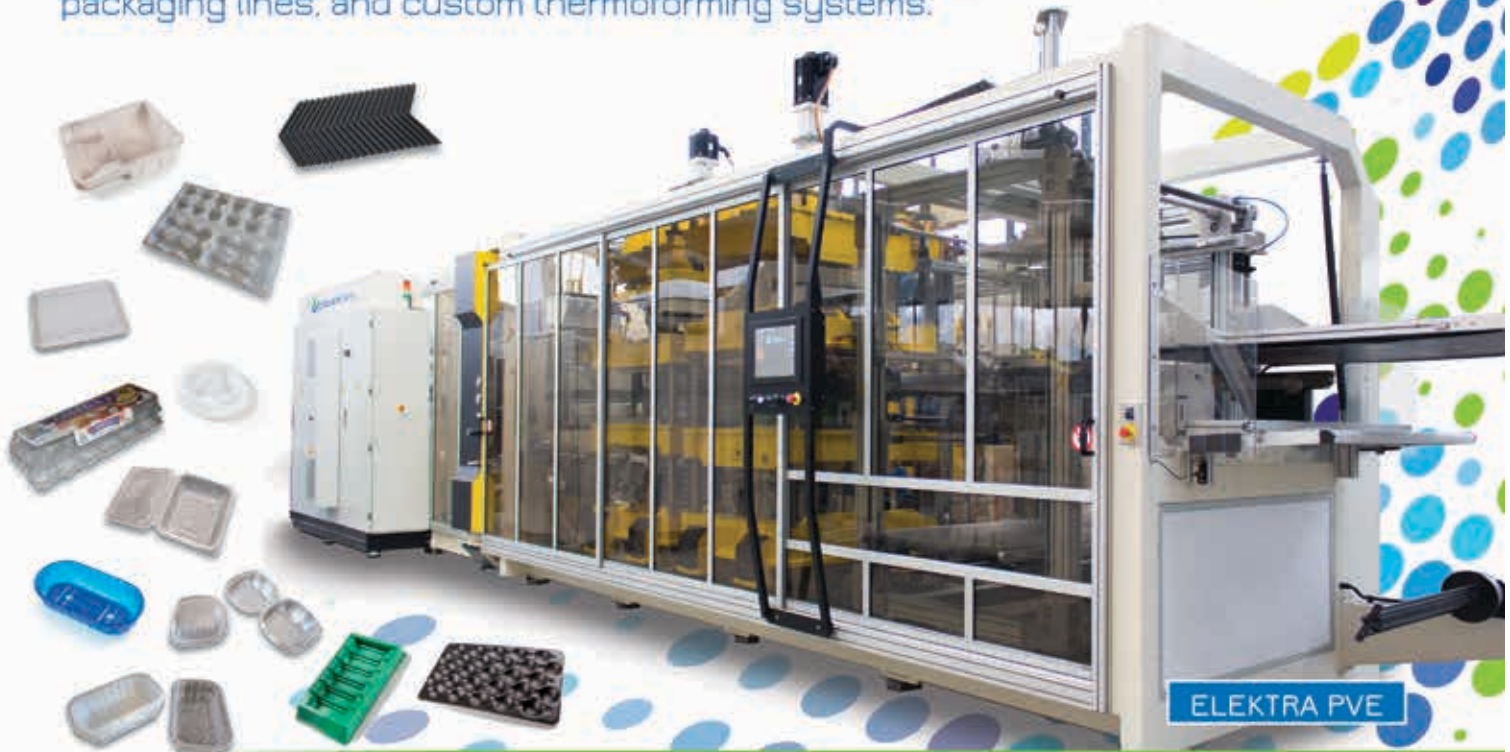

ENERGY EFFICIENT, ALL ELECTRIC SERVO DRIVE MOVEMENTS

From large to small size inline machines, Cut-in-place machines, to custom thermoforming lines and systems for the processing of all types of thermoformable plastics, including PET, PLA, PS, PPEVOH, OPS, HIPS, EPS, PE, PVC, PC, PE, HDPE and many more...

O.M.G. can provide a cost effective solution for your everyday challenges!!

OPTIONS:

Edge preheater system, drum pre-heaters for running PP, material grinders, cut-in-place presses, punch & die presses, additional modules for after the press automation, single or double sided A/B stacking robots, complete tooling packages and much more..

Call O.M.G. for all your thermoforming application needs!!

Italian
Experience &
Technology
in the world



O.M.G. srl - ITALY
10040 Givoletto (To)
Tel. +39 (011) 9947156
info@omgitaly.com

O.M.G. USA
Paxton, Ma 01612
Tel. +1 (508) 7521457
pietro.caiani@omgusa.net

O.M.G.: your next thermoforming machine!

WWW.OMGITALY.COM

Touring PlastiVan Exposes Today's Students to Tomorrow's Careers

The traditional gift for a 20th anniversary is china, but for a traveling educational exhibit in its second decade of reaching students from 5th to 12th grades, the operative material is plastics.

The Society of Plastics Engineers' PlastiVan™ program recently visited Pennsylvania College of Technology in Williamsport, as well as two area schools, providing nearly 2,000 students with a hands-on opportunity to explore rewarding and high-paying careers in manufacturing.

The visit was sponsored by Sekisui SPI, of Bloomsburg, PA, which has also established two \$7,000 scholarships for the Fall 2017 semester at Penn College.

"A lot of us who have been involved with SPE and plastics in general look around and we see that we're all graying, and it's hard to get students to understand the opportunity," SPE Foundation Director Eve Vitale said. "There's a lot of STEM education and so they say, 'Well, I'm going to be a nurse or a doctor or an engineer,' but they don't realize that the plastics industry very specifically needs help. And they don't understand the depth or the breadth of things they could do."

In addition to explaining the structure and history of polymers, including such innovations as sodium polyacrylate (the absorbent gel in disposable diapers), nylon, Kevlar – even the green slime popularized in "Ghostbusters" – the students get a literal feel for the field of plastics.

"One way to really, really engage students is to get them doing hands-on things

right away," Vitale said, "because that's a fun way to learn and it shows them what their world can be like."

And whether a chemistry student visiting a college lab or a Girl Scout working on a STEM project, that world is wide open.

"They can be polymer scientists, they can be chemists and they can work on really cool, new materials. They can work on the design of things, they can work in the automotive industry, they can design things for our cars that make us safer," Vitale said, expanding that list with the near-endless possibilities involving such familiar items as games, phones and sports equipment.

"If they are really interested in how things are made, we need really good talent in manufacturing plants to make those processes run smoothly and to design them so that they're efficient and clean and safe."

"Sekisui's sponsorship of the SPE PlastiVan, which spent five days educating area 5th - through 12th-graders through hands-on learning activities, is an investment in the future workforce in the plastics industry," said Shannon M. Munro, executive director of Workforce Development & Continuing Education at the college. "Awareness of the plastics industry and what it means to Pennsylvania as one of the largest sectors in manufacturing is critical



to its continued success, and we were pleased to be part of the events on campus and at Bloomsburg and Central Columbia high schools.”

Many of the students involved in the presentation and lab experiments were amazed at the pervasiveness of plastics in their lives, touching virtually every aspect of their day.

“I would love to see a documentary where all of a sudden, all of the plastic was just gone,” Vitale said. “And what would be left? It’s hard to even imagine. We would have wood ... and metal ... and stone.”

Penn College, which has built strong relationships with Sekisui SPI and the Society of Plastics Engineers, was an ideal venue for the traveling resource.

Its School of Industrial, Computing & Engineering Technologies offers two ABET-accredited majors: a bachelor’s degree in plastics and polymer engineering technology and an associate degree in plastics and polymer technology.

In addition, the school is home to the Plastics Innovation & Resource Center, one of the nation’s top facilities for research, development and education related to injection molding, extrusion, blow molding, rotational molding and thermoforming.

For more about the college, a national leader in applied technology education and workforce development, visit www.pct.edu, email admissions@pct.edu or call toll-free 800-367-9222. |



Did you know
the SPE Foundation offers numerous scholarships to students who have demonstrated or expressed an interest in the plastics industry? www.4spe.org/Foundation

North American Plastics Industry Survey 2016 Report

Editor's Note: We are grateful to Jeff Mengel at Plante Moran for granting us permission to reprint excerpts of their North American Plastics Industry Survey 2016 Report. The full report can be downloaded from www.plantemoran.com. Later this year, we will offer our readers an executive summary of P-M's newest report.

Despite Rampant Uncertainty Elsewhere, the Plastics Industry Remains Strong

It's an election year. Global oil supply is imbalanced. Geo-political issues around the world continue to force government intervention and drive fear in many. Analysts continue to hang on every word uttered by the Fed, looking for clarity into the health of the U.S. economy.

As the above issues continue to dominate the headlines, we acknowledge that some of these issues could create headwinds for plastics processors in the future. In the meantime, we are pleased to report that the North American plastics processor industry appears to be staying focused on operating efficiently and continues to offer growth opportunities for many (not all) processors. This is driven by several key factors including:

- A 10-year high in productivity. More specifically, labor productivity. Plastics processors continue to carefully manage their labor costs. This is usually a processor's second-highest expense (next to material), and it is an expense for which the average processor has more control as compared to material costs.
- Solid growth in transportation, building & construction,

and consumer products markets fueled by favorable economic conditions including low employment and fuel prices, ample access to credit, and a strong housing market.

- Mexico continues to drive opportunities for plastics processors serving several end markets (we expand on this point in the feature section on pages 10 through 13.)
- Resin prices for high-volume resins such as high-density polyethylene (HDPE) and polypropylene (PP) went from long periods of reasonable stability to noteworthy declines heading into 2016.

How long can it last?

We're often asked, "how long this industry will remain as healthy as it has been over the past few years?" While we don't have a crystal ball, we don't see any metrics in our data that point to an imminent downturn. However, plastics processor serve cyclical industries that some could argue are due for compression and would be negatively impacted by the "headline issues" we mentioned above. Our recommendation is to understand your company's market position and to focus on your strengths to drive profitable growth. Being focused on the top and bottom line can provide your best insulation from known and unknown challenges that lie ahead.

Insights: Higher Productivity and Profits Bolster Overall Industry Health

The following graph shows year-over-year adjustments to productivity as measured by value-add per employee, equipment utilization percentage, and gross profit margins for the last 10 years.

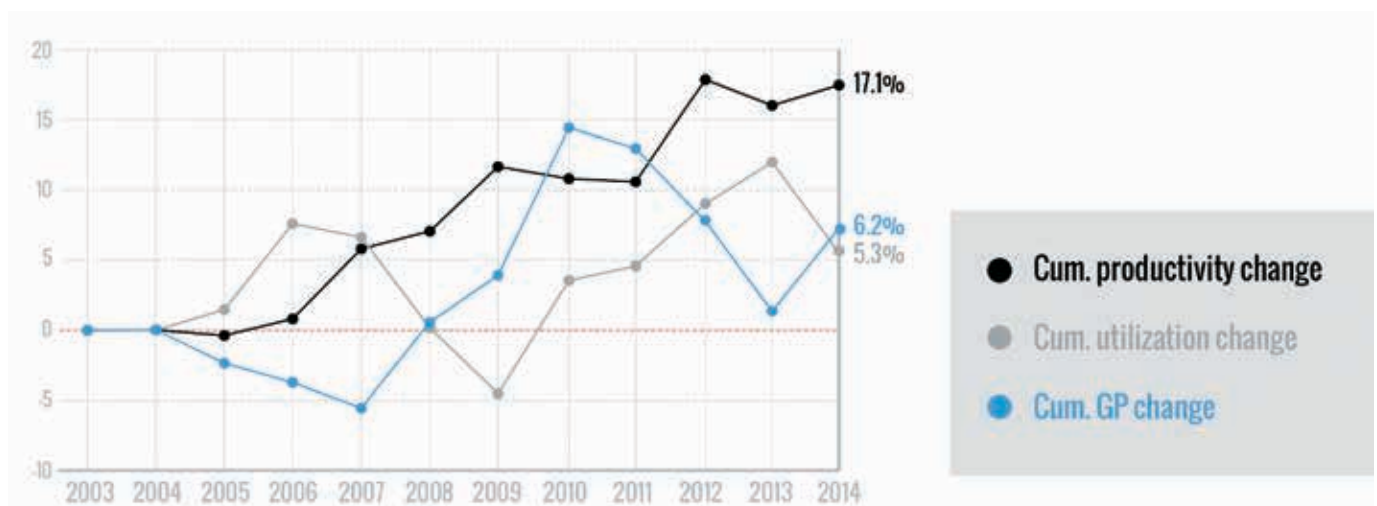

Select 2015 benchmarking analytics

For comparison purposes, we aligned the (average) of the statement of operations and the (median) of select benchmarking analytics versus the successful company performance.

MEAN DATA BY SALES QUARTILE					
2013/2015 DATA	<\$11.9M	>\$11.9M & <\$19.6 M	>\$19.6M & < \$42.3M	>\$42.3M	SUCCESSFUL COMPANY ¹
SALES					
Production Sales	93.6%	98.5%	96.6%	97.8%	96.6%
Tooling Sales	13.4%	6.9%	7.9%	4.0%	8.5%
Less: Tooling COGS	(7.8%)	(5.5%)	(5.4%)	(2.9%)	(6.0%)
Other Operating Revenue	0.8%	0.1%	0.9%	1.1%	0.9%
Total Sales	100.0%	100.0%	100.0%	100.0%	100.0%
COST OF SALES					
Raw Materials	28.7%	37.0%	35.7%	36.7%	34.0%
Purchased Components	6.1%	4.8%	7.5%	9.4%	5.6%
Other Direct Costs	2.6%	2.8%	2.4%	3.1%	2.6%
Direct Labor	13.0%	10.7%	9.4%	8.9%	9.2%
Overhead Costs	28.2%	25.1%	25.0%	24.1%	23.3%
Total Cost of Goods Sold	78.6%	80.4%	80.0%	82.2%	74.7%
Gross Profit	21.4%	19.6%	20.0%	17.8%	25.3%
Selling, General, and Administrative Costs	16.0%	12.7%	12.4%	8.7%	12.1%
Operating Income	5.4%	7.0%	7.6%	9.0%	13.2%
SELECT BENCHMARKING ANALYTICS					
Value Add Per Labor Dollar ²	\$2.15	\$2.15	\$2.26	\$2.65	\$2.31
Complexity - Probable - Injection ³	244,900	387,972	1,736,640	1,289,376	2,243,708
Press Utilization - Injection	27%	37%	47%	50%	42%
Two Year Sales Growth	2%	7%	8%	11%	12%

1. A Successful Company exceeds 10% return on sales (before interest, taxes, and owners compensation), return on assets of 15%, and sales growth of greater than 5%
2. Value add per Labor Dollar = (Sales — Purchased Materials)/Total Labor
3. Complexity equals frequently used resins x (active molds + inserts) x presses

The Business of Thermoforming

● Cum. productivity change



Productivity

At a 10-year high, up 17.1 percent from 2004. The majority of processors who survived the great recession improved their labor cost structure every

year since then, resulting in higher profits and a more competitive outlook. The trend for processors to be highly in tuned with their labor costs is expected to continue as the rewards for doing so can be quite impactful.

● Cum. utilization change



Utilization

Press utilization decreased for the second consecutive year. There has been significant investment in new equipment since 2008 that is now showing declines

in utilization. Is this a harbinger of future gross profit compression? Time will tell.

● Cum. GP change



Profits

Gross profit margins have increased to pre-2009 recession levels after falling for the past four years. Total sales were slightly lower, but resulted in similar earnings. The

industry needs to be careful to maintain pricing disciplines with its customers as margins continue to be tight.

A second look at successful companies

So what drives profitable growth? For the second consecutive year, to answer this question, we reviewed some of the key metrics for which Successful Companies* have outstanding results. We also analyzed key

business processes which these companies consistently embrace.

Effective labor management

- Value add per labor dollar
- Turnover
- Automation

Commercial discipline

Only 6% of sales of Successful Companies have gross margins of 10% or less compared to the industry average of 18%.

Take care of your balance sheet

- ROA
- RONCE
- Altman Z Score



A strong balance sheet drives positive returns and the ability to grow.

Innovation

Successful Companies can be innovative by developing product solutions to meet rising customer demands as well as by managing operations more efficiently than competitors.

Efficient program launches

Successful Companies know that launches can become money pits if not properly managed with formal processes and effective teams.

Managing operational complexity**

Successful Companies have operating processes and procedures that are highly aligned with their complexity.

- Successful Companies with high complexity are skilled at inventory and supply chain management, plant layout design, and customer service.
- Successful Companies with low complexity are highly skilled at labor efficiency and asset utilization.

As we conclude our analysis, take time to reflect on the following questions:

- What are the key drivers of profitable growth at your company?
- What are your profit pitfalls?
- Are you positioned to sustain profitable growth? |

*The term Successful Company for purposes of this study refers to any company that exceeds a 10% return on sales (before interest and taxes – adjusted for owner compensation), return on assets in excess of 15%, and sales growth greater than 5%.

**Complexity equals number of resins x number of molds x numbers of presses



Thermoforming Packaging Technology Molds



IML-T *Setting standards!*



RV 74 *TF made easy!*



RDM 75K *Simply the best!*



Complete turnkey solutions with superior performance!

ILLIG Maschinenbau GmbH & Co KG
Headquarters, Germany
www.illig.de

ILLIG USA
In North America call toll-free
1-855-824 00 04, mail@illigusa.com

Closing the Skills Gap: Creating Workforce-Development Programs that Work for Everyone

By Martha Laboissiere and Mona Mourshed,
McKinsey & Company

Editor's Note: TQ is pleased to offer our readers this reprint from McKinsey & Company's Social Sector Practice. Our members will know that the Thermoforming Division has identified workforce development as a strategic imperative for our industry. We continue to focus on this subject with data and reporting from a variety of sources.

The “skills gap” in the United States is serious. Here is how to do better.

“The land of opportunity”—that is the promise of the United States. And one of the reasons the country has been able to deliver on that promise is that it has been able to develop the talent it needs to create wealth and to adapt to ever-changing economic realities. But there are concerns that the United States can and should be doing better. This will require policies and actions on many fronts, for example on trade, taxation, regulation, education, and fiscal and monetary policy. In this article, we focus on a single subject: preparing people without college degrees for jobs with promising career paths. The need, for both business and society, is clear.

On the one hand, almost 40 percent of American employers say they cannot find people with the skills they need, even for entry-level jobs. Almost 60 percent complain of lack of preparation, even for entry-level jobs. On the other hand, this “skills gap” represents a massive pool of untapped talent, and it has dire consequences, including economic underperformance, social unrest, and individual despair.

The skills gap takes different forms. In some cases, it is a matter of youth struggling to enter the workforce; in others, it is midcareer learners who have lost their jobs because of factory closings or layoffs, and who now must adapt. Whatever the circumstance, when people are disconnected from the workplace, they often disconnect from other social institutions as well. This is not healthy—neither for those left out nor for the societies in which they live.

Recognizing the importance of this subject, McKinsey

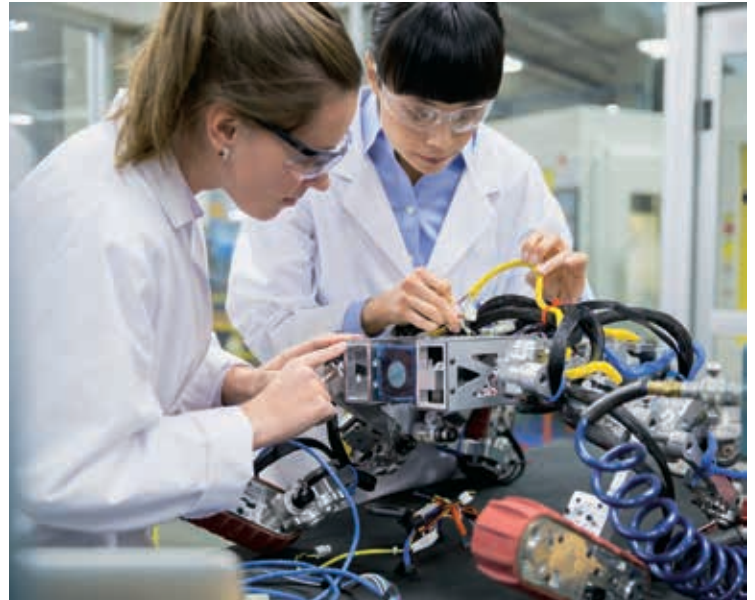

& Company has done extensive research on global workforce-development programs and economic strategies.¹ We have also worked with a number of state, local, and national governments.

So based on our research and experience, we have identified five principles that we believe should be the foundation of workforce-development programs—for funders, participants, and employers (Exhibit 1).

1. Define geographic assets and identify target professions. To get where they want to go, state and local agencies need to know where they are starting. Even at the local level, economies are complicated.

The most promising approach, then, is to identify sectors with high growth potential where there are shortages or a high turnover of workers. Governments should conduct job-market analyses to identify each area’s distinctive attributes and supply-and-demand dynamics, as well as the current state of the workforce. This means looking at posted job vacancies, public infrastructure investment, demographics, local university-research commercialization, venture-capital spending, and regulation. The analysis should be done at the city and regional levels, and then buttressed by interviews with major companies in the area.

We have found the best workforce-development solutions happen when leading employers come together to address

Exhibit 1 The US workforce-development system involves numerous stakeholders.

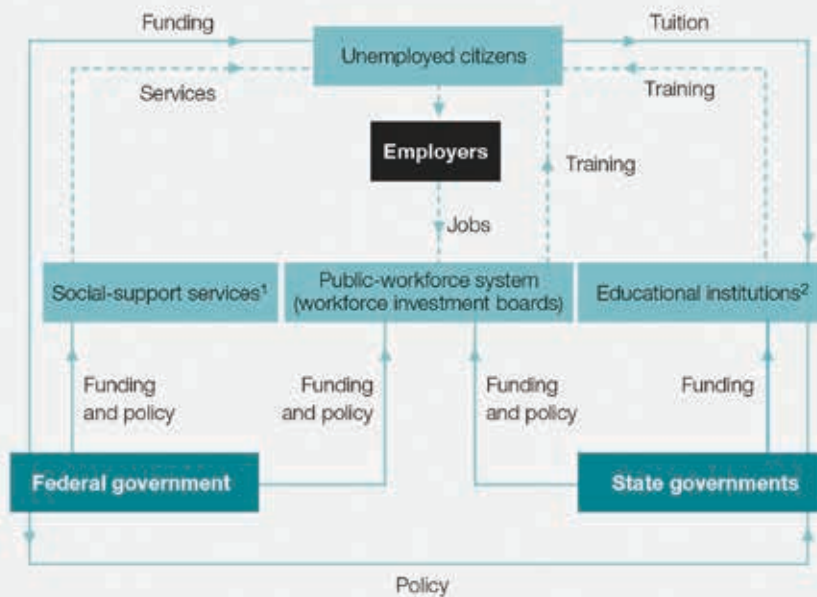

¹Such as child care and transportation.
²Including universities.

the talent problem for an entire sector. Assuming there are no antitrust issues, such collaborations can be attractive to industry competitors because the training costs are shared and the risk of poaching is limited. Such efforts typically take three forms: down a supply chain, with an anchor company taking the lead in encouraging its suppliers to participate; by a functional profession (for example, mechatronics) that is in demand by employers in different industries in the same location; and by sector, with competitors collaborating because they all face the same talent problem. One example of the latter is the Automotive Manufacturing Technical Education Collaborative, which includes 19 automotive companies and 26 community colleges in 13 states.

In addition, government must ask itself whether it has the capabilities to meet the needs of businesses. This can be done simply—ask. Then, based on the responses, work with industry leaders, education providers, government agencies, and trade associations to identify the highest priorities on which to focus.

Successful economic-development efforts develop long-term strategies and make investment decisions based on

hard data. A clear-eyed view allows decisions to be made based on a region’s actual strengths, and avoids chasing economic development fads where there is no basis for competitive advantage. The advice is ancient, but pertinent: know thyself.

2. Deliver ROI to employers and workers.

Hard evidence of return on investment (ROI) for workforce-development programs is scarce, for both employers and workers. That lack of proof is why many employers are reluctant to participate in workforce programs, much less to pay for them. Therefore, metrics that link such programs to business

performance should be tracked, including the cost of program recruitment and training, employer productivity and quality outcomes, retention, and speed to promotion.

Recent federal legislation, known as the Workforce Innovation and Opportunity Act (WIOA), aims to make the workforce-development system more outcome driven and to emphasize training that leads to jobs. Gathering employer ROI data is not only important for employers but can also help local agencies meet WIOA requirements.

If the ROI case can be proved, our research and experience shows that employers are willing to pay for training programs— up to 15 percent (or roughly two months) of the employee’s annual salary, on average. In areas of extreme scarcity, they will do much more. Apprenticeship 2000, a consortium based in Charlotte, North Carolina, comprises eight manufacturers that collaborate with the local community college on a mechatronics apprenticeship. It costs members \$175,000 per candidate over four years.

With respect to participants, few employment programs gather evidence of effectiveness. Some track job

placement at completion, or retention after one to three months. Few programs, however, follow a range of metrics to show potential participants that their investment in time and effort will pay off with personal and financial wellbeing. No wonder many job-training candidates are wary. Successful programs, in contrast, can show candidates evidence that the program will place them in jobs with a future after finishing the course.

Once on the job, metrics to track include the income of program graduates before and after completion, continued employment, job promotion, and reliance on public support. These findings can help reveal what works—and just as important—what doesn't. Programs that fall short can then be cut in favor of those that succeed.

3. Support comprehensive, demand-driven training methods.

Local, state, and federal agencies have made numerous efforts to work with businesses, regional groups, education providers, and other stakeholders to deliver effective job training. Some training programs are excellent—others, not so much. Evidence does exist, however, of models that work in a variety of industry and regional contexts (Exhibit 2).

In successful programs, employers are involved from the start and guarantee interviews for graduates. Once providers decide which sectors and which high-scarcity or high-turnover professions to pursue, the next step is to shadow employees on the job in those professions. The goal is to identify which activities most differentiate high from low performers and to translate this insight into training for the right technical, behavioral, and mind-set skills which include attributes such as punctuality, diligence, and follow-through). Such observation is important, because our experience is that many employers are unable

Exhibit 2 Effective training incorporates five components.

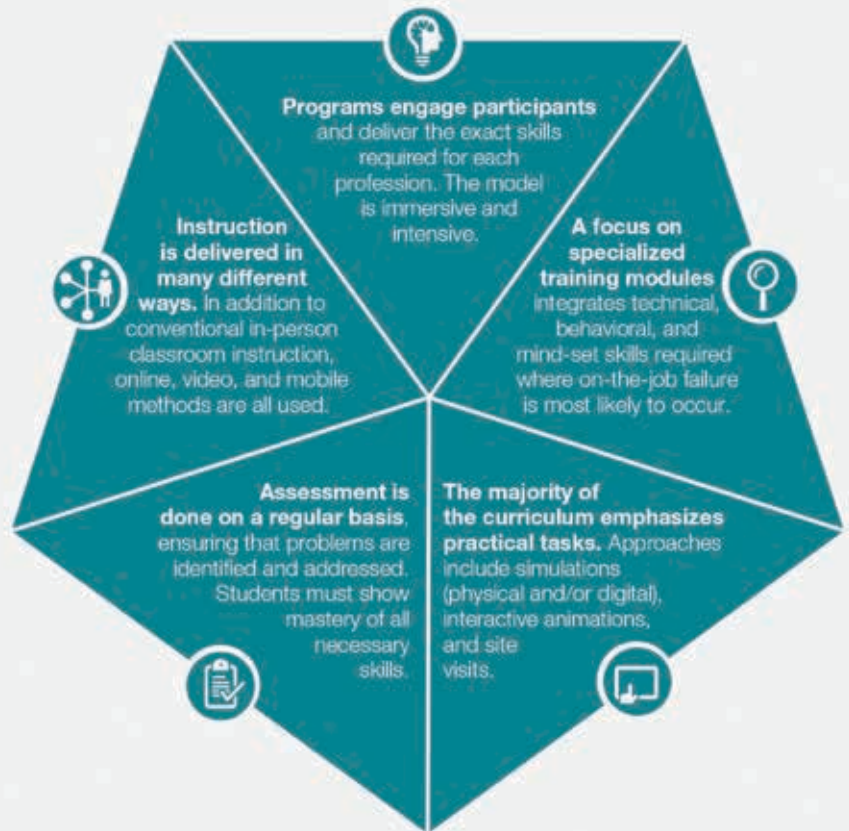

to accurately describe which skills matter most, leading to errors in program design.

In delivering training, one proven approach is to provide two- to three-month "boot camps." During the boot camp, competency is assessed regularly, based on actual demonstrations. Employers collaborate with the training providers and can offer their staff as trainers. The boot camp must be practical, including in-person simulations, on-site apprenticeships, and "serious games" customized to the workplace, where learners can play virtually and repeatedly. Programs need to have a strong in-person component to deliver the necessary dosage of intensive practice and to build the trust that allows providers to support learners—many of whom face multiple life challenges. At the same time, technology-based solutions, such as online applications, mobile apps that track learner performance, and digital workplace simulations can significantly increase the efficiency and effectiveness of these in-person programs.



ADVANCED EXTRUDER TECHNOLOGIES

Design | Engineering | Manufacturing



CUSTOM, SHEET EXTRUSION SYSTEM DRYER-LESS, PET / PLA SHEET EXTRUSION SYSTEM



- High Performance
- Low Melt Temperature
- Short Dwell Time
- Excellent Mixing
- Low Energy Consumption
- High Vacuum System
- In-line IV Monitoring/Control System
- Compact Design
- Robust Design
- FDA Approved

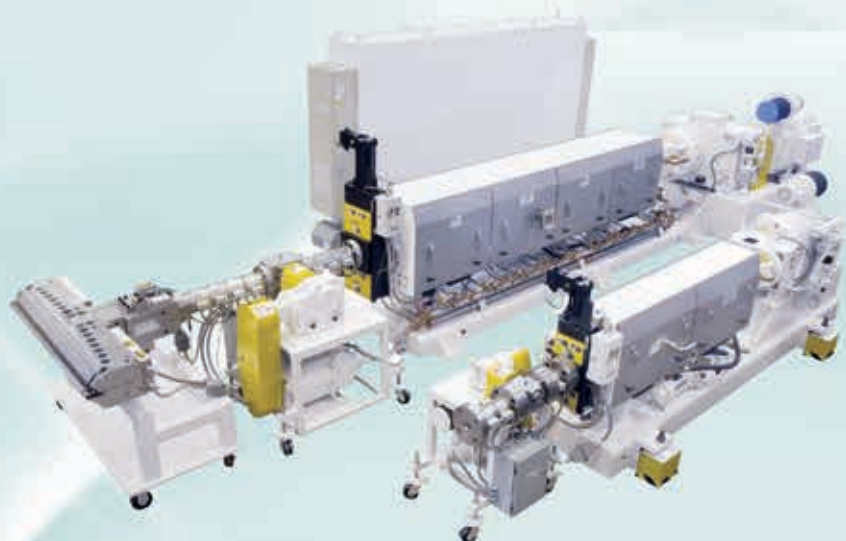

- Mono Layer- Barrier Co Extrusion
- Thin Gauge – Heavy Gauge
- Extruder Size: 1.5”- 15” In Screw Dia.
- Quick Roll Change Design
- Custom Configuration
- Servo Driven
- Independently Driven
- Roll Diameter: 12”- 40”
- Face Width: 36”- 150”
- State-of-the-Art HMI Control System
- Unparallel Customer Service & Support
- Technology Driven



ADVANCED EXTRUDER TECHNOLOGIES, INC.

Commitment to Excellence

To reach the people who need these programs most—meaning those at risk of being disconnected from the workforce because of background or education—accessibility is critical. Meeting their needs for transportation or child care during the boot camp, for example, helps make it possible for them to succeed. Programs that respond to these needs see higher completion rates. Some go even further, providing postgraduate mentorship for the first few months on the job, which is the period of greatest vulnerability. If individuals can make it through the first three months on the job, the odds of them continuing to thrive professionally and personally rise significantly.

4. Assess and prepare learners before they start training. Programs need to start by ensuring that learners are ready to train for the professions to which they apply. For example, they must be able to meet job-licensing requirements, such as having a high-school diploma, or pass a background check or a drug test; they also need to show jobappropriate literacy and numeracy levels.

Once this basic screening is done, there are ways to improve retention in the program and in the job. One is simple: make sure that people know what the job is before they start the training. This explanation must cover both positive and negative aspects, and might include things such as showing videos, hosting discussions of a “day in the life” with workers, and spending time at the job site. Someone training to be a certified nursing assistant, for example, needs to know that the position can be physically demanding and requires shift work.

When people understand what it takes to succeed at a given job, they are more likely to choose one that is right for them. That, in turn, improves program completion, job placement, and retention. It also ensures that program resources are spent on those who are most likely to benefit.

5. Coordinate the workforce-development process centrally. Estimated spending on US workforce-development programs for those not going to four-year colleges—everything from federal and state jobs programs, workforce training and certifications, community college, and employer training—is at least \$300 billion a year.² Most programs, however, are deployed in isolation and are not integrated with other services deployed by other entities. For example, a common scenario is that responsibility lies in different places: job training lies with

the state’s workforce department, child care and food assistance lies with the social services, and mentorship support lies with a local philanthropy or not for profit. All these components are essential to the learner’s success in completing the training, finding a job, and then succeeding at it. Such tight complementarity of service delivery to learners, however, rarely occurs.

State governments can deploy three strategies to ensure effective use of resources. First, have a clear view of all funding and efforts available for target learner segments and professions in a given location, and coordinate these to deliver holistic services to learners. Second, establish a set of outcomes and performance-management processes in which learner employment within 30 days of program completion, retention on the job, and income increases lie at the heart. Finally, ensure the provision of human, technology, and data-analytics capacity for program delivery that supports learners.

State and local public agencies want to help their citizens succeed. To do so, one priority is to better use the considerable resources that are available, by coordinating the mishmash of funding that now flows through numerous departments and agencies. A second is to improve job outcomes for program participants and employers in the WIOA context. A third is to do so on a large scale and at reasonable cost. There are proven ways to do this that benefit individual workers, companies, and the economy as a whole. By investing in talent in this way, governments and businesses will also be reinvesting in the American dream.

References

1. Dominic Barton, Diana Farrell, and Mona Mourshed, “Education to employment: Designing a system that works,” McKinsey & Company, January 2013, McKinsey.com.
2. Anthony P. Carnevale, Artem Gulish, and Jeff Strohl, College is just the beginning: Employers’ role in the \$1.1 trillion postsecondary education and training system, Georgetown University Center on Education and the Workforce, 2015, <https://cew.georgetown.edu/wp-content/uploads/2015/02/Trillion-Dollar-Training-System-.pdf>.

This article was originally published by McKinsey & Company, www.mckinsey.com. Copyright © 2017 All rights reserved. Reprinted by permission. |



LOW FLEX™ FORMER SERIES

- *LF5.0 Shown – 190 Ton*
- *Numerous quick change features*
- *Easy maintenance access*

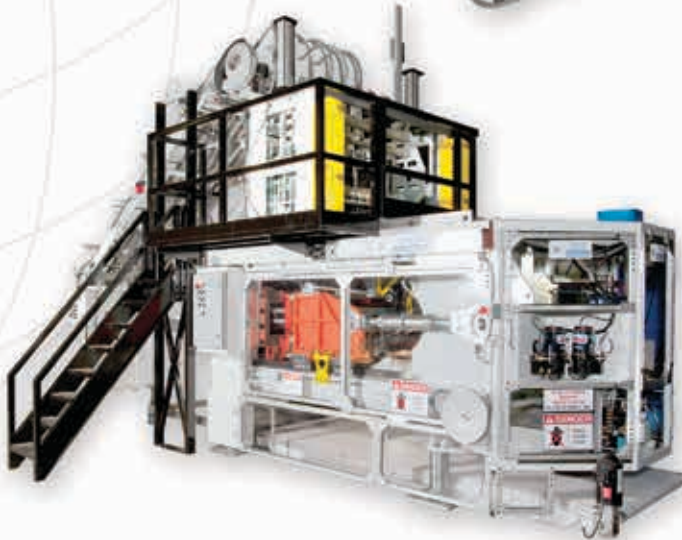

LINEAR RAIL TRIM PRESS

- *LR5 Shown - 45 Ton*
- *Side Loading of Tool*
- *Numerous quick change features*
- *Precise tolerances via linear rails*

TECHNOLOGY

*Flat Bed Formers
Form-Trim Models
Linear Trim Presses
Linear Vertical Press
Heavy Duty Presses
Tilt Bed (IML)
Linear Pre-Punch
Linear Scoring Station
Rotary Drum Former*

PROCESSES

*- PP, PET, HIPS, OPS
- PLA, HDPE, PS Foam
- In line/Roll Fed
- Cups, Car Cups, Lids
- Retort Products
- Tamper Evident
- Hinged Trays
- Storage containers
- TIML*

VALUE

*- Energy Efficient
- Production Rates
- Move Times
- Ease of Access
- Reliability*

SERVICE

*- Training Classes
- On line help
- Process Training
- After hours help
- Included start up service*



Thermoforming Systems LLC

1601 W. Pine Street, Union Gap, WA 98903-9502 • 509 454 4578 • Fax 509 454 4598

www.tslusa.biz

Thermoforming Technical Problems I Wish I Could Solve Heating the Sagging Sheet

By Jim Throne, Dunedin, FL

Prologue

Sheet sags while being heated. Nearly all sheet is heated radiantly and nearly all of that sheet is heated from both sides. We spent inordinate hours balancing our heaters to ensure nearly the same energy input to each side of the sheet. Great technical minds propose mind-expanding mathematical treatises to describe how the sheet accepts the energy. And everybody envisions the sheet in the oven as a triad of parallel planes: top heater, sheet, bottom heater. But we all know that as the sheet heats, it begins to sag under its own weight. In short, the heated sheet is no longer planar.

And the problem is...?

Radiant energy from any point source moves outward in a hemispherical fashion. An object that is close to the radiant source will receive more incident energy than one that is further away. As the sheet sags, the center moves downward toward the lower heaters and away from the upper heaters. So, we assume, the top center surface, being further away from the top energy source than other spots on the top surface, should heat more slowly. And further, the bottom center surface, being closer to the bottom energy source than other spots on the bottom surface, should heat more quickly. We can show that this way.

the sheet are shortest for the rays that are perpendicular to the heaters. Therefore the sheet at those specific spots sees the greatest amounts of inbound energy. Conversely for spots on the sheet surface where the rays have angles substantially less than perpendicular receive much lower amounts of inbound energy from any specific spot on the heater surface. Most apparent, however, is that each surface of the sheet receives the same amount of inbound energy from each hot spot.

In the next figure, the sheet has begun to sag.

The Effect of Sag on Radiant Energy Distribution

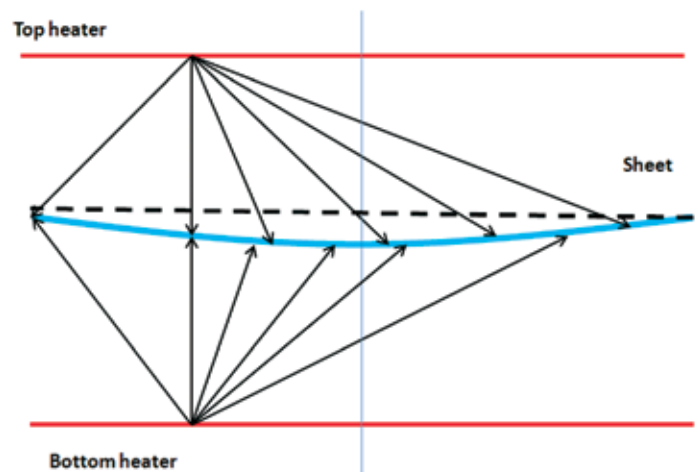

The distances between the hot spot on the top heater and the top of the sheet have increased, whereas the distances between the hot spot on the bottom of the heater and the bottom of the sheet have decreased. As a result, the

The Effect of Sag on Radiant Energy Distribution

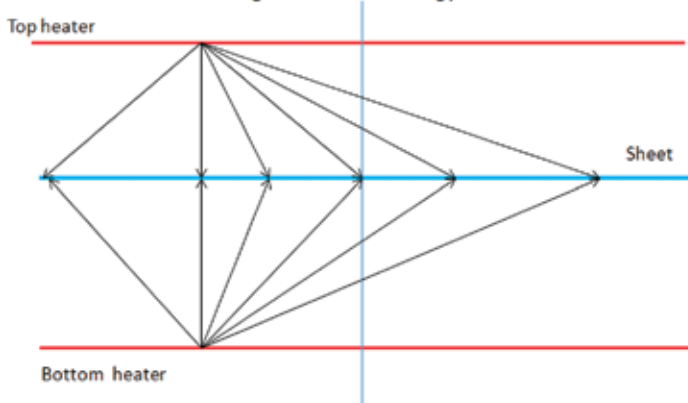

In the first figure, we see that the ray lines from opposite hot spots on the top and bottom heaters touch at the planar sheet. Now the effect of radiation decreases in proportion to the distance squared between the source and the sink. Thus the distances between the heaters and

The Effect of Sag on Radiant Energy Distribution

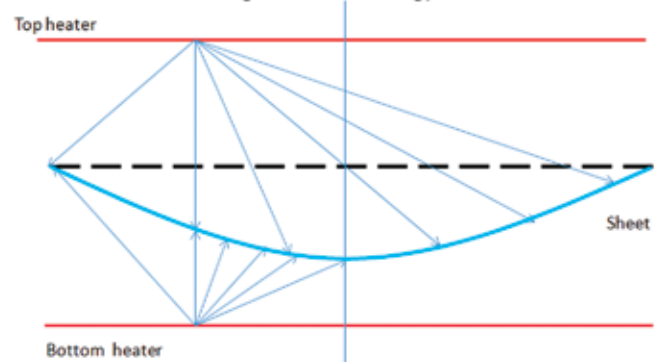

amount of inbound energy from the top hot spot has decreased and that for the bottom hot spot has increased. In short, the heating rate of the top of the sheet has decreased and that of the bottom has increased. As sag continues, the imbalance is exacerbated, as shown in the third illustration.

This imbalance is seen in the extreme below.

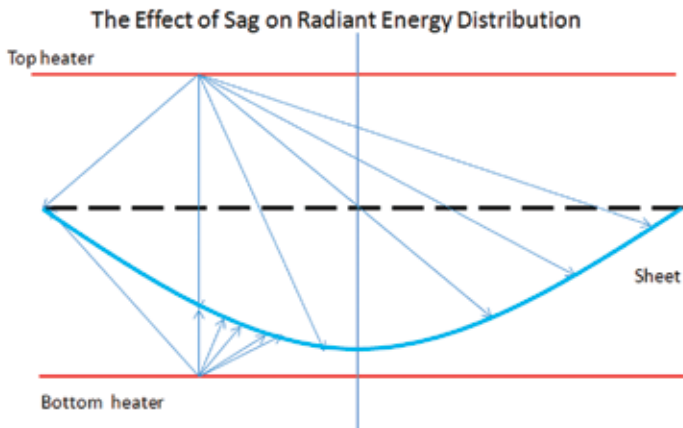

So the top center of the sagging sheet is much colder than elsewhere while the bottom center is much hotter. The consequence is that the formable sheet is non-uniform in its temperature, both through the sheet and across the sheet. Seems pretty straight-forward, right? Maybe not.

HYTAC® Innovative Tooling Materials for Thermoforming

CMT

US: +1 508 226 3901 | www.cmtmaterials.com | EU: +31 416 747 016

Great Plugs = Great Parts

Maybe not?

What about the point energy sources on the edges of the heaters? Do they contribute in any way to this differential heating issue? Consider the last example. The sagging sheet is actually blocking some of the radiant energy from the edges of the bottom heaters. Similarly, the sagging sheet is actually seeing more of the radiant energy from the edges of the top heater.

So why not just solve the problem?

It has been solved in at least one case: two-dimensional catenary sag. The mathematics are awesome. The problem is that this model does not describe the increasing surface area of the sagging sheet.

Furthermore, temperature profiles through the sheet for a time-dependent, three-dimensional sag of a rectangular sheet have not been attempted. Instead, I suggest a set of experiments using a mesh of IR thermometers mounted through the oven wall to monitor many spots on a thick sagging sheet. This would yield a time-dependent mapping of the sheet surface temperatures along with actual measurements of the extent of sag beneath each of these spots. This set of experiments should be carried out for both the top and bottom heaters. Using traditional transient heat transfer models, it should be possible to back out the time-dependent radiant energy contributed by heaters in those spot areas. And this information should help determine how significant sagging is to the overall heating characteristics of the sheet.

Has this been done? Not to my knowledge. Does it seem feasible? Of course. |

Quality Thermoform Molds Since 1972

PCM

Portage Casting & Mold, Inc.
2901 Portage Road, Portage, WI
1-800-356-5337 • www.pcmwi.com

REDUCE REUSE RECYCLE

PROFILE PLASTICS

We Deliver Parts... Under Pressure™

847.604.5100
www.thermoform.com

CUSTOM HEAVY GAUGE THERMOFORMING
PRESSURE • VACUUM • TWIN SHEET • ASSEMBLY

The Production of Drinking Cups, Part 2

Written in cooperation with Paul de Mink, Borealis AG, Austria, and Norbert Hufnagl, Kiefel GmbH, Germany

[Editor's note: the following article is adapted from *Advanced Thermoforming* by Sven Engelmann DiplIng., Director of Packaging Technology at Illig in Heilbronn, Germany. Mr. Engelmann has a distinguished career in polymer science and thermoforming technology. Prior to his return to Illig, Mr. Engelmann was a Director of R&D at EBB Microparts and the Director of Polymer Technology at Gerhard Schubert GmbH, a leading designer and manufacturer of innovative form/fill/seal technologies. In addition to his work in the private sector, he is a lecturer at the University of Stuttgart and the Aalen University of Applied Sciences where he teaches "Basics of Thermoforming." He is the author of numerous articles published in both the US and Europe on thermoforming, polymer processing and injection molding. His recent book, published by Wiley, can be purchased on Amazon. He can be contacted at sven.engelmann@illig.de. This particular chapter was written in conjunction with Mr. Paul de Mink who recently passed away. Mr. Engelmann would like to acknowledge Paul's contributions and recognize his friendship over many years.]

36.7 Influence of Nucleation of PP on Processing and Characteristics of the Finished Part

The thermoformability, and accordingly the properties of a finished part, depend primarily on the morphological structure of the film. These properties are altered by chilling or by the addition of germs (nucleation). After the extruder a chill roll or calendar stack, as a chilling unit, will follow, depending on the thickness of the film.

Next high chilling, for not nucleated PP, obtains a fine-grained structural composition over the cross section of the film, which for nucleated types has no relevance. That means that unlike the unfavorable influence of increasing chilling temperatures, on the crystalline structure of standard PP, the brittleness and optics will be less affected with the nucleated film (Figure 36.15). As a result a higher speed of production (less time at the calendar stack) is possible.

36.7.1 Types of Nucleation

Basically there are two types of heterogenic nucleating agents:

- Inorganic nucleating agent (e.g., talcum, mica, kaolin).
- Organic nucleating agent (e.g., benzoate, sorbitole).

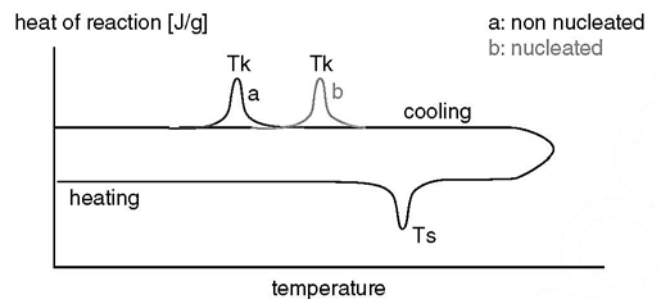

Figure 36.16 Nucleating effect (Courtesy of Borealis AG)

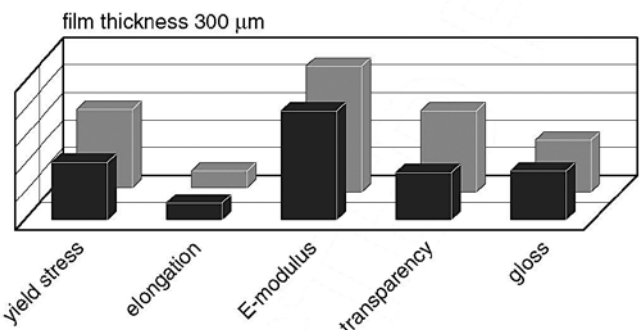

Figure 36.17 Nucleation impact on mechanical and optical properties (Courtesy of Borealis AG)

NUCLEATING EFFECT morphological structure

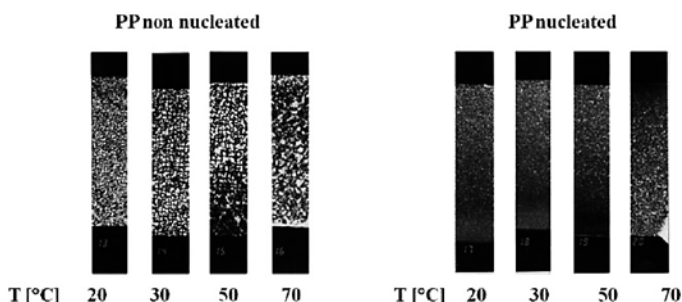

Figure 36.15 Nucleating effect, morphological structure (Courtesy of Borealis AG)

Mode of action of nucleation:

- Changed crystalline behavior (Figure 36.16)
- Higher crystallization due to the higher crystalline temperature.
- Fine spherulite structural conditions (improved optical properties)
- Improved thermoform film properties (mechanical

properties like E-modulus and yield stress, and the optical properties like transparency and gloss; (Figure 36.17).

36.8 High Crystalline/High Stiffness Polypropylene

In comparison to standard PP, the high stiffness PP has a higher isotactical index (>98%) and higher stereoregularity (even order of CH₃ side groups).⁷ Crystallization of the produced film will be higher with this combination and also, from the special nucleating agent, a fine spherulitic structural condition will be achieved. The advantages of such modification are excellent thermoformability (high output, faster forming cycles, easily stacked finish parts), high stiffness, good toughness, and also high temperature durability. So the finished parts have a better water vapor barrier (Figure 36.18).

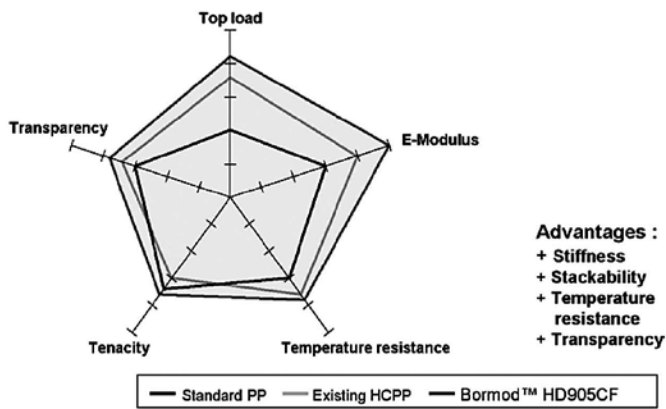

Figure 36.18 High-crystalline and high-stiffness PP (Courtesy of Borealis AG)

The advantages for the thermoformer are, on the one hand, a higher productivity (faster cycles) and, on the other hand, the possibility of a thickness reduction and accordingly a weight reduction, to save material and costs.

36.9 Influence of Film Production Technology

The choice of technology, for the production of thermoforming film, has a major influence on the mechanical, thermal, and optical properties and also the subsequent processing.⁸ Borealis AG has reviewed in a study these properties with regard blister applications on forming, filling, and sealing machines.

A major point in the Borealis study was the substitution of PVC for blister wrapping in the packaging of medications and luxury foods with polypropylene. Using the FSS lines of packaging machine producers, packaging and pharmaceutical companies were asked to approve films

that were produced by water bath technology, and also films that were produced with conventional technology.

Next to the choice of material, the technology used has a big influence on the behavior of the subsequent processing of the produced film. More precisely, in this study the previous history of 300- μ m blister film was at issue. The production technologies that were tested were as follows:

- Chill roll technology (Figure 36.19)
- Calender stack technology (Figure 36.20)
- Water bath technology (Figure 36.21)
- Steel beld technology (Figure 36.22)

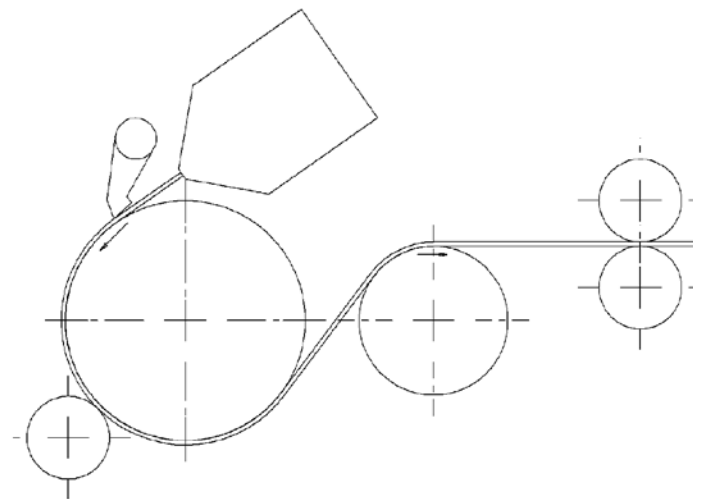

Figure 36.19 (Courtesy of Borealis AG)

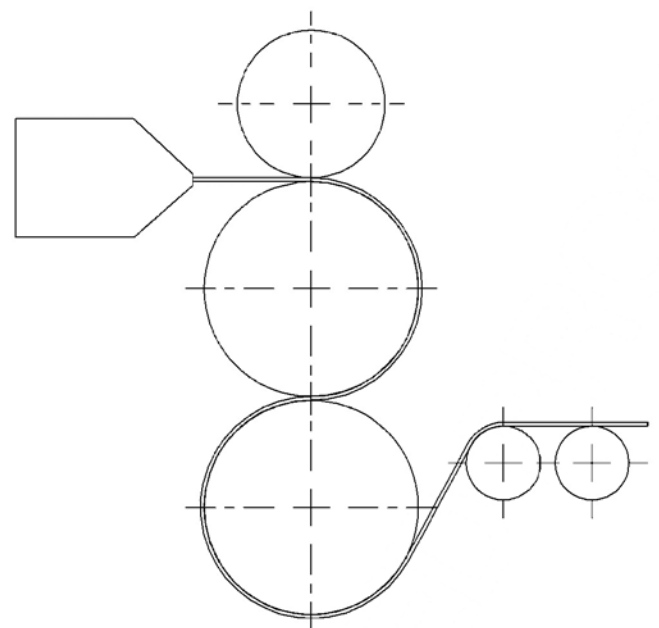

Figure 36.20 (Courtesy of Borealis AG)

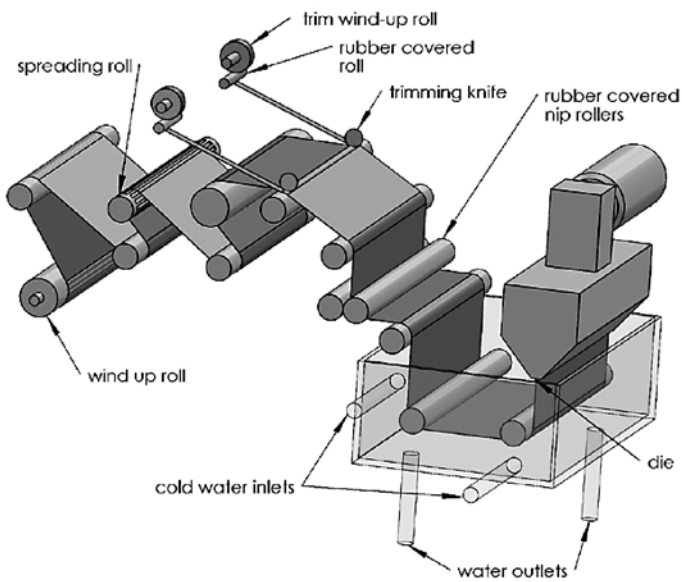

Figure 36.21 (Courtesy of Borealis AG)

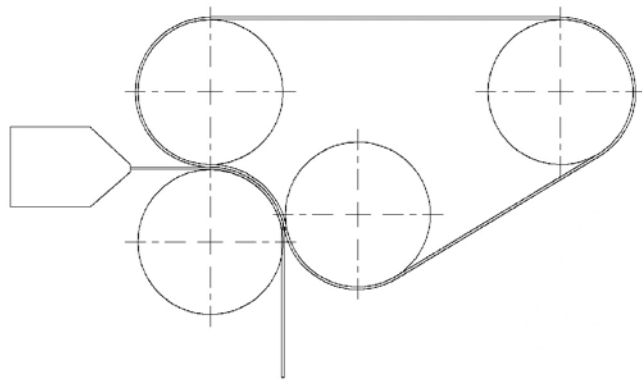

Figure 36.22 (Courtesy of Borealis AG)

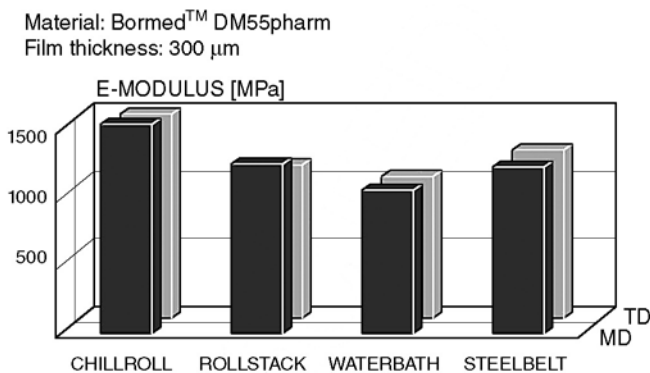

Figure 36.23 Stiffness (Courtesy of Borealis AG)

The material used was Bormed™ DM55pharm (PP-homo; MFR 2.8 g/10 min). Blister films with a thickness of 300 μm were produced. Different technologies and a particular product were used as a base to collect data on specific influences. The analysis and results were discussed and carried out within this group of technologies. This way a direct comparison of the technologies could be made.

Pulling Test

As was expected, the single technologies, based on their different cooling conditions, turned out to have a big influence on crystalline behavior, and with this, also the stiffness of the produced film (Figure 36.23).

Due to the shock of evenly cooling the film by water bath technology, there a relatively small E-modulus with almost identical results in the longitudinal and cross directions. Films that were produced by steel belt technology had also, due to even cooling of the inside and outside, a small difference in the longitudinal and cross directions. The higher E-modulus (~200 μm) of steel belt films compared to water bath films is connected to the lesser cooling capacity (in this case a belt temperature of approximately 50°C). The E-modulus data of calendar stack films are comparable with the data of steel belt films. However, there is a certain anisotropism of the longitudinal and cross directions. This is caused by the orientation in combination with the necessary rolling bank and the corresponding temperatures of the polishing rolls. The highest E-modulus was measured on the chill roll film with the lowest cooling capacity.

This phenomenon is explained by the fact that the use of chill roll technology for the production of 300-μm thick PP film under different cooling conditions of inside (air knife) and outside (chill roll) is critical. For film production the high chill roll temperatures (>80°C) were adjusted to obtain adequate film surface and flatness. The data in the longitudinal and cross directions were fairly consistent, but the high amount of crystallization led to a high E-modulus.

Toughness

The study of toughness showed clearly that water bath technology, due to its very homogeneous and intensive cooling period, prevents the crystallization from becoming too dense and so reaches a higher toughness compared to other production technologies. The energy puncturing the water bath film was about 700% higher than that for the steel belt film.

ANTEC® 2017

The plastics technology conference

May 8-10 - Anaheim, CA



NEW THIS YEAR!
Co-locating with
**Industry 4.0 &
Plasticity**

REGISTER TODAY!
Early bird discounts end March 21st



Keynote Speakers



600+ Technical Talks



Panel Discussions



Speed Interviews



PLASTICS for Life™



New Technology &
Fellows Forums



SPE Awards &
75th Anniversary
Gala



The Plastics Race™



Women's
Networking
Breakfast

Register at: 4spe.org/antec

36.10 Optical Properties

Surface Gloss⁹

Among other things, surface quality is based on the optical characteristic of the film. This means that with better transparency comes better surface gloss. If the four researched cooling technologies are compared for surface gloss, it became clear that the technologies where the cooling period of the melt is done by bilateral contact cooling on polished steel surfaces have the advantage. Even contact cooling between the chilling roll and the cooled steel belt can achieve high surface gloss on both sides. A relatively high gloss on the inside of the film (contact with chill roll 1) can be obtained with the calendar stack technology.

There will be a low gloss on the film outside due to the line-shaped contact (outside) of the polishing stack and the deferred timing when the film meets the second chill roll and through that the consequent advanced crystallization. A second polishing stack between chill roll 1 and chill roll 2 would help even out the gloss (Figure 36.24). However, this is only possible when the cooling temperature is relatively high and a single chill roll drive is available (to prevent wrinkling due to shrinkage). An even gloss on both sides can be achieved when using the water bath technology (homogeneous cooling). With this procedure there is no polishing stack to raise the surface gloss and that is why the gloss data are lower compared to steel belt film. The least favorable way to attain good optical properties of the film in this thickness range (300 μm) appears to be chill roll technology. There will be no particular gloss on both sides of the foil because of the air knife used and the subsequent low the surface pressure on the chill roll.

Haze

The measured data on haze resulting from the different technologies used to produce the films suggest the following. The highest haze data, and therefore least transparency, are found in films produced with chill roll technology. On the one hand, this is due to the low surface gloss and, on the other hand, to the formation of a coarse spheroidal structure from the high cooling temperatures used to produce the film. The best transparency (least haze) was obtained using the water bath technology.

Main reason for this is the even, bilateral chilling of the film, which shocks and inhibits the formation of spherulites, so the amorphous character of the smelter more or less remains. The somewhat higher haze data measured at steel belt film is followed by the calendar stack films (Figure 36.25). Compared to the water bath film there is higher crystallization, and the good transparency has a positive effect on the surface gloss.

Material: Bormed™ DM55pharm
Film thickness: 300 μm

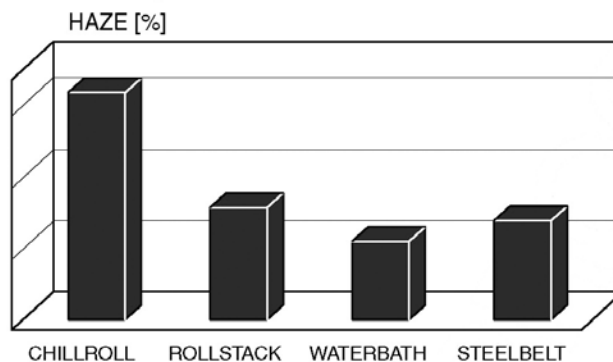

Figure 36.25 Haze (Courtesy of Borealis AG)

36.11 Film Morphology

Microscopical Examination¹⁰

Based on a structural cross-sectional analysis of all films (water bath, steel belt, and calendar stack) there are definite differences in the morphology, and these differences are supported and explained by the results of previous research so far (Figure 36.26).

Clearly, the best and finest structural condition is reached by water bath technology (Figure 36.26). It is noticeable that the outer layers have a certain "starting crystallization" that is a result of belated temperature activity. It turns out therefore that water bath films have, in the mid cross section, a finer structure than in the outer layers. Compared

Material: Bormed™ DM55pharm
Film thickness: 300 μm

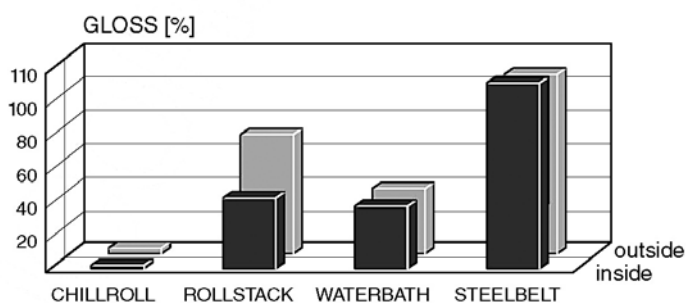

Figure 36.24 Optical properties: gloss (Courtesy of Borealis AG)

Unparalleled Performance in Thermoforming Technology

Combine

a *Quad Series* thermoformer with an *Elite Series* trim press and you have the perfect combination of unparalleled performance in speed, consistency and efficiency.



Quad Series thermoformers are the pinnacle of technology and performance for more precise and consistent parts. Equipped with premium features, *Quad Series* formers are capable of 260 tons holding force and 180 tons coining force with virtually zero deflection across the entire mold area.

*Quad Series*TM & *Elite Series*



Elite Series Servo Driven Horizontal Trim Presses are equipped with a multitude of innovative cutting edge features for achieving greater speeds, superior precision trimming, longer tool life, ease of maintenance and faster changeover times. The *Elite Series* is capable of high speeds in excess of 175 strokes per minute and fast changeover times of less than 30 minutes.



Think Fast. Think Brown.

Global Leader in Thermoforming Solutions

www.brown-machine.com or call 989.435.7741

The Perfect Combination to Maximize Profits

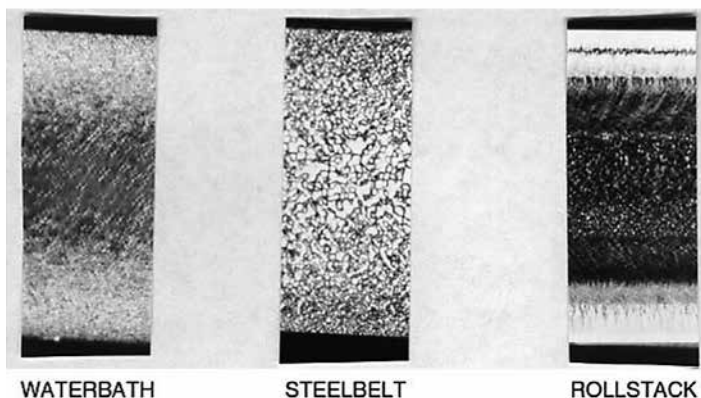

Figure 36.26 Morphological structure (Courtesy of Borealis AG)

to other technologies this is unique, and the homogeneous temperature over the cross section is an enormous advantage for thermoforming.

In comparison the structure of the steel belt film reveals fine-grained edges that grow toward the middle of the film. The high temperature cannot be reduced fast enough during the cooling down of the film. As a result the crystallization in the middle of the film's cross section is higher. This effect is for the subsequent thermoforming rather disadvantageous. To reach a certain molecule chain movement at the center of the film while it is being heating, enough energy must be supplied (PP has a low thermal conductivity). Compared to water bath film there are slightly less beneficial conditions for processing on FFS lines.

The morphology of the polished films is where the differences are extreme. As with the steel belt technology the growth of crystallization toward the middle of the film can be observed. The growth correlates with the film thickness, and there is a certain formation of layer structures. In the production of polished films it may be that a good thickness distribution and a high surface gloss is reached between the calendar stack and the first chill roll worked with a rolling bank. The thinner the chosen thickness of the film, the higher must be the line pressures between the calendar stack and the chill roll. In addition the mass of the rolling bank correlates with the film thickness. This means that the relation of the rolling bank to the appointed polishing gap is about 400 μm high and the deformation mechanism causes differing moving speeds of the circulating melt in the rolling bank. At the

center of the rolling bank the moving speed is next to zero. The material layers located next to the roll surface come close to their speed, based on their adhesion to the cylinder wall. This is why there are formations of different layer structures in the cross section when the film is chilled down.

Mechanical-Thermal Behavior¹¹

Recall that the thermoforming of PP takes place in the transitional state from thermoelastic to thermoplastic, which is when maximum movability of the molecules occurs. It is possible, with the help of a modulus of shear/temperature diagram (torision pendulum test), to draw conclusions as to the behavior and subsequent processing of the thermoforming film (Figure 36.27).

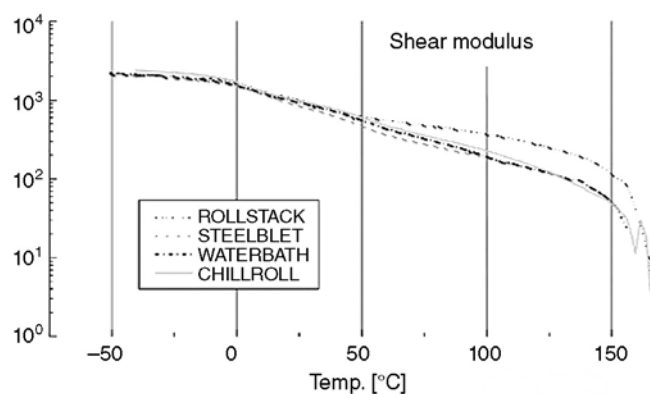

Figure 36.27 Mechanical-thermal behavior (Courtesy of Borealis AG)

In the chart the shear modulus in the temperature range between 100°C and 150°C are compared for the water bath film, steel belt film, and chill roll film. Considerably higher modulus of shear data is attained in polished film with the rollstack method. This means that the movability of macromolecules in the polished film is within this temperature range, compared to films that are produced with different technologies. This suggest that an application of higher energy is needed to reach acceptable thermoforming.

From these results films that are produced with the water bath technology seem to be most advantageous for subsequent processing with FSS equipment. The low crystallization of the produced foil is due to a low deformation temperature that leads to a relatively low E-modulus but with high damping (optimal movability of the molecules).

Innovation. New Products. Research & Development.

To continue to live up to expectations and beyond, Premier Material Concepts has installed a 36" wide, multilayer lab line at its facility in Findlay, OH.

Want to experience the PMC difference firsthand?
Contact your account executive to schedule your visit.

YOUR GO-TO-GUYS

877.289.7626 // sales@buypmc.com // buypmc.com

PMC
PREMIER MATERIAL CONCEPTS

36.12 The Thermoforming Machine

For the production of drinking cups made of polypropylene an automatic thermoforming machine of the KTR series manufactured by the company Kiefel was used. These KTR machines are detailed explained in the chapter 25 "Productive of flower pots". If only a few format changes are demanded then the connection of an extrusion line to the thermoforming machine is advisable. For the processing of PP the heating section in the thermoforming machine must be extended, unlike the processing of other kinds of plastics. This is achieved by a preheating station or by a integrated preheating into the thermoforming machine. Such an integrated preheating has upper and lower heating devices—the same as the main heating. It is important for this application that the thermoforming machine be equipped with a spreadable film transport system in order to compensate the extreme sagging of the heated polypropylene film. An option is to integrate a film transport system with longitudinal expansion. The transport system should nevertheless be expended to prevent the sagging of the heated film so that a plane and tightened film is fed to the thermoforming station. In this way the same conditions can be ensured anywhere in the multi-cavity tooling. This is an essential pre-condition in order to achieve reproducibility of quality within the array of the mold surface. To increase the cycle speed, the use of servomotor-driven actuators in the forming station is also necessary for this application; the plug assist is driven by a servomotor.

For the manufacturing of thermoformed parts—for example, drinking cups made of PP—homogeneous heating of the film is indispensable. The processing temperature must be kept constant and uniformly distributed anywhere over the mold surface. Quick

prestretching of the film is absolutely necessary and achieved by quick and precise servodrives. A precise definition of the formed parts can be achieved if the individual cavities of the mold are filled with forming air very quickly.

It is difficult to heat the polypropylene film, and it is also difficult to draw the heat from the formed part consisting of polypropylene. Therefore the use of an efficient cooling system is necessary.

36.13 The Mold

For some applications it may happen that the forming tool consists of 50 cavities, whereas the respective drinking cup has a punching diameter of 70.3 mm. From a film that has an original thickness of approximately 1 mm, cups with a weight of 2.3 g are thermoformed. The output is 40 cycles/minute. For such speeds the use of directly cooled tools is necessary.

36.14 Stacking

The stacking of 50 formed parts for a cycle speed of 40 products per minute makes the use of high-performance stacking devices necessary, such as the stacking devices of the KIST type manufactured by Kiefel or pickup stacker devices. The unloading of the formed parts from the tools is done with an unloading mandrel. Subsequently a predefined number of cups is stacked to form a pile.

36.15 Downstream Devices

A lot of drinking cups are produced with a so-called U-rim in the molding tool. Drinking cups with the U-rim are beaded by a rim rolling device. The rim rolling device curls the U-rim and thus a round lip at the rim of the cup is created. Normally a rim rolling device consists of three heated screws with axes of symmetry that are parallel with each other. In order to transport the cups through the machine in the center of the rim rolling device the screws are placed in a similar way as in a planetary drive. The screws have tapered threads; thus the U-rims of the cups are deformed as the cups are moved through the device.

Some cups are printed. Subsequently the cups get at the flowrapper where stacks of cups are packaged. In the next step the cup stacks are packed into boxes, upright or lying flat, and then palletized.

**Are You
Linked in?**

Group Name: Thermoforming Division,
a subgroup of SPE. Moderator: Jim Arnet.
With over 1500 members and growing, meet
fellow professionals, ask tough technical
questions, explore related groups.

References

7. Paul de Mink, "PP in der Thermoformung," Pages 47ff, *Extrudieren und Thermoformen von Verpackungsfolien*, VDI Verlag GmbH Düsseldorf, 2004.
8. Paul de Mink, "PP in der Thermoformung," Pages 51ff, *Extrudieren und Thermoformen von Verpackungsfolien*, VDI Verlag GmbH Düsseldorf, 2004.
9. Paul de Mink, "PP in der Thermoformung," Pages 57ff, *Extrudieren und Thermoformen von Verpackungsfolien*, VDI Verlag GmbH Düsseldorf, 2004.
10. Paul de Mink, "PP in der Thermoformung," Pages 59ff, *Extrudieren und Thermoformen von Verpackungsfolien*, VDI Verlag GmbH Düsseldorf, 2004.
11. Paul de Mink, PP in der Thermoformung, S. 61 ff, *Extrudieren und Thermoformen von Verpackungsfolien*, VDI Verlag GmbH Düsseldorf 2004. |

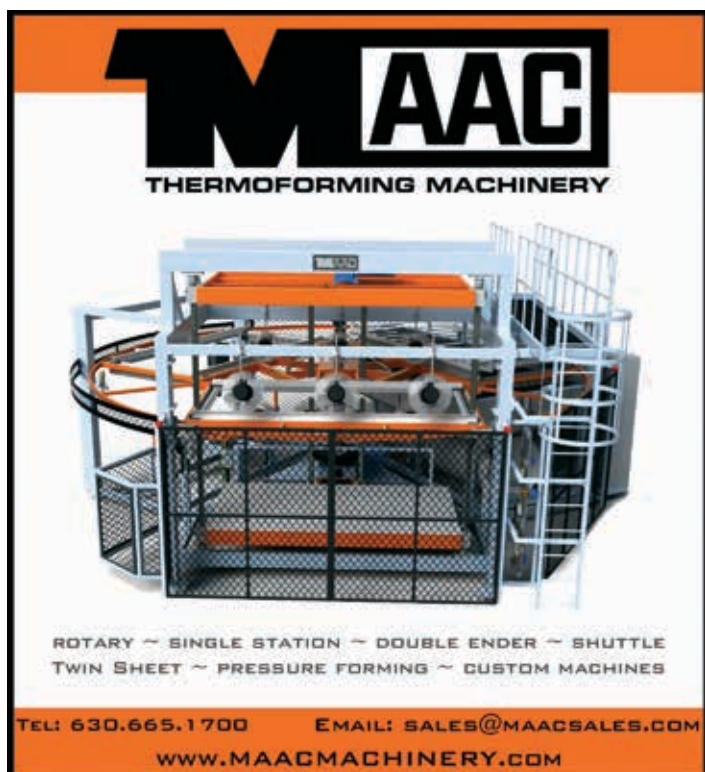

From the Editor

If you are an educator, student or advisor in a college or university with a plastics program, we want to hear from you! The SPE Thermoforming Division has a long and rich tradition of working with academic partners. From scholarships and grants to workforce development programs, the division seeks to promote a stronger bond between industry and academia.

Thermoforming Quarterly is proud to publish news and stories related to the science and business of thermoforming:

- New materials development
- New applications
- Innovative technologies
- Industry partnerships
- New or expanding laboratory facilities
- Endowments

We are also interested in hearing from our members and colleagues around the world. If your school or institution has an international partner, please invite them to submit relevant content. We publish press releases, student essays, photos and technical papers. If you would like to arrange an interview, please contact Conor Carlin, Editor, at cpcarlin@gmail.com or 617-771-3321.

Innovation Before Technology

By Conor Carlin, Editor

Editor's Note: A modified version of this article first appeared in the November/December issue of SPE's Plastics Engineering magazine.

AMI, the organizers of the Thin Wall Packaging Conference, chose the city-state of Singapore as the forum for their first foray into South East Asia. As a key member of the Association of South East Asia Nations (ASEAN), Singapore boasts some impressive statistics: #1 investment destination in Asia, #2 most competitive city in the world, and #3 in GDP per capita (IMF data). According to Bloomberg, it's also the 'least miserable' nation in the world. The former British outpost is now a global financial powerhouse and a hub of trading activity for the region so it made sense to host a regional conference here. With just under 100 attendees from 25 countries, the maiden event attracted suppliers and processors primarily from Europe and Asia, with only two attendees from North America.

The population of the 10 member states of ASEAN is approximately 670 million people which ranks higher than NAFTA and EU-28 as a trading bloc. Purchasing power, however, remains significantly lower on aggregate though growth rates are higher than most western countries. And though the term "South East Asia" was used throughout the event, several presenters drew distinctions among individual countries as the region cannot be considered monolithic. That said, there were a few 'megatrends' that appeared in multiple papers: demographic shifts; inter-material replacement; and ambient vs. chilled packaging. In addition, there were several interesting, unique trends such as the continued importance of PP thermoformed water cups in Indonesia, PP replacing EPS in Malaysia, and how the importance of 7-11 stores in Thailand influenced packaged goods.

As with other TWP conferences, European companies featured prominently in the presentations. For those who have attended multiple events in Cologne and Chicago, it was disappointing to see previously-presented papers, though first-time attendees from the region had the opportunity to learn about the latest updates in T-IML, barrier films and nucleating agents for polypropylene. While the economics of T-IML compare favorable to IML under certain conditions, volume is a critical factor. To date,

the only systems in operation are in Europe and North America.

Representatives from Brueckner Group / Kiefel offered an interesting and nuanced view of the regional market by delving into specific trends in individual countries. The Philippines, for example, with over 100 million people, is more Westernized than other countries due to its colonial history with Spain and the more recent US influence. After being hit with a typhoon in 2009 that resulted in severe floods, the country's drains were clogged and PS cups were identified as a major contributor. The central government decided that only paper cups should be used in the future, thinking that they would more easily degrade, despite studies showing that waste increased with paper use. This led to a mismatch in tolerances between PS lids and new paper cups. The unintended consequence is now that many take-out drinks are sold with a piece of tape securing the lid to the cup.

Malaysia & Indonesia

Over 2 billion lunch boxes are produced each year in Malaysia. Originally made from polystyrene foam, a new directive now mandates a switch to polypropylene. Though EPS offers lightweight parts with good insulation, it cracks easily and, perhaps more importantly, it has proven to be very difficult to recover as part of any recycling program. The moderator, Jon Nash of AMI, keenly pointed out that a certain slide in one of the presentations appeared to claim that PS was linked to cancer without providing any evidence. This topic was also discussed at the 2015 TWP event in Cologne when Dr. Isabelle Ydens bemoaned styrene's image problem, despite the fact that the styrene monomer occurs naturally. Nash took the opportunity to remind the audience that the plastics industry has an obligation to provide data and scientific evidence and to avoid broad statements that can be misinterpreted. The industry faces continued criticism from many quarters, despite mounting evidence that plastics offer impressive environmental benefits when compared to other materials such as paper, metals and glass. Still, the public at large does not appear to be swayed by the philosopher Paracelsus' axiom that it is the dosage that makes the poison.



ASEAN comprises 10 countries with a population of over 600MM people.

Demand for water in Indonesia is 'unlimited' according to several presenters and the statistics would appear to reinforce that claim. With a 1.4% year over year increase in population, over 50% of all drinking water in the country is served via thermoformed PP cups, making Indonesia a key market for thermoforming. Several European OEMs continue to reap the benefits of this demand with dozens of machines and multiple turnkey systems being delivered in recent years. The majority of PP cups are formed on tilt-bed, trim-in-place systems which offers highly accurate and concentric cutting. The tooling for these machines continues to evolve with companies like Bosch Sprang and Marbach enabling faster cycle times through improved cooling and high pressure forming. New high-volume, dual circuit pressure forming valves allow air to flow in and out of the mold cavities for faster speeds and a significant reduction in air consumption and, by extension, operating costs. Automation is increasingly being adopted for rim rolling, sleeving, bagging and final case packing operations.

Energy and labor concerns

With an average energy cost of \$0.135/kwh, the Philippines has the highest electric rates in the region which drives the need for energy efficient equipment. Humidity levels in Indonesia, where factory temperatures can rise to 45°C (113°F), contribute to an increased demand on the electricity infrastructure where voltage fluctuations can create risks for equipment and workers. Labor costs continue to rise in several countries. The Malaysian

government stopped the practice of hiring foreign workers which has led to increased investments in faster, more energy-efficient systems. Kiefel described how the increased demand for turnkey solutions and more automation in the region was a factor in their decision to acquire toolmaker Bosch Sprang and automation specialist Mould & Matic this year.

PP gains at the expense of PS

There is no doubt that PP continues to be an important material in thin wall packaging, both as a replacement for existing polymers (PET, PS) and other materials (glass, tin, paper). Versatile, low density, easy to recycle with a relatively low environmental footprint (in terms of water and energy inputs) and a higher energy recovery rate, PP scores high all across the value chain. Speakers from Milliken Chemical (China) and Borouge (Singapore) extolled the virtues of polyolefins while presenting impressive facts on rates of growth in India, China and ASEAN markets. Beyond food and dairy packaging, PP is finding greater adoption in other sectors such industrial paints and lubricants where it is replacing traditional tin and steel containers. In terms of sustainability, PP is very much in favor and is helping to build foundational planks for local circular economies.

Borouge presented a case study illustrating how the addition of their Borstar Nucleation Technology (BNT) to injection-grade propylene was a factor in one company's decision to switch from EPS to PP for a noodle cup. BNT increases the crystallization rate, is isotropic and enhances stiffness which increases the potential for downgauging. Milliken Chemical also highlighted how thin-wall injection molded parts ("TWIP") made with their nucleated PP are replacing PS takeaway containers in both China and Japan. In an interesting note, because Japan taxes plastic parts by weight, the lower density of PP means more parts can be produced from the same amount of material, reducing the tax liability for converters.

In food packaging, wherever there is PP film, EVOH almost certainly follows. Representatives from Kuraray presented data illustrating how multilayer films with EVOH layers improve shelf life by effectively reducing oxygen transmission rates (OTR). According to the company, 1mm of EVAL (Kuraray's trade name for EVOH) has the same gas barrier as a 10-meter thick wall of LDPE. EVOH can be applied in different grades for different applications from

Global PP will grow 4% with Asia and South America growing the fastest

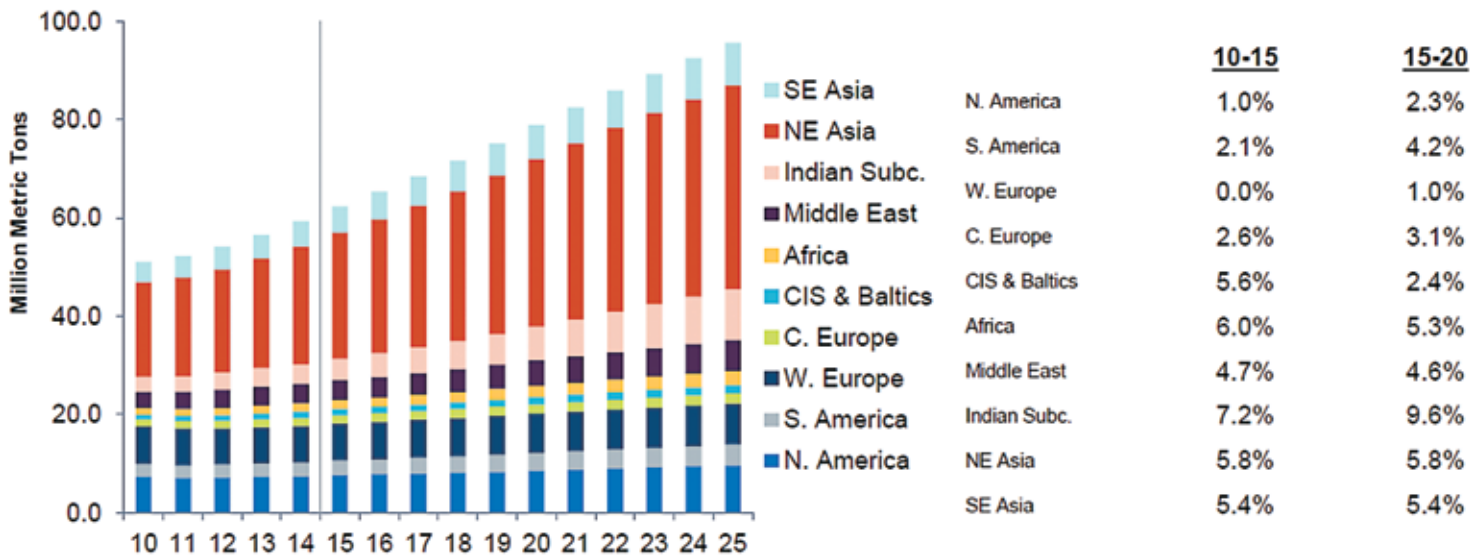

Source: IHS

fuel tanks to extrusion coating to shrink films. Silgan Food Containers described how they incorporated EVOH into their 7-layer PP films that is formed in the melt phase of their proprietary rotary thermoforming process. Because the EVOH is less than 5% of the sheet, it does not affect the recycling stream which allows the company to take advantage of the #5 recycling symbol.

PET and recycling concerns

Representatives from Austria-based extrusion technology firm SML discussed how the physical properties of PET sheet influence discrete processes for thin wall packaging. Because PET is hygroscopic and must be dried prior to extrusion, factory conditions play a critical role in whether or not a converter will be able to offer value-added services such as lamination. SML see a trend toward bigger cups in several ASEAN markets which requires a stronger, thicker sheet. Thinner sheet, by comparison, increases the probability of roll deflection and can lead to non-uniform sheet thickness. For the moment, recycling rates remain low in Asia despite increases in plastics production. According to several panel members, the development of thin wall packaging will be accelerated though better recycling infrastructure and closer cooperation along the supply chain.

The Thai Packaging Association offered some updates on standards development, though with 10 countries trying to find harmonization across markets in different stages of maturity, it was clear that more remains to be done. There are 9 working groups in the food packaging sector alone. The ASEAN Consultative Committee on Standards & Quality (ACCSQ) is using FDA, CE and JETRO regulations for guidance. And though PE/PET lamination is not prevalent in SE Asia, the regulatory environment is in its early stages so there are no defined limits for post-consumer content in PET.

Convergence of megatrends

One anecdote from the panel discussion neatly encapsulated the convergence of several trends, both packaging and demographic, in SE Asia. In Thailand, 7-11 stores have become more of a meeting place than a simple convenience store. People will often work in stores with cell phones or laptops which increases the likelihood that they will purchase and eat something while there. Space is a premium in these small shops with refrigerators eating up valuable real estate and expensive energy. Because barrier films increase the shelf life of foods, many of these store owners are putting more ambient temperature items on the shelves while reducing the inventory of chilled foods.

**EXHIBIT AT
RE|FOCUS 2017**



LET'S RE|DEFINE PLASTICS MANUFACTURING.

Now more than ever, sustainability and recycling solutions aren't limited to plastic packaging. Join us at the Refocus Summit to re|define the way you think about plastics in manufacturing and more.

PLASTICS  **REFOCUS**
INDUSTRY ASSOCIATION SUSTAINABILITY & RECYCLING SUMMIT

WITH THE SUSTAINABILITY DIVISION OF SPE, PRINCIPAL PROGRAMMING PARTNER

©2017 Plastics Industry Association (PIA.org)

June 27–29, 2017 | Rosen Shingle Creek | Orlando, FL • Learn more at refocussummit.org

Printpack India also discussed how this shift to high-barrier, high-clarity containers, both thermoformed and injection molded, signaled a move away from glass containers despite the premium factor associated with glass and its lower cost. In one study, the newer plastic formats did not cannibalize existing glass containers, but rather led to an expansion of the market into new segments such as schools and offices where safety concerns are more pronounced. Beyond hot soups and noodle dishes, additional trends toward minimally-processed foods mean that convenience stores have more SKUs to display. And though the topic was discussed in only a teasing fashion, the impact of online delivery services for food could affect the requirements for packaging and transport. Will consumers still expect a high level of decoration (IML or otherwise) on items that they have only previously seen online?

Innovation vs technology

Nash posited that plastic consumption increases after \$5-10k per capita and plateaus at \$30k. These figures are

based on AMI's extensive global market research in thin wall packaging. Given the relative sizes of purchasing power in the various ASEAN countries, coupled with demographic trends favoring urban migration and the associated increase in convenience eating, the stage is set for increased growth in most ASEAN countries. So what are the critical success factors for specific end-use applications? In both panel discussions, AMI seeded the sessions with questions like these to prime the conversation. On the theme of inter-material replacement, the moderator asked about the drivers behind brands' decision to select barrier plastic packaging. Two main responses emerged: the first was about adding value to the product, particularly in terms of functionality (think squeezable ketchup bottles instead of tapping the "57" logo on a glass version); the second was to extend shelf life, for both long transportation cycles and in-home usage.

In a 'design-led journey' for packaging, a speaker from qDesign, an Australian multidisciplinary design firm, described how human-centered design thinking can

Rigid packaging consumption by polymer

Polyolefin with high value to cost position will surpass growth and replace others less sustainable plastic materials

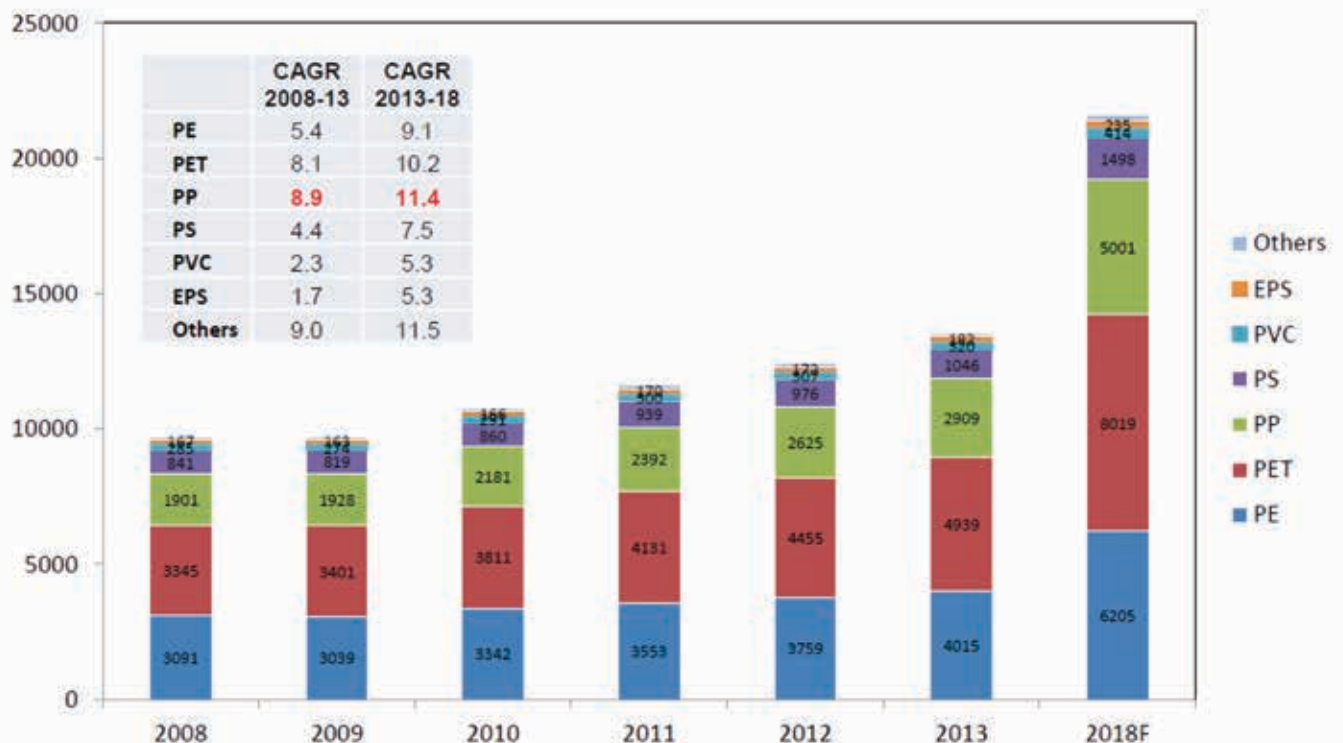
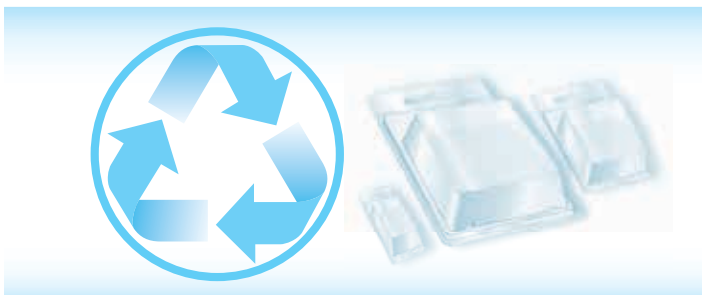

Chart courtesy of Borouge Pte Ltd, originally presented at AMI TWP Asia.

influence packaging in new ways. The case in point was a redesign of Gourmet Garden's fresh herbs which are packaged in a tube. The original intent was to avoid spoilage of fresh herbs which many consumers would buy, use once, then store in the fridge until they wilted. Diving deeper into the consumer experience, the designers discovered that using herbs imparted a sense of culinary élan and transformed the average household cook into a Michelin-starred chef, if only for a few seconds. This insight led to a complete change in package format for dried herbs, moving from a tube to a 'system' of interlocking tubs with large openings for fingers to easily grab and sprinkle cilantro, basil, coriander and ginger. Proving that innovative packaging leads to an increase in purchases, Gourmet Garden reported a 60% jump in category sales after the new design was introduced. The story served as an important reminder that innovation will often trump technology in terms of understanding market needs. Eye-catching technology will draw a crowd into a tradeshow booth, but solving customer problems through innovation and supply chain collaboration will ultimately drive sales.

One size does not fit all

While large Asian converters are importing (mainly) European technology for packaging needs, global trends are not exactly uniform, though it could be said that technology platforms and possibly material developments are converging. North American and European countries feature high rates of supermarket penetration, associated transportation chains and aging populations that demand more, and more from, packaged goods. Other regions, including ASEAN, do not have such high ratios of supermarkets to people, with smaller convenience stores and street vendors providing food to increasingly young and urban consumers. And though the region itself is large, there are several discrete trends among the countries which offer opportunities for innovative thinking. As the data from the event suggests, increasing growth rates and rising disposable incomes will continue to drive consumption of plastic packaging. |



Become a SPE Thermoforming Quarterly Sponsor in 2017!

**Sponsorship opportunities
include 4-color, full page, and
1/2 page ad spaces.**

**RESERVE YOUR PRIME
SPONSORSHIP SPACE TODAY.**

Questions? Call or email

Lesley Kyle

914-671-9524

lesley@openmindworks.com

Thermoforming Division Membership Benefits

- Access to industry knowledge from one central location: www.thermoformingdivision.com.
- Subscription to Thermoforming Quarterly, voted "Publication of the Year" by SPE National.
- Exposure to new ideas and trends from across the globe
- New and innovative part design at the Parts Competition.
- Open dialogue with the entire industry at the annual conference.
- Discounts, discounts, discounts on books, seminars and conferences.
- For managers: workshops and presentations tailored specifically to the needs of your operators.
- For operators: workshops and presentations that will send you home with new tools to improve your performance, make your job easier and help the company's bottom line.

In Memoriam: Stephen J. Sweig



We are saddened to pass on the news of the death of Stephen J. Sweig.

Stephen had been a driving force of process and tooling innovation in heavy gauge thermoforming as the Chief Engineer at Profile Plastics for the last 30 years. Although “semi-retired” for many years, Stephen remained active in the business, working on new projects and process upgrades up until his death.

He is singularly responsible for many innovations in thermoforming machinery and process technology over the years, many that are now considered ‘standard equipment.’ He was also influential in the development of 5-axis trimming for plastics parts. Stephen holds a US patent for Double Sided Pressure Forming, and worked with Glenn Bealle to create the first Pressure Forming Design Guide in 1985.



1943 – 2017

Starting at Arrem Plastics, which Profile later acquired in 2002, Stephen was at the forefront of developing the Pressure Forming process from a garage-shop idea to the fully commercialized, and widely accepted, process that it is today. He worked with toolmakers and machinery builders to push the envelope of what features could be molded-in, many of which had ‘never been done before.’ He also has been influential in expanding the capabilities of the twin sheet process, allowing for ever more complex part geometries and developing cost effective ways to align the molds during forming.

He was a respected member of the SPE Thermoforming community, having attended and presented at the annual conference regularly. He was recognized for his achievements as the recipient of the Thermoformer of the Year in 2002.

Stephen was an engineer’s engineer, always backing up his ideas with detailed calculations and ensuring a safe workplace for all. His passion, creativity, intellect and institutional knowledge will definitely be missed. |

He is singularly responsible for many innovations in thermoforming machinery and process technology over the years, many that are now considered ‘standard equipment.’



SPE PLASTIVAN™ PROGRAM

● SPE PLASTIVAN™ SPONSORSHIP

With a national focus on STEM disciplines at all educational levels, both private and public resources are being marshalled to address a shortage of skilled employees across manufacturing industries. It is critical for plastics and related companies to be active in their communities, both to demonstrate career opportunities and to promote the benefits of plastics which are often misunderstood.

The PlastiVan™ Program is a great way to excite young people about the science and the vast opportunities the plastics industry has to offer. The program travels to schools and companies throughout North America, educating middle- and high-school students about plastics chemistry, history, processing, manufacturing, sustainability and applications. Corporate sponsors have a unique role to play in this community outreach program, linking the wonders of plastics to applications and jobs in the real world.

● COSTS OF SPONSORSHIP

The fee for the PlastiVan™ program is \$1500 a day. Your sponsorship covers travel & expenses for educators as well as all materials. SPE coordinates all scheduling and communication with schools. This allows more students greater access to the wonders of plastics in their own communities. Sponsorship of the PlastiVan™ Outreach Education Program is a tax-deductible donation.



● BENEFITS OF SPONSORSHIP

As part of the sponsorship package, companies gain access to students, parents and educators in local communities. Sponsoring companies can choose to provide a list of local schools or SPE staff can work with you to select schools and arrange schedules. Many companies choose to send a representative to speak directly to the audience about products and career opportunities. In addition, SPE can help coordinate PR with local press to craft stories about the PlastiVan™ visit. These stories are then added to SPE's library of testimonials highlighting the success of the PlastiVan™ program.

BECOME A SPONSOR TODAY!

For more information or to schedule a school visit, contact:

Deb Zaengle

PH: +1 203.740-5417

dzaengle@4spe.org



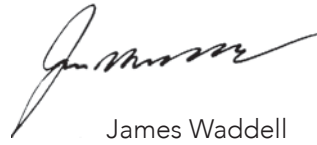

James Waddell

Greetings!

Since the last report, the Council held a remote meeting on December 7, 2016, to update financial information, to describe new services coming on-line, and to amend the By-Laws.

As you will all know by now, SPE CEO, Wim De Vos, will not be renewing his contract and will return to the plastic industry. If you are interested, the job description is on the SPE website!

Organization finances remain an issue as operational losses continue due to below-budgeted revenue for membership and advertising costs. These declines were somewhat offset by expenses that came in under budget, but the bottom line is still a six-figure loss.

SPE has several new programs to help offset the loss of membership income.

New TOPCONS (topical conferences) will be coming soon, sponsored by SPE and other partners including JEC (composites) and PLASTICS (formerly SPI):

- a. Medical Plastics Europe (March 2017, Brussels)
- b. Plastics in Construction (June 2017, Chicago)
- c. 3-DP / Additive Manufacturing (August 2017, Indianapolis)
- d. ReFocus (June 2017, Orlando)
- e. Injection Molding USA (August 2017, Chicago)
- f. Design in Plastics: Additives and New Materials (November 2017, Detroit)

In addition, there are some new initiatives for reaching out to companies:

- a. Value-chain seminars for companies
- b. Targeted/dedicated e-mail sends
- c. Strategic market surveys

- d. Technology awareness articles
- e. Corporate webinars
- f. Innovation platform / Innovation partner
- g. Plastic race app

These programs are being targeted towards a pipeline of 498 companies. If, for example, you paid for 100% of these services at full price, the income would be \$846K. At this time, there are \$400K in offers that have been presented and under discussion. Another \$192K is identified as having a high probability of being closed.

SPE is also upgrading its technology to provide better service to its members. The financial impact for 2017 is around \$62K out of \$98K in costs. This might seem like a lot, but these upgrades are designed to provide better information and services to a global membership with varying needs.

SPE has embarked upon a reassessment of several core questions:

“Why should you be a member of SPE?”

“What do you want from SPE ?” and

“How can SPE give better value for your membership?”

To assist in this effort, Divisions and Sections are being surveyed by members of Council to get their input. If you have any thoughts on this, please drop me an email or join the discussion on The Chain. |

James

WORLD WIDE LEADER IN PS THERMOFORMING MACHINERY, TOOLING AND GRANULATION.



IRWIN

Research & Development, Inc

Phone: (509)248-0194 • Fax: (509)248-3503

www.irwinresearch.com • Email: sales@irwinresearch.com

2017 THERMOFORMING DIVISION ORGANIZATIONAL CHART

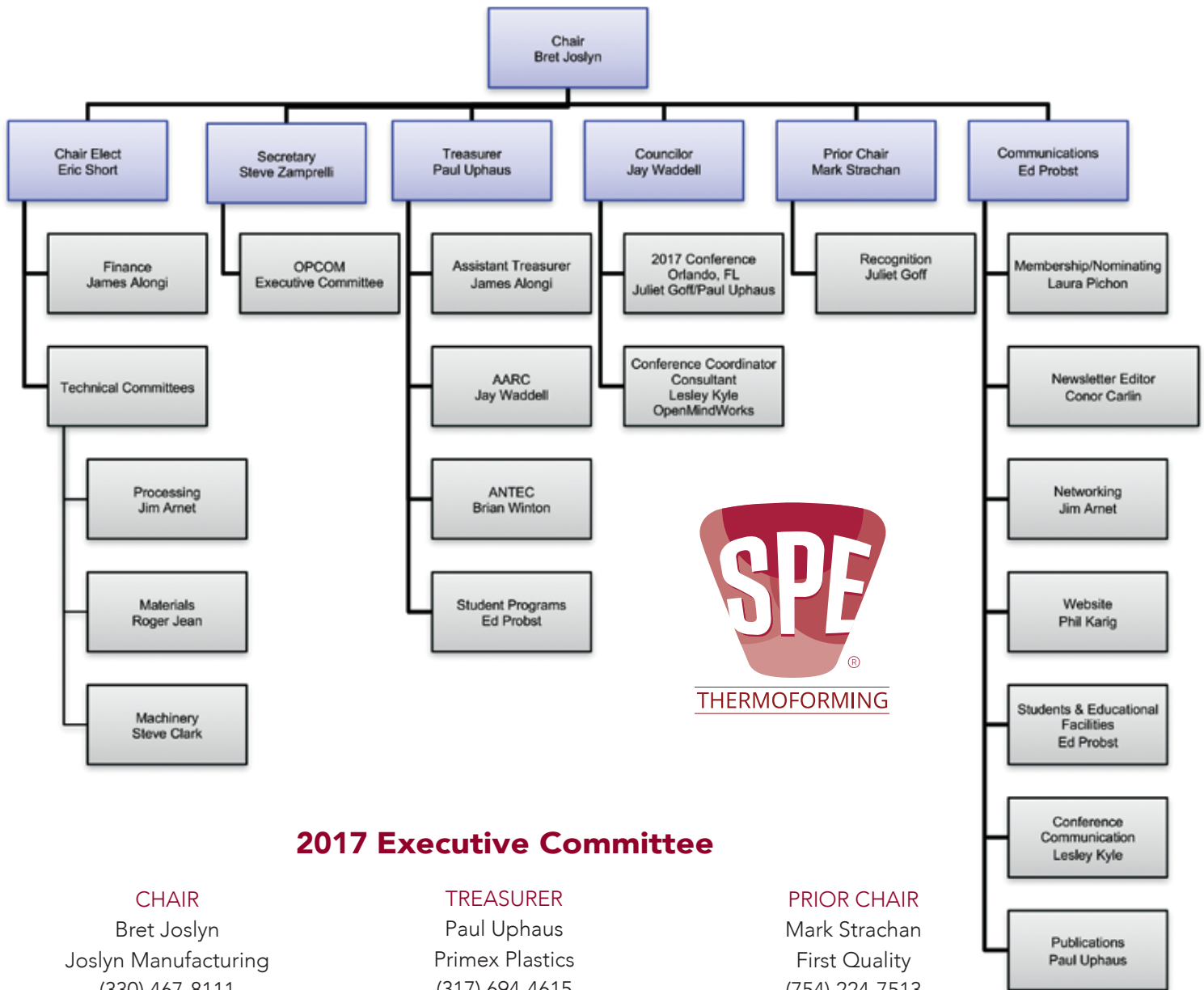

2017 Executive Committee

CHAIR

Bret Joslyn
Joslyn Manufacturing
(330) 467-8111
bret@joslyn-mfg.com

TREASURER

Paul Uphaus
Primex Plastics
(317) 694-4615
puphaus@primexplastics.com

PRIOR CHAIR

Mark Strachan
First Quality
(754) 224-7513
mark@global-tti.com

CHAIR ELECT

Eric Short
Premier Material Concepts
(248) 705-2830
eshort@buypmc.com

COMMUNICATIONS

Ed Probst
Probst Plastics
(414) 476-3096
ed.probst@probstplastics.com

COUNCILOR WITH TERM ENDING 2018

Jay Waddell
Plastics Concepts & Innovations
(843) 971-7833
jwaddell@plasticconcepts.com

SECRETARY

Steve Zamprelli
Formed Plastics, Inc.
(516) 334-2300
s.zamprelli@formedplastics.com

Upcoming SPE Thermoforming Division Board Meetings

May 4 - 6 • Indianapolis, Indiana

For more information, contact Lesley Kyle:
lesley@openmindworks.com or 914-671-9524

MACHINERY COMMITTEE

James Alongi
MAAC Machinery
590 Tower Blvd.
Carol Stream, IL 60188
T: 630.665.1700
F: 630.665.7799
jalongi@maacmachinery.com

Steven Clark (Chair)
Monark Equipment
PO Box 335
4533 S. Garfield Road
Auburn, MI 48611
T: 989.662.7250
F: 989.614.3539
sclark@monark-equip.com

Brian Golden
SencorpWhite
400 Kidd's Hill Road
Hyannis, MA 02601
T: 508.771.9400
bgolden@sencorpwhite.com

Travis Kieffer
Plastics Unlimited, Inc.
303 1st St. N.W.
Preston, IA 52069
T: 563.589.4752
TravisK@plasticsunlimited.com

Brian Winton
Lyle Industries, Inc.
4144 W. Lyle Road
Beaverton, MI 48612
T: 989.435.7714 x 32
F: 989.435.7250
bwinton@lyleindustries.com

MATERIALS COMMITTEE

Jim Armor
Armor & Associates
16181 Santa Barbara Lane
Huntington Beach, CA 92649
T: 714.846.7000
F: 714.846.7001
jimarmor@aol.com

Juliet Goff
Kal Plastics
2050 East 48th Street
Vernon, CA 90058-2022
T: 323.581.6194
juliet@kal-plastics.com

Roger P. Jean (Chair)
Rowmark/PMC
PO Box 1605
2040 Industrial Drive
Findlay, OH 45840
T: 567.208.9758
rjean@buypmc.com

Phillip Karig
Mathelin Bay Associates LLC
11939 Manchester Road #148
Saint Louis, MO 63131
T: 314.630.8384
karig@mathelinbay.com

Ian Munnoch
MSA Components, Inc.
5662 E. St. Rd. 54
Bloomfield, IN 47424
T: 812.322.5080
imunnoch@msacomponents.com

Matt O'Hagan
LyondellBasell
7674 Park Meadow Lane
West Bloomfield, MI 48324
T: 248.760.8590
matt.ohagan@lyondellbasell.com

Laura Pichon
Ex-Tech Plastics
PO Box 576
11413 Burlington Road
Richmond, IL 60071
T: 847.829.8124
F: 815.678.4248
lpichon@extechplastics.com

Ed Probst
Probst Plastics Consulting
P.O. Box 26365
Wauwatosa, WI 53226
T: 414.476.3096
ed.probst@probstplastics.com

Eric Short
Premier Material Concepts
11165 Horton Road
Holly, Michigan 48442
T: 248.705.2830
eshort@buypmc.com

Paul Uphaus
Primex Plastics
4164 Lake Oconee Drive
Buford, GA 30519
T: 1.800.935.9272
F: 800.935.0273
puphaus@primexplastics.com

PROCESSING COMMITTEE

Jim Arnet (Chair)
Hagans Plastics Co.
121 W. Rock Island Road
Grand Prairie, TX 75050
T: 972.974.3516
jarnet@hagansus.com

Robert Browning
McConnell Company
P.O. Box 450633
Atlanta, GA 31145
T: 770.939.4497
F: 770.938.0393
robert@thermoformingmc.com

Ken Griep
Portage Casting & Mold
2901 Portage Road
Portage, WI 53901
T: 608.742.7137
F: 608.742.2199
ken@pcmwi.com

Bret Joslyn
Joslyn Manufacturing
9400 Valley View Road
Macedonia, OH 44056
T: 330.467.8111
F: 330.467.6574
bret@joslyn-mfg.com

Stephen Murrill
Profile Plastics
65 S. Waukegan
Lake Bluff, IL 60044
T: 847.604.5100 x29
F: 847.604.8030
smurrill@thermoform.com

Mark Strachan
First Quality
T: 754.224.7513
mark@global-tti.com

Jay Waddell
Plastics Concepts & Innovations
1127 Queensborough Road
Suite 102
Mt. Pleasant, SC 29464
T: 843.971.7833
F: 843.216.6151
jwaddell@plasticconcepts.com

Steve Zamprelli
Formed Plastics, Inc.
297 Stonehinge Lane
Carle Place, NY 11514
T: 516.334.2300
s.zamprelli@formedplastics.com

DIRECTORS EMERITI

Art Buckel
McConnell Company
3452 Bayonne Drive
San Diego, CA 92109
T: 858.273.9620
artbuckel@thermoformingmc.com

Lola Carere
302 Sable Trace Ct.
Acworth, GA 30102-7617
T: 770.883.7055
carerelola@comcast.net

Richard Freeman
Freetech Plastics Inc.
2211 Warm Springs Court
Fremont, CA 94539
T: 510.651.9996
rfree@freetechplastics.com

Steve Hasselbach
CMI Plastics
222 Pepsi Way
Ayden, NC 28416
T: 252.746.2171
F: 252.746.2172
steve@cmiplastics.com

Donald Hylton
McConnell Company
646 Holyfield Highway
Fairburn, GA 30213
T: 678.772.5008
don@thermoformingmc.com

Roger Kipp
Roger C. Kipp Consulting
3C Owens Landing Court
Perryville, MD 21903
T: 717.521.9254
srkipp@msn.com

Gwen Mathis
6 S. Second Street SE
Lindale, GA 30147
T: 706.346.2786
gmathis224@aol.com

Stan Rosen
10209 Button Willow Drive
Las Vegas, NV 89134
T: 702.869.0840
thermoipp@earthlink.net

These sponsors enable us to publish *SPE Thermoforming Quarterly*

■ Advanced Extruder Technologies	23
■ Brown Machinery	33
■ CMT Materials.....	27
■ Formed Plastics.....	37
■ GN Thermoforming Equipment.....	7
■ Illig	19
■ Irwin Research & Development	47
■ MAAC Machinery.....	37
■ O.M.G. SRL.....	13
■ Premier Material Concepts.....	35
■ Polytype America Corp.	11
■ Portage Casting & Mold	27
■ Profile Plastics.	27
■ PTi Extruders	Back Cover
■ Sekisui Polymer Innovations, LLC.....	Inside Front Cover
■ Siemens	Inside Back Cover
■ Solar Products	6
■ Thermoformer Parts Suppliers.....	6
■ TSL	25

Need help with your technical school or college expenses?

If you or someone you know is working towards a career in the plastic industry, let the SPE Thermoforming Division help support those education goals.

Here is a partial list of schools and colleges whose students have benefited from the Thermoforming Division Scholarship Program:

- UMASS Lowell
- San Jose State
- Pittsburg State
- Penn State Erie
- University of Wisconsin
- Michigan State
- Ferris State
- Madison Technical College
- Clemson University
- Illinois State
- Penn College

Start by completing the application forms at www.thermoformingdivision.com or at www.4spe.org





SIEMENS
Ingenuity for life

Engineering with TIA Portal

Heat under control

SIPLUS HCS – I/O systems for industrial heating applications

When temperature control counts, you can count on Siemens. For over 25 years, SIPLUS HCS heating control systems from Siemens have helped to ensure that heat is regulated precisely. The I/O systems control electrical heating elements for 230 V/277 V or 400 V/480 V networks. They also save energy, space, wiring and engineering time.

siemens.com/siplus-hcs

© 2017 Siemens Industry, Inc.

SHEET EXTRUSION TECHNOLOGY LEADER SUPER-G® HIGH SPEED EXTRUDERS

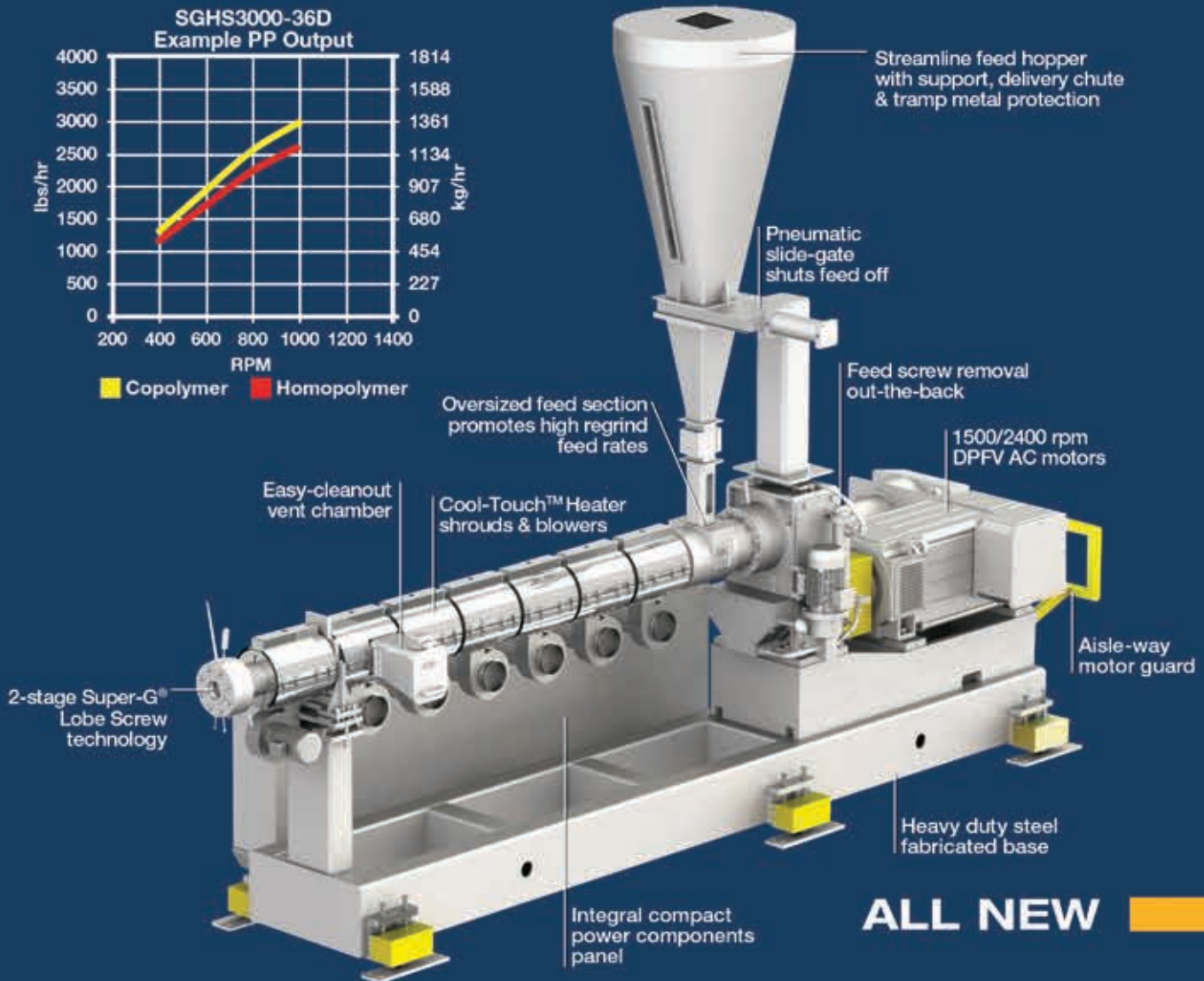

ALL NEW

- AVAILABLE IN 2 SIZES SGHS3000-36D & -42D
- COMPACT MACHINE FOOTPRINT
- ENERGY EFFICIENT (PP 6-7+ PPH/HP)
- EXCELLENT MELT QUALITY (SUPER-G® LOBE)
- HIGH REGRIND RECOVERY (UP TO 70+%)
- AVAILABLE WITH ALL PTI ROLL STAND CONFIGURATIONS
- COST EFFECTIVE PP & HIPS SOLUTION!



World Class Sheet Extrusion Systems
www.ptiextruders.com