



# Thermoforming Quarterly®

Fourth Quarter 2018 | Volume 37 | Number 4

A Journal of the Thermoforming Division of SPE

The background of the cover features two white medical carts on wheels, positioned in a room with blue curtains. One cart is in the foreground, and another is slightly behind it to the left. The text 'thermoformingdiv' is visible on the side of the cart in the background.

Just  
What  
the  
Doctor  
Ordered

## IN THIS ISSUE:

*2018 Thermoforming  
Conference Review*

*Innovation Takes Root  
in California*

*SPE Parts Competition  
and Winners*

# G-SERIES® QuadPLUS™

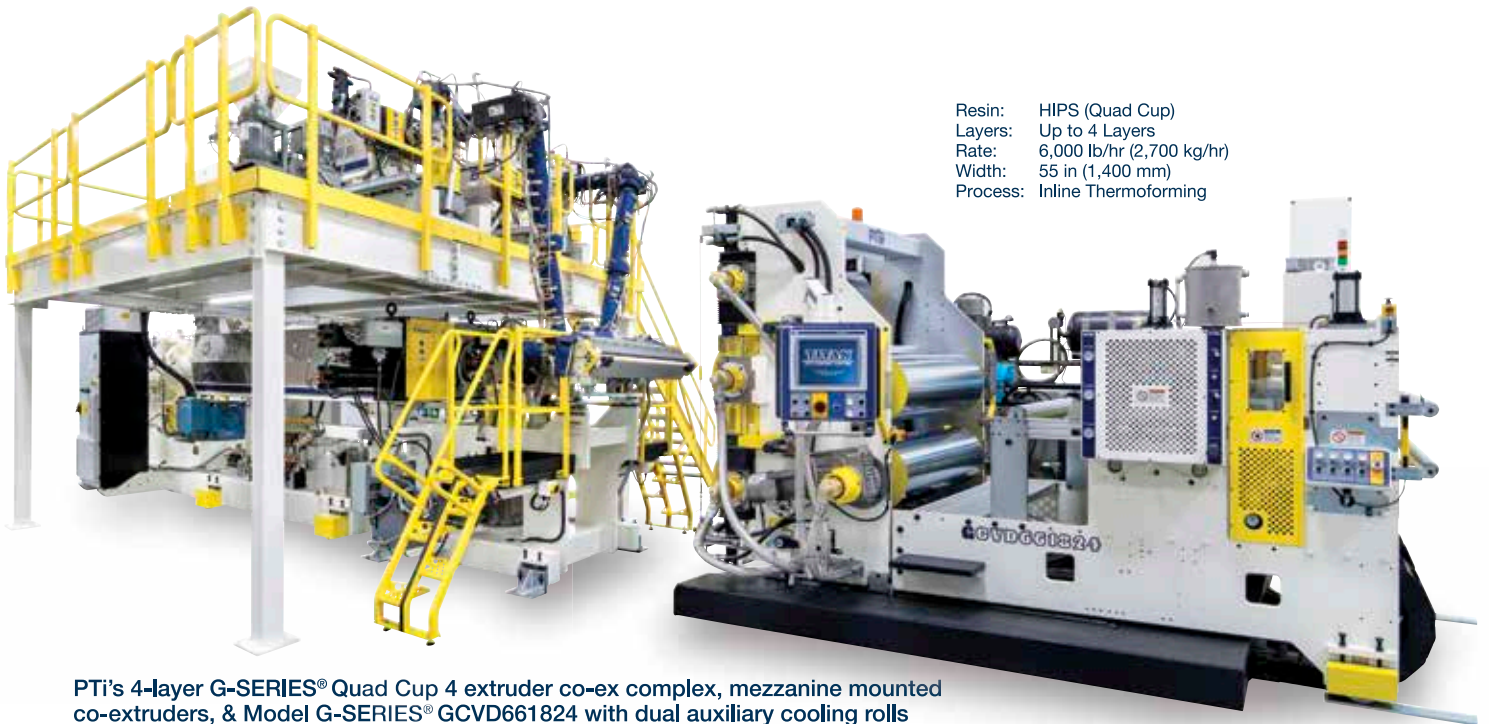

Resin: HIPS (Quad Cup)  
 Layers: Up to 4 Layers  
 Rate: 6,000 lb/hr (2,700 kg/hr)  
 Width: 55 in (1,400 mm)  
 Process: Inline Thermoforming

PTi's 4-layer G-SERIES® Quad Cup 4 extruder co-ex complex, mezzanine mounted co-extruders, & Model G-SERIES® GCVD661824 with dual auxiliary cooling rolls

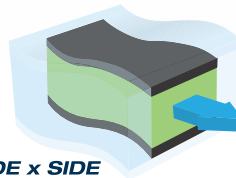
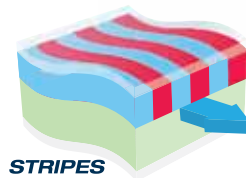
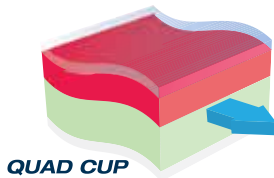

Special low-friction adapter piping and sheet die feature insulation blankets for high energy efficiency and operator safety.



Low-boy co-extruders positioned on a mezzanine assure easy operator access to the extrusion complex and a compact footprint.



G-SERIES® configurable 5-roll compact vertical roll stand features high efficiency temperature control modules and open operator access.

- **MEZZANINE CO-EXTRUDERS/ COMPACT MACHINE FOOTPRINT**
- **HIGH RATES OF PRODUCTION/ MANY SIZES AVAILABLE**
- **TITAN® CONTROLS AUTOMATION FOR EASE OF OPERATION**

- **MULTI-RESIN PROCESS CAPABILITIES (PP, PS, HDPE, ...)**
- **QUAD CUP, SIDE X SIDE, BARRIER & STRIPE CONFIGURATIONS**
- **SEVERAL ADVANCED OPTIONS TO CHOOSE FROM!**



World Class **Sheet Extrusion** Systems  
[www.ptiextruders.com](http://www.ptiextruders.com)

Processing Technologies International, LLC | 2655 White Oak Circle Aurora, IL 60502 | Tel: 630.585.5800 | Fax: 630.585.5855

## ■ Departments

Chairman's Corner | **4**

Thermoforming in the News | **6-8**

University News | **10-14**

Global Dispatches: Innovation Takes  
Root in California | **30-33**

In Memoriam | **38**

## ■ Features

2018 Thermoforming Conference Review | **18-19**

Conference Parts Competition Winners | **20-25**

Toolvision GmbH Develops Technology to Optimize  
Thermoforming Process | **28-29**

## ■ In This Issue

Thermoforming & Sustainability | **34**

SPE News | **36-37**



Cover image: Profile Plastics medical cart enclosure.  
Courtesy Dallager Photography.

A JOURNAL PUBLISHED EACH  
CALENDAR QUARTER BY THE  
THERMOFORMING DIVISION  
OF THE SOCIETY OF  
PLASTICS ENGINEERS

[www.thermoformingdivision.com](http://www.thermoformingdivision.com)

### Editor

**Conor Carlin**

(617) 771-3321

[cpcarlin@gmail.com](mailto:cpcarlin@gmail.com)

### Sponsorships

**Lesley Kyle**

(914) 671-9524

[lesley@openmindworks.com](mailto:lesley@openmindworks.com)

### Conference Coordinator

**Lesley Kyle**

(914) 671-9524

[lesley@openmindworks.com](mailto:lesley@openmindworks.com)

**SPE Thermoforming Quarterly**® is published four times annually as an informational and educational bulletin to the members of the Society of Plastics Engineers, Thermoforming Division, and the thermoforming industry. The name, "**SPE Thermoforming Quarterly**"® and its logotype, are registered trademarks of the Thermoforming Division of the Society of Plastics Engineers, Inc. No part of this publication may be reproduced in any form or by any means without prior written permission of the publisher, copyright holder. Opinions of the authors are their own, and the publishers cannot be held responsible for opinions or representations of the authors. Printed in the U.S.A.

**SPE Thermoforming Quarterly**® is registered in the U.S. Patent and Trademark Office (Registration no. 2,229,747). |

# Annual Conference of Firsts



Eric Short



The 4th Quarter edition of our magazine is usually when we feature a review of our annual conference and this issue is no different. With an outstanding array of parts competition winners (wonderfully captured by Ellen Dallager, our long-time photographer) the 2018 conference highlighted many new innovations that embody the spirit of thermoforming. The magazine cover features the People's Choice Award, won this year by Profile Plastics. As described in the submission, this medical cart enclosure featured minimal attachment points enabled by unique tooling design with moving parts. Indeed, many of the winning parts demonstrated the benefits of the thermoforming process, by taking advantage of molded-in components or extruded sheet with cosmetic appearance. Congratulations to the winners, and thank you to those who submitted parts and those that helped to organize the competition.

The conference in Ft. Worth represented a number of firsts for the SPE Thermoforming Division: our first time in Texas; our first time with a Conference Chairman on a horse; and the first successful student remote-controlled (RC) car race, which resulted in cash and prizes for the team from the University of Georgia. The cars, all with thermoformed body panels, zipped (or flipped, or tipped) around the track, each round providing faster and faster times. Younger students from local schools were treated to the SPE PlastiVan™ demonstrations which illustrate both the basic principles of polymers and the ways in which we depend on plastics for our daily lives.

Plastics and sustainability continue to loom large in our industry today, with global corporations and governments

struggling to balance the benefits and risks of polymer-based materials. While larger entities work on policies, at the local level, some companies are taking action to improve their triple bottom line of people, planet and profit (see story on Merrill's Packaging on pp. 34). From a resin perspective, our editor reports from California on the growth and expansion of NatureWorks' Ingeo PLA platform. Thanks to sustained investment over the past 15 years, the Minnesota-based company has cultivated an ecosystem that stretches from the cornfield to the inside of your refrigerator (see story on pp. 30).

As the conference dinner in AT&T Stadium showed, our annual event takes a lot of work from our dedicated volunteers and our wonderful sponsors. On behalf of the Board of Directors, thank you again for your support! Our division remains one of the strongest within SPE, due in large part to our sense of community and our ability to attract and retain both members and board volunteers.

Before we start talking about Milwaukee in 2019, be sure to head to Detroit in March for ANTEC, SPE's flagship technical conference. Many breakthroughs in plastics engineering are first announced here, from both academic and corporate sources.

Here's to a strong finish to 2018, a safe and enjoyable holiday season, and a to a prosperous 2019!

Yours,  
Eric |



## **ADVANCED EXTRUDER TECHNOLOGIES**

**Design | Engineering | Manufacturing**



### **CUSTOM, SHEET EXTRUSION SYSTEM DRYER-LESS, PET / PLA SHEET EXTRUSION SYSTEM**

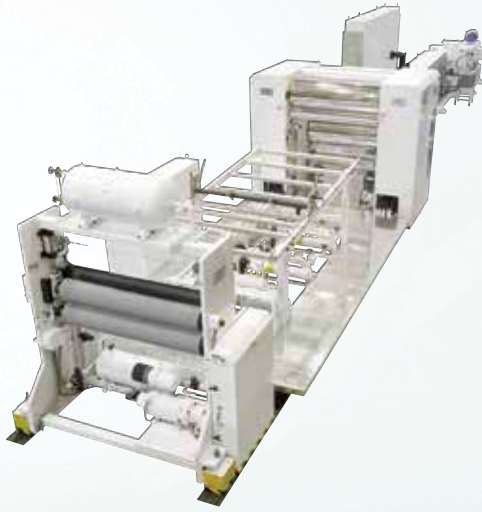

- High Performance
- Low Melt Temperature
- Short Dwell Time
- Excellent Mixing
- Low Energy Consumption
- High Vacuum System
- In-line IV Monitoring/Control System
- Compact Design
- Robust Design
- FDA Approved

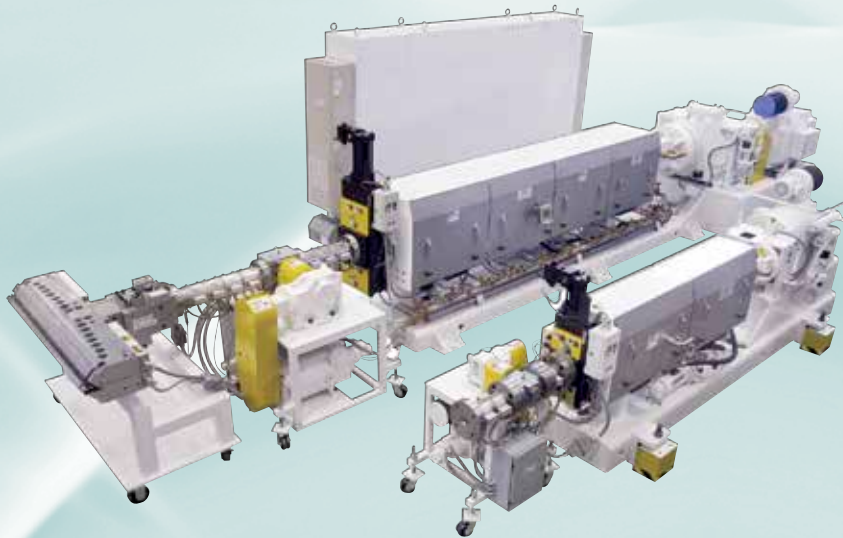

- Mono Layer- Barrier Co Extrusion
- Thin Gauge – Heavy Gauge
- Extruder Size: 1.5”- 15” In Screw Dia.
- Quick Roll Change Design
- Custom Configuration
- Servo Driven
- Independently Driven
- Roll Diameter: 12”- 40”
- Face Width: 36”- 150”
- State-of-the-Art HMI Control System
- Unparallel Customer Service & Support
- Technology Driven



**ADVANCED EXTRUDER TECHNOLOGIES, INC.**  
Commitment to Excellence

2281 East Devon, Elk Grove village IL. 60007 Tel: 847-238-9651 Fax: 847-238-9654 [www.aetextruder.com](http://www.aetextruder.com)

## Rohrer Buys Retail Packaging Maker Transparent Container

By *Canadian Plastics*

October 2, 2018 – In a move that adds six manufacturing locations to its operations, packaging supplier Rohrer Corp. has acquired retail packaging manufacturer Transparent Container for an undisclosed amount.

Headquartered in Addison, Ill., Transparent Container designs and manufactures blister and club packaging, clamshells, and printed plastic and paperboard folding cartons.

“This acquisition provides [us] with additional thermoforming capacity, expanded product range, and the largest combination run program for printed and thermoformed visual packaging products in the world, all under Rohrer’s ezCombo program,” Rohrer said in a statement.

Rohrer is headquartered in Wadsworth, Ohio. The company was founded in 1973.

Transparent Container’s chairman Dan Greiwe and president Scott Greiwe will be staying with the company as advisory board members.

With this acquisition, the combined Rohrer and Transparent Container organization will be made up of more than 1,000 employees, with 11 manufacturing facilities across North America.

## Thermo-Rig Desktop Vacuum Former Hits Kickstarter

By *Julian Horsey*

October 4, 2018 — The team at Proto-Storm based in Vancouver, have created a new desktop vacuum former specifically designed for makers and to provide professional quality thermoforming in a portable and affordable package. Watch the demonstration video below to learn more about the design of the heating element complete with its digital temperature control system and vacuum system.

Offering a working area of 200mm x 200mm the desktop thermoforming machine has been under development for a number of years and is now ready to take to market. “No longer will you need to cough up \$10K+ for an industrial thermoforming machine or spend hundreds of dollars to wait weeks for your supplier to run your prototype forms. With the Thermo-Rig, if you can dream it, you can make it in a matter of minutes. Start with a clay model, a carving, a 3D print or heck, even a fruit carving from the weird cat lady down the street. Simply plug it in, load it up with your favorite plastic, dial in the temp and go.”

The Proto-Storm desktop vacuum former is now available to back from \$419 or £324 with worldwide shipping expected to take place during January 2019. “Thermoforming at its simplest level is the process of heating special plastic to the point at which it is pliable or in scientific terms: “melty”. Then that special “melty” plastic is stretched over a 3D template where vacuum can be applied to make a high-resolution copy of that template. The end result is a form that can be then used a final product or used as a mold. These molds can then be filled with casting compound for quick and consistent production.”

## rPlanet Earth Opens First of its Kind Closed-Loop PET Plastic Recycling and Packaging Manufacturing Facility

*Los Angeles, California*

October 31, 2018 — rPlanet Earth, a company founded on developing ground-breaking solutions to eliminate plastic waste, has just opened its doors to the world. Located in Vernon, CA, USA, rPlanet Earth’s 302,000 square foot facility is the first of its kind, vertically integrated closed-loop recycling and manufacturing facility capable of producing post-consumer plastic packaging for food, beverage and consumer products. “Depending upon the location, up to 90% of PET bottles are not recycled. With the goal of ‘zero plastic waste on our planet earth’, we created rPlanet Earth, to change that. Our state-of-the-art recycling and manufacturing facility enables us to convert curbside collected PET directly into FDA approved food grade recycled PET (“rPET”) packaging; all while having a significantly lower carbon footprint than traditional PET

packaging manufacturers. There's no other facility of its kind", says Bob Daviduk, Co-Founder and Co-CEO.

Many traditional recycling systems do not produce material suitable for food contact. Most recyclers have not invested in the sophisticated equipment necessary to produce "bottle grade" recycled PET. As a result, most rPET cannot be used in applications that must adhere to the FDA's requirements for direct food contact. rPlanet Earth's proprietary closed-loop process is the first of its kind in which reclaimed PET products from post-consumer curbside collection are turned into those of equal or higher value, all under one roof. The Vernon, CA facility has the capability of processing up to 80,000,000 lbs of PET per year in its first Phase. Phase two, which is already in planning, will enable processing a total of 160,000,000 lbs. or more of PET each year.

At rPlanet Earth, reclaimed material is first subjected to a rigorous multi-step process to ensure PET is separated from other plastic types before it is ground into flakes, cleaned and decontaminated. The complete vertical integration of the plant allows the Company to efficiently process and directly feed rPET resin from the decontamination reactors into extrusion systems to produce our proprietary EnviroPET™ rPET sheet and forming platforms to create new post-consumer rPET thermoformed containers, clamshells, and cups, as well as injection molded preforms for blow molding of rPET bottles. The resulting products not only meet or exceed FDA regulations, but skipping the multiple heating and cooling steps prevents material degradation which results in packaging with better color and clarity versus standard rPET. The result is a revolutionary new rPET material that has comparable material and performance properties of virgin resin.

Furthermore, as sustainability is at the core of rPlanet Earth, the entire system is designed for maximum efficiency. The production of our rPET uses 90% less water per quantity of output and consumes significantly less energy when compared to the production of virgin PET. As a result, rPlanet Earth is the PET packaging manufacturer with the smallest carbon footprint in the world; having a 60% smaller carbon footprint than virgin PET producers and 20% smaller footprint than typical rPET producers.

rPlanet Earth and the goal of "zero plastic waste on our

planet earth" is a direct result of the vision of co-founders Joe Ross and Bob Daviduk. Their concept of turning reclaimed post-consumer PET into products of equal or higher value all under one roof has not gone unnoticed as rPlanet Earth has attracted over \$100,000,000 in investments from a range of entities who all believe in the vision. With plans to build three or more new plants at sites elsewhere in the U.S. and possibly in other countries, rPlanet Earth is dedicated to be the leader in creating a truly sustainable, closed-loop system for the recycling and reuse of post-consumer plastics.

For more information about rPlanet Earth, including Company contact information, visit [www.rplanetearth.com](http://www.rplanetearth.com).

## Placon Growing in Indiana

By *Plastics News*

October 31, 2018 — Placon Corp. is expanding its clean room capacity in Elkhart, Ind., to bolster capacity for medical packaging.

The Madison, Wis.-based company said the move will double its thermoforming capacity at the site. The new clean room, designed to accommodate three thermoforming presses, is expected to begin operations with the installation of the initial press by the end of November, the company said.

John MacDougall, medical sales manager said, in a statement, the additional capacity "supports our corporate strategy for growth in the medical packaging market."

Placon has a total of three medical packaging sites in the Midwest, the company said. Other medical sites are in Madison and Plymouth, Minn.

The company also serves the food and retail markets. Placon ranks 17th on the most recent Plastics News list of North American thermoformers with annual sales of \$150 million.

**NEED FOR HEAT?**



**POLYSCOPE**  
fresh thinking. great products

SMA-based HI-PS solutions designed for sheet extrusion

**High thermal stability • Excellent adhesion towards other layers**

Global HQ Polyscope • Geleen, the Netherlands • T +31 46 75 000 10  
info@polyscope.eu • [www.polyscope.eu](http://www.polyscope.eu)

## Sinclair & Rush Adds MasterPac to VisiPak Division

By Jim Johnson, *Plastics News*

November 5, 2018 – The acquisition of clamshell packaging maker MasterPac Corp. is increasing both thermoforming capacity and capabilities for Sinclair & Rush Inc.

Sinclair & Rush's VisiPak division purchased St. Louis-based MasterPac.

"The acquisition of MasterPac Corp. is aligned with our growth strategy for the VisiPak packaging division and presents us with numerous new business opportunities," Chief Operating Officer Brad Philip of Sinclair & Rush said in a statement.

"This transaction gives us the ability to enter the medical packaging business and strengthens our product offerings in the consumer and industrial packaging markets," he said.

The acquired St. Louis location joins existing locations in

Arnold and Fenton, Mo., Carlstadt, N.J., and Changzhou, China. The company also has two locations in the United Kingdom — Rochester and Maidstone in Kent — and one in Riverstone, Australia, a suburb of Sydney.

VisiPak makes a variety of clear packaging through extrusion, thermoforming and injection molding. Products include clamshells, tubs, boxes, blister packs, trays, containers, jars and vials. Sinclair & Rush also does vinyl dip molding and foam extrusion.

Along with the VisiPak name, Sinclair & Rush also operates as StockCap, which makes caps, plugs, covers, masking products and parts trays. GripWorks makes hand grips. The company is based in Arnold.

MasterPac was started in 1990 and was previously owned by David Lawrence and Mychelle Lawrence, according to that company's website.

Key markets for MasterPac have been automotive, medical, food, marine, hunting, fishing and electronics. Products include clamshells, trays and blisters, the website states. |



**HYTAC®** Innovative Tooling Materials for Thermoforming

**CMT**

US: +1 508 226 3901 | [www.cmtmaterials.com](http://www.cmtmaterials.com) | EU: +31 416 747 016

Great Plugs = Great Parts



**WHAT DOES TPO NEED?**

- UNIFORMITY**
- CONTROL**
- REPEATABILITY**

Retrofit Today with Solar Products **ELECTRIC INFRARED** heaters.

Custom heater technology – from America's largest supplier of infrared heaters.

**Call 1-800-616-2601**

For complete information visit our website at [www.solarproducts.com](http://www.solarproducts.com)





# ANTEC® 2019

Detroit, MI • March 18-21, 2019  
CO-HOSTED BY SPE DETROIT

## THE CONFERENCE FOR PLASTICS PROFESSIONALS

REGISTRATION IS  
**OPEN**

### New this year!

ANTEC® has been reformatted into two programs, INSPIRE and INSIGHT, to best represent the ideas and trends shaping our plastics industry.

#### ANTEC® 2019 INSPIRE

550+ technical and business papers and 60+ marketing presentations, spanning Monday thru midday Wednesday, you will be able to enjoy the traditional ANTEC® that you know and love – complete with networking, student events and exhibitor receptions.

#### ANTEC® 2019 INSIGHT

Running from Wednesday midday and all-day Thursday with megatrend sessions on Packaging, Building & Construction, Sustainability and Transportation you will get face-to-face interaction with expert representatives from the largest industry segments. INSIGHT will focus on the big picture –and the biggest questions being asked in the plastics community today.



[www.4spe.org/antec](http://www.4spe.org/antec)

## Industrial Design Students from Georgia Tech Compete in SPE Radio Controlled Car Race & Design Competition

By Ryan Fuller & Karina Patricia



Last year, Georgia Tech Industrial Design students were granted the opportunity to compete in the 2018 SPE Thermoforming RC Car Competition which took place in Fort Worth, Texas. The RC car design competition involved designing, thermoforming, decorating, and racing a 1/10th scale RC car body or "shell". Among the group of five students, our team, comprising of Ryan Fuller and Karina Patricia, stepped up as one of three Georgia Tech teams.

After Robert Browning (who eventually became our sponsor) came to our school as guest lecturer in late 2017, we were inspired by the opportunity to gain design experience in a field that was not usually taught or emphasized in the standard ID curriculum. We decided that this RC car design competition would be a rewarding experience and so we moved forward with designing our car.

Over the summer, upon receiving the RC car from Robert, we both began ideating and developing concepts using the Fusion 360 CAD software. Our ideas ranged from making a sleek, shorter version of existing cars to an oversized low-rider. Taking advantage of the Fusion 360 shared folder, we compared and contrasted our preliminary CAD models. Using Karina's sketches and Ryan's design ideas, we managed to refine our 3D models and settle on three refined concepts. Robert provided us with valuable feedback on thermoforming constraints such as draft angles which aided us in making the final edits.

Our final design, inspired by the Bugatti Veyron, would utilize similar paint schemes and features of the original car.

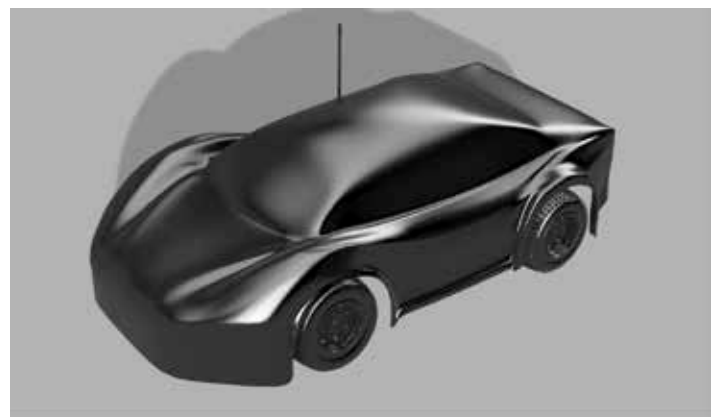
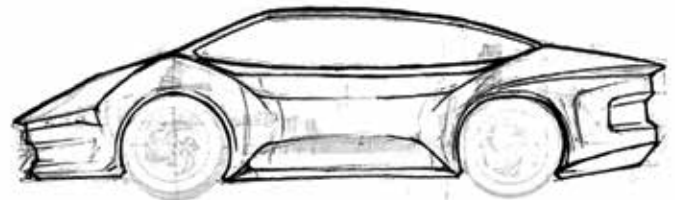

# SIEMENS

*Ingenuity for life*



Precise, space-saving, and efficient heat control increases reliability and efficiency.

SIPLUS Heating Control System (HCS)

**Key benefits:**

- Seamless integration into the automation architecture
- Integrated diagnostic functions
- UL certified controllers
- Space savings of up to 85% in the control cabinet
- Reductions of up to 80% in cabling work
- Significant cost savings
- Energy efficiency

©2016 Siemens Industry, Inc.

[siemens.com/siplus-hcs](http://siemens.com/siplus-hcs)

After deciding on a design, our team acquired a CNC cut mold of the design for thermoforming, and formed three plastic models using the thermoforming machine in our Industrial Design Studio. Then came the time to decorate and perfect our best model. We decided that adding LED lights while also following Robert's suggestion of using a rear spoiler would really make the design stand out.

Finally, after painting and decorating our model, it was time to compete in Fort Worth, Texas. Our design led our team to win both the best design award and the people's choice award. In addition, Ryan's driving led the team to win the racing bracket. We'd like to dearly thank Robert Browning as well as all of our sponsors for their assistance in our achievement. |

SPE Radio Controlled Car  
Race & Design Competition  
Proudly Sponsored By:



## The PlastiVan Visits Fort Worth

By Lesley Kyle, CMP

Students from two local schools stopped by this year's SPE Thermoforming Conference to roam the exhibit hall aisles of the Fort Worth Convention Center and to learn about thermoforming and plastics. Thirty-eight students from Grand Prairie ISD and 40 students from DeSoto ISD and their chaperones participated in this year's school visit program.

The students took part in educational sessions that were led by PlastiVan Educator, John Paul Dingens, on the exhibit hall floor. Hands-on activities engaged the students and piqued their interest in future opportunities in the plastics industry. The students and their chaperones then toured the show floor, met with exhibitors, and enjoyed lunch courtesy of the SPE Thermoforming Division. One student from Desoto ISD also participated in the first annual SPE Student RC Car Race and Competition.



Education is of paramount importance to the Thermoforming Division, and the PlastiVan program has been an annual fixture during the Conference for many years. The curriculum for each PlastiVan program is tailored to each school's needs, and programs are also available for grade school and middle school classes.

"Thank you again for your inclusion and support in the SPE Thermoforming Division's 2018 Student RC Car Race," said Danielle Moore of Desoto ISD, who organized the school

Thermoforming systems  
Packaging systems  
Molds systems



**Therformance**  
*Performance in Thermoforming*

**illig**<sup>®</sup>



**IML-T<sup>®</sup>** *Setting standards!*



**RV 74** *TF made easy!*



**RDM 75K** *Simply the best!*



**Complete turnkey solutions with superior performance!**

ILLIG Maschinenbau GmbH & Co KG  
Headquarters, Germany  
[www.illig.de](http://www.illig.de)

ILLIG USA  
In North America call toll-free  
1-855-824 00 04, [mail@illigusa.com](mailto:mail@illigusa.com)



district's visit. "The high school team had an invaluable learning experience and has already begun brainstorming modifications and possibilities for future enhancements. Your support and sponsorship have been pivotal in increasing awareness and interest in plastics engineering in Desoto ISD."

The PlastiVan program and its staff of professional educators travel around the U.S. to teach the next generation about the value of and opportunities in plastics. Corporate sponsors are sought to underwrite the expenses associated with these school visits. To learn more about bringing the PlastiVan program to a school near you or to sponsor a local school visit, contact Julie Proctor, PlastiVan Program Coordinator, at [jproctor@4spe.org](mailto:jproctor@4spe.org), or visit the website at [www.4spe.org/plastivan/](http://www.4spe.org/plastivan/).



## SENOPLAST

**Quality. Innovation.  
Environmental consciousness.**

Senoplast - globally successful with innovative and high quality plastic sheets and films.

Thermoformed **senosan**® products are used in various industries and applications - such as in the automotive, sanitary and furniture industries as well as for suitcases, roofboxes and refrigerators.

[www.senoplast.com](http://www.senoplast.com)

## Why Join?

**It has never been more important to be a member of your professional society than now, in the current climate of change and global growth in the plastics industry. Now, more than ever, the information you access and the personal networks you create can and will directly impact your future and your career.**

**Active membership in SPE – keeps you current, keeps you informed, and keeps you connected.**

**The question really isn't  
"why join?" but ...**

## Why Not?

# A NEW GENERATION 125 TON THERMOFORMER FOR SOLID SHEET

**The Model 45** doesn't require a 3rd motion or airbox. A smart SASH (Servo Adjust Shut Height) monitors an accurate measuring system to maintain the newly designed platens at  $\pm .002$ " flatness.

- Air cylinders operate the sheet clamp frame.
- The bottom platen drives the plugs.
- **Option: can be ordered 52" wide.**
- Max. product depth 5"
- Shut height 30"
- Sheet width 48"
- Sheet line 53.5"

- More Power
- Less Air
- Faster Cycle
- Less Cost



Phone: (509)248-0194  
www.irwinresearch.com  
sales@irwinresearch.com

 **IRWIN**  
Research & Development



## SPE PLASTIVAN™ PROGRAM

### ● SPE PLASTIVAN™ SPONSORSHIP

With a national focus on STEM disciplines at all educational levels, both private and public resources are being marshalled to address a shortage of skilled employees across manufacturing industries. It is critical for plastics and related companies to be active in their communities, both to demonstrate career opportunities and to promote the benefits of plastics which are often misunderstood.

The PlastiVan™ Program is a great way to excite young people about the science and the vast opportunities the plastics industry has to offer. The program travels to schools and companies throughout North America, educating middle- and high-school students about plastics chemistry, history, processing, manufacturing, sustainability and applications. Corporate sponsors have a unique role to play in this community outreach program, linking the wonders of plastics to applications and jobs in the real world.

### ● COSTS OF SPONSORSHIP

The fee for the PlastiVan™ program is \$1500 a day. Your sponsorship covers travel & expenses for educators as well as all materials. SPE coordinates all scheduling and communication with schools. This allows more students greater access to the wonders of plastics in their own communities. Sponsorship of the PlastiVan™ Outreach Education Program is a tax-deductible donation.



### ● BENEFITS OF SPONSORSHIP

As part of the sponsorship package, companies gain access to students, parents and educators in local communities. Sponsoring companies can choose to provide a list of local schools or SPE staff can work with you to select schools and arrange schedules. Many companies choose to send a representative to speak directly to the audience about products and career opportunities. In addition, SPE can help coordinate PR with local press to craft stories about the PlastiVan™ visit. These stories are then added to SPE's library of testimonials highlighting the success of the PlastiVan™ program.

## BECOME A SPONSOR TODAY!

For more information or to schedule a school visit, contact:

**Deb Zaengle**

PH: +1 203.740-5417  
dzaengle@4spe.org







# WHEN PRECISION TAKES FORM

For optimal thermoforming and perfect end products.



STEEL RULE DIE



CUP FORMING / TRIM-IN-PLACE



VACUUM FORMING

- Up to 5 % less material use
- Up to 50% reduction in start-up waste and time
- Amortisation time of less than 6 months
- Save thousands of wasted units
- Stable production process

 **TOOLVISION**<sup>®</sup>  
MEASUREMENT ENGINEERING FOR THERMOFORMING TOOLS

Adelmannstr. 17  
D-86441 Zusmarshausen  
Germany

Tel. +49 8291-8583330  
info@toolvision.de  
www.toolvision.de

# 2018 Thermoforming Conference Review

By Bill Bregar, *Plastics News*  
Edited by Conor Carlin

"Hunting Unicorns" was the title of a panel discussion on finding young employees that kicked off the SPE Thermoforming Conference.

That says it all. Just like the rest of the manufacturing sector, thermoformers are scrambling to attract young people in the face of low unemployment and the lingering perception by many that manufacturing is not a good career choice.

Thermoforming company officials are saying the situation is getting even more difficult, said Dan Sproles, who runs Sproles Business Consulting LLC in South Bend, IN.

"Probably in the last year or so, [they are saying], 'I just need a warm body,'" he said.

Monica Jacobs, an executive recruiter for rigid plastic packaging with the Cincinnati-based executive search firm KLA Industries Inc., said low unemployment means prospective employees are getting multiple job offers.

"Companies really have to sell themselves," she said. "You want every candidate to leave that interview wanting to come work for you. Of course, you make the final decision."

Jacobs said investing in automation can pay back two ways: by replacing employees in positions prone to high turnover, like pickers and stackers, and by attracting young people to thermoforming.

"It gives you a way to embrace the next generation," she said.

Sproles said the basic interview process has to change when trying to hire young people. Companies are not going to find candidates experienced in thermoforming, so they have to pay attention to other signals such as body language. Many of them have not worked in a factory before, so it can be intimidating. That makes the

onboarding process very important.

"Once you get to work, you have to train, you have to explain, you have to help them," Sproles said. "Thank them. Know their names. Show some appreciation."

Sharon Haverlak, Vice President of People and Culture of sheet extruder Sekisui SPI in Bloomsburg, PA, agreed that introducing a new younger employee to a manufacturing company takes attention to detail.

"Onboarding is about consistency to explain the company's vision and culture," Haverlak said. "You have a much better chance of retaining an employee if you do a good, thorough job of onboarding."

Haverlak said when Sekisui hires someone off the street, the company takes two weeks to train them in the "hard skills" of the factory job. "When we're looking for our shop floor, we want to find people with good soft skills like communication and teamwork," she said.

Bloomberg is near the Pennsylvania College of Technology in Williamsport, PA, and its thermoforming center. The Sekisui SPI sponsors scholarships and sends employees for training, she said.

The panel was moderated by Conor Carlin, Sales and Marketing Manager at Attleboro, MA-based plug-assist maker CMT Materials Inc. There are unforeseen issues, he said. One is wage stratification. Say a company hires young programmers and pays them well. Older machine operators could resent that.

Haverlak encouraged thermoformers to sponsor the PlastiVan™ to visit local schools. Bringing high school teachers and guidance counselors into a factory is also a good idea.

"The conversations are very important" she said.

Sekisui also brings retirees back and mentor younger employees.

Two Texas school groups toured the trade show floor at the Thermoforming Conference. Nathan Troutman, Senior Manufacturing Engineer at Precision Formed Plastics Inc. in Irving, TX, said sponsoring field trips and local STEM

education programs is a good idea.

Sproles said a key is to get the attention and interest of young workers, then do mentoring.

"The biggest problem is work ethic," Sproles said. "It's hard to find people with good work ethic."

### **A Millennial Speaks**

Later in the conference, keynote speaker Ryan Avery, himself a millennial, described how to recruit, retain and motivate millennials. The motivational speaker co-founded AveryToday Inc. in Englewood, CO.

Many thermoforming people in the audience were baby boomers. Avery said people have to understand how different generations raised their kids. Boomers grew up in a triangular, hierarchical family, with their mom and dad at the top of the pyramid.

"You were at the bottom of that pyramid. And you saw that if you worked hard and learned, you would be at top," he said.

Avery said that defined life worked for the boomers. "Baby boomers know what it is to work hard," he said. "You are the definition of hard work." Boomers paid for their car and even their own college.

Then, when the boomers became parents, what did they do? Instead of a triangle, family life was more circular, he said.

"We sat at the same table that our parents sat, and you talked to us," Avery said, getting laughs from the audience. "Parents asked their kids for advice. How do you run this computer, this smartphone?"

"So we were in a community since day one," he said.

Instead of being told to clean their rooms right now, as the boomer would have heard as a child, Avery said, "We were the generation of 'do-it-whenever.' 'Make sure your room is clean before my friends come over.'"

Avery said companies need to be more circular to reflect this upbringing.

"Whatever happens inside our family unit is how we perceive and do things in our professional lives as well," he said.

He joked that a millennial will go into a top executive's office and ask, "How's it going?"

Millennials, he said, might want to come in late, work, run some errands at lunch, and then work from home in the evening. That's a big change.

"Baby boomers, you had a work-life balance. You shut your computer off at 5 o'clock and you went home and did your own thing," he said.

Also, Avery noted that baby boomers were hired for their great resume, knowledge and experience. What you know. But now you can Google anything. So the key answer from prospective millennial employees is, "I will."

"The next time you hire somebody and they have a great resume, keep in mind the 'I will' as well," Avery said.

### **Off to the Races**

Instead of the usual student-designed parts on the parts competition, this year's conference pitted students racing radio-controlled cars on the final day. Companies sponsored the students, who got a standard chassis, then students had to design the shells and thermoform them. The SPE thermoforming division handed out trophies and cash prizes to the best design and the race winner, as well.

Mark Strachan, President of Global Thermoform Training, Inc. and past president of the SPE Thermoforming Division, conceived the idea, designed and built the track, and put it together in Fort Worth.

"Basically, I was thinking about how to get the students excited? When they come here, how do we involve them? How do we engage them? And how we get more schools to come? And how do we get the companies involved?" Strachan said.

"The student design competition was getting stale. It was static and there was no real excitement generated," he said. "And so now you have the various companies that are engaged with the schools, engaged with the student. And now this is creating some excitement. The colleges all want to come in and race," he said. |

## 2018 Thermoforming Parts Competition

By Bill Bregar, *Plastics News*  
Edited by Conor Carlin

Fort Worth, TX, September 24-26

Profile Plastics Inc. won the People's Choice Award and a gold award for heavy-gauge pressure forming in the Parts Competition at the Society of Plastics Engineers' Thermoforming Conference. Placon Corp. also picked up two awards at the conference. The winners were recognized at an awards dinner at AT&T Stadium, home of the Dallas Cowboys.

Profile Plastics won both awards for a medical cart enclosure used in surgical procedures. The cart has 10 pressure formed enclosure parts: seven for the primary cart, and three for a secondary cart.

"They can be used independently, or they can be attached," said Mike Diaz, technical sales manager at Profile Plastics.

The enclosure parts are formed from polycarbonate-ABS to meet stringent requirements for rigidity, chemical and temperature resistance, and a highly-cosmetic appearance. The customer required the parts with zero or minimal mechanical attachment.

"It is driven by end-customer parameters," Diaz said. "From a customer standpoint, they don't want to see a lot of fasteners. For medical parts, you have cleaning concerns."

Profile Plastics molded in many of the attachment features. The final design incorporated numerous movements in each tool to provide the fastening features, plus the cosmetic finished seams. Ramesh Mehta, Profile's Design and Project Engineering Manager, said the parts are all interlocked, with minimal fasteners.

According to the company, numerous challenges came from the interaction between the rear top cover and the side covers to achieve a hidden fastening system while maintaining cosmetic alignment between the parts. The

thermoformer used complex core pulls on the upper cover to incorporate slots for a work surface table.

"This is a very complex tool with deep draws," Mehta said.

The large front cover of the secondary cart presented a challenge with using four-way undercuts due to the extreme depth of draw. The final design allowed for the elimination of additional side panels and reduced overall tooling cost, Profile officials said. Diaz said all parties had to work closely together to make a finished product that met both strict customer requirements and economical manufacturing concerns.

"The key to the whole project establishing a collaborative effort among several partners, including our customer's customer as well," he said.

### Heavy-Gauge Pressure Forming, Silver



Ray Products of Ontario, CA, won the silver award for a medical device cover. The customer was ready to move to mid-scale production based on a prototype that used urethane casting to create the panels for the enclosures. But that process, and its soft silicone molds, meant limited manufacturing capacity, high part cost, and issues with part-to-part consistency, according to Ray Products officials.

Enter pressure forming. By switching from urethane casting to pressure forming, the medical device manufacturer could significantly lower costs, improve manufacturing speed, increase durability and guarantee repeatability — while planning for future increases in demand and production capacity.

A design firm worked closely with Ray Products' manufacturing team and the device maker's engineers.



### **LOW FLEX™ FORMER SERIES**

- *LF5.0 Shown – 190 Ton*
- *Numerous quick change features*
- *Easy maintenance access*

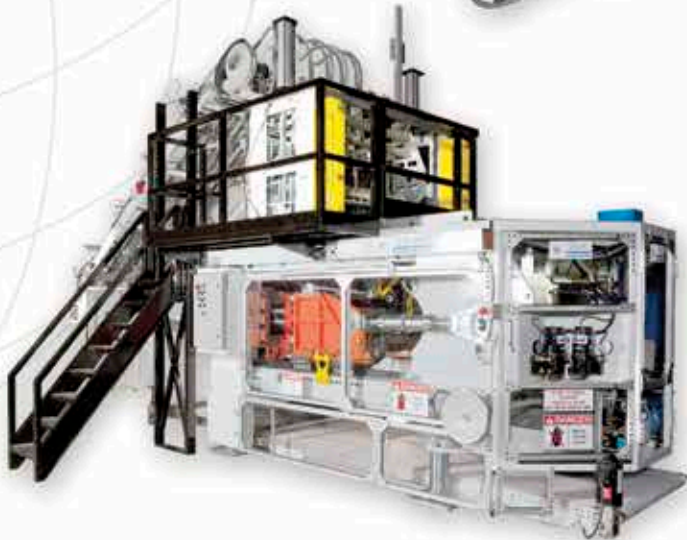

### **LINEAR RAIL TRIM PRESS**

- *LR5 Shown - 45 Ton*
- *Side Loading of Tool*
- *Numerous quick change features*
- *Precise tolerances via linear rails*

### **TECHNOLOGY**

*Flat Bed Formers  
Form-Trim Models  
Linear Trim Presses  
Linear Vertical Press  
Heavy Duty Presses  
Tilt Bed (IML)  
Linear Pre-Punch  
Linear Scoring Station  
Rotary Drum Former*

### **PROCESSES**

*- PP, PET, HIPS, OPS  
- PLA, HDPE, PS Foam  
- In line/Roll Fed  
- Cups, Car Cups, Lids  
- Retort Products  
- Tamper Evident  
- Hinged Trays  
- Storage containers  
-TIML*

### **VALUE**

*- Energy Efficient  
- Production Rates  
- Move Times  
- Ease of Access  
- Reliability*

### **SERVICE**

*- Training Classes  
- On line help  
- Process Training  
- After hours help  
- Included start up service*



**Thermoforming Systems LLC**

1601 W. Pine Street, Union Gap, WA 98903-9502 • 509 454 4578 • Fax 509 454 4598

[www.tslusa.biz](http://www.tslusa.biz)

The groups reduced the total number of bosses, designing undercut features for rigidity and improved fit, and adding other attachment points to lower the total manufacturing and assembly costs, and to improve aesthetics.

Ray Products used machined aluminum tooling that is temperature-controlled with actuating slides. Starting with good tooling achieves consistent parts, important for using six-axis robotic trimming to finish the part.

## Heavy-Gauge Vacuum Forming, Gold



The top vacuum forming award went to Fiber Pad Inc. of Tulsa, OK, for a shroud cover for the driver and passenger consoles on a bass fishing boat. The part also provides a surface to mount a windshield.

Fiber Pad vacuum forms the shroud body using a custom-built machine that uses a "wrapping" method, which the company said provides larger undercuts that normally would be permitted with standard vacuum forming machines. This method also maintains a more consistent material thickness across the overall part. The part is trimmed on a five-axis CNC router.

The material is an ABS sheet with a decorative laminate that gives resistance to ultraviolet light while providing texture. Because of the difficult geometry, Fiber Pad officials said that this type of shroud has typically been made using glass-fiber reinforced composites. The customer identified this part as a candidate for plastic replacement to reduce the boat's weight and to lower the carbon footprint.

Fiber Pad molds the part on cast aluminum tooling with water lines for temperature control. Closely controlling mold temperature was key to reducing and removing chill marks.

## Heavy-Gauge Twin Sheet, Gold



Therma-Hexx Corp. of Portsmouth, NH, grabbed the top twin-sheet award for its ThermoPANEL, a modular heat transfer system for heating and cooling exterior and interior surfaces. Its primary applications are efficient snow melting of pavements and collecting solar energy to heat swimming pools, while also cooling the pool patio at the same time.

ThermoPANELS are twin-sheet thermoformed using polyethylene on a shuttle-type former with molds that allow for the creation of a multi-channel panel with stanchions and inlets that allow for even, turbulent flow of the hydronic fluid throughout the modular panel. The result is an enhanced, conductive or radiant, heat transfer between the panel and any surface it's in contact with, according to Therma-Hexx.

Temperature-controlled tooling forms an inlet and an outlet near the center of each panel, which allows for the secondary process of the socket-fusion of half-inch, PE-RT "S" shaped tubes between the panels. These tubes create foldable rows of pre-assembled panels up to 50 feet long.

After forming, the panels are cooled to a specific temperature, allowing for a predetermined amount of shrink, then they are trimmed on a 30-ton stamping press with a 3D die. The design of the cutting die was critical for trimming around the inlets while allowing for a variance in size because of the shrink.

Therma-Hexx officials said an automatic loading double-end thermoformer is being built to reduce cycle time by more than 60%.

### Heavy-Gauge Twin Sheet, Silver



If you have bears getting into your trash, you need the bear-resistant lid for a roll-out cart, molded by Allied Plastics Inc. of Twin Lakes, WI. The lid even has a molded-in bear head.

Existing cart lids were thermoformed from a single sheet and then reinforced with a metal angle or brackets and rivets — no match for a hungry bear, Allied said.

By using the twin-sheet process, the design team could make a much stronger lid, but one that also has some flex when the bear would try to get into the cart. The lid then immediately returns to back to its formed state, keeping the bear out.

Allied Plastics forms the lid from high molecular weight PE sheet. The tool is a cavity water-cooled, cast oversized, machined aluminum mold with a chemically etched surface.

And yes, the lid and cart are tested using actual bears. In fact, Allied Plastics said the cart and lid have passed the Interagency Grizzly Bear Committee, along with other certifications.

### Roll-Fed Consumer, Gold



Placon of Madison, WI, won for its trays in a box to hold the Pokémon Premium Trainers XY Collection. The package is intended for retail use, but it also converts to a storage box for players.

The plastic clamshell in the cover allows for high-level promotional cards to be displayed in the front of the box. The window also lets consumers get a peek at additional cards in the box.

A magnetic closure on the front panel helps keep the outer box closed and protects the product.

The trading card game package includes a rigid setup box with printed foil paper wrap and three recycled PET thermoformed trays inside made from Placon's EcoStar material.

The package design reduced material thickness, so multiple thermoformed trays could be stacked together in one box. Pokémon passed along the cost savings to the consumer, allowing a \$20 reduction in the manufacturer's suggested retail price.

Follow the SPE Thermoforming Division on Twitter!



@SPEThermo

## Roll-Fed Innovation, Gold



Anyone who has ever been to an industry conference will appreciate the nametag tray, one that netted Placon the gold in this category.

Placon's customer requested a thermoformed tray that would hold name tags in several shapes and organize and display them for large meeting registrations. Placon designed a thermoformed tray from EcoStar recycled PET.

The dual-purpose snap-fit closures connect two trays together to hold 100 name cards, twice the number of the existing product. You can unsnap the closures to separate the two trays and get setups for two registration lines, arranged by alphabetic order.

Placon officials said the perforation allows the tray to fold into a square, and the snap-fit closure locks the square shape firmly for safe storage and easy transit.

## Quarterly Deadlines for 2019 Copy and Sponsorships

### ALL FINAL COPY FOR EDITORIAL APPROVAL

**FEB 15** Spring

**MAY 15** Summer

**AUG 01** Fall

**NOV 15** Winter

*Conference Edition*

*Post-Conference Edition*

*All artwork to be sent in .eps or .jpg format with minimum 300dpi resolution.*

## Roll-Fed Innovation, Silver



CMI Plastics Inc. of Ayden, NC, won for a tray used in a point-of-purchase display for a Knob Creek Old Fashioned Cocktail Kit, which includes a fifth of Knob Creek bourbon, a bottle of bitters, a box of sugar cubes and muddler (a bar tool used to mix cocktail ingredients).

The customer's proposed tray design was to have a rigid thermoformed tray from high-impact polystyrene with a printed paperboard mask applied. The new design eliminates the need for paperboard and gives a realistic wood grain appearance of barrel slats used for whisky.

CMI Plastics formed the tray from coextruded ABS, which gives better structural properties over the proposed HIPS design, the company said. 60% of the package is recycled utility black and 40% is color-matched brown. The mix was carefully engineered with a natural gradient of black and brown colors, giving the tray a weathered look, and giving each tray a slightly different appearance. The wood grain was reverse engineered from natural wood grain to pattern the surface. Master patterns were sculpted and sampled to give the proper look and manufacturability using cast aluminum molds.

For the mold, designing and forming proper undercuts posed the biggest challenge. The manufacturing posed challenges because of the draw ratio, stress whitening, material distribution and color consistency, according to CMI.



## Roll-Fed Food, Gold



Global Plastics Inc. of Perris, CA, cracked open the top prize in the food category with an egg carton pformed from 100% recycled PET.

According to Global Plastics, other current PET egg cartons fall short as a substitute for foamed polystyrene because they don't efficiently flow through the common automation equipment in the filling lines. But egg farmers helped design this carton, the company said. The clamshell, hook-locking package is formed from recycled PET sheet rolls. The package is offered in clear PET and green PET, with amber coming soon. A unique aspect is the container was designed to stamp the label on the inside of the package, in-house at the farm. That lets an egg producer use the same package for all of its customers, reducing costly inventory.

And shoppers no longer have to open and check the eggs to see if any are broken, since the thermoformed egg cartons are translucent. |



We Deliver Parts... Under Pressure™

847.604.5100  
www.thermoform.com

CUSTOM HEAVY GAUGE THERMOFORMING  
PRESSURE • VACUUM • TWIN SHEET • ASSEMBLY

## Your One Stop Thermoforming Partner



### Thermoforming Molds

- Heavy- or thin-gauge, twin-sheet
- Pressure form
- Vacuum form

### Accessories

- Segen Quick-Change
- Sheet Clamps & Silicone Cord
- Plug-Assist Materials & More



TOOLINGTECH GROUP

937-295-3672  
toolingtechgroup.com

## Did you know

the SPE Foundation offers numerous scholarships to students who have demonstrated or expressed an interest in the plastics industry?

**MAAC**  
THERMOFORMING MACHINERY

ROTARY ~ SINGLE STATION ~ DOUBLE ENDER ~ SHUTTLE  
TWIN SHEET ~ PRESSURE FORMING ~ CUSTOM MACHINES

TEL: 630.665.1700 EMAIL: SALES@MAACSALES.COM  
WWW.MAACMACHINERY.COM



Attendees take a break from the exhibit floor to listen to the keynote speakers.



Student teams review their cars before the big race.

Mark Strachan of Global Thermoform Training, Inc. leads the Thin-Gauge Workshop on Day 1 of the conference.



“Hunting Unicorns” was the title of the workforce development session. From L to R: Nathan Troutman (Precision Plastics), Dan Sproles (Sproles Consulting), Sharon Haverlak (Sekisui SPI), Monica Jacobs (KLA), and Conor Carlin (CMT Materials, moderator).



Don Hylton and Robert Browning lead the Heavy-Gauge Workshop to a full house on Day 1 of the conference.



Since 1965, our mission:

The design and manufacture of the most advanced and energy efficient thermoforming machines in the world, for the processing of thermoplastic materials.

O.M.G. srl currently offers a wide variety of standard series machines for both thin and heavy gauge applications, as well as highly customized complete packaging lines, and custom thermoforming systems.

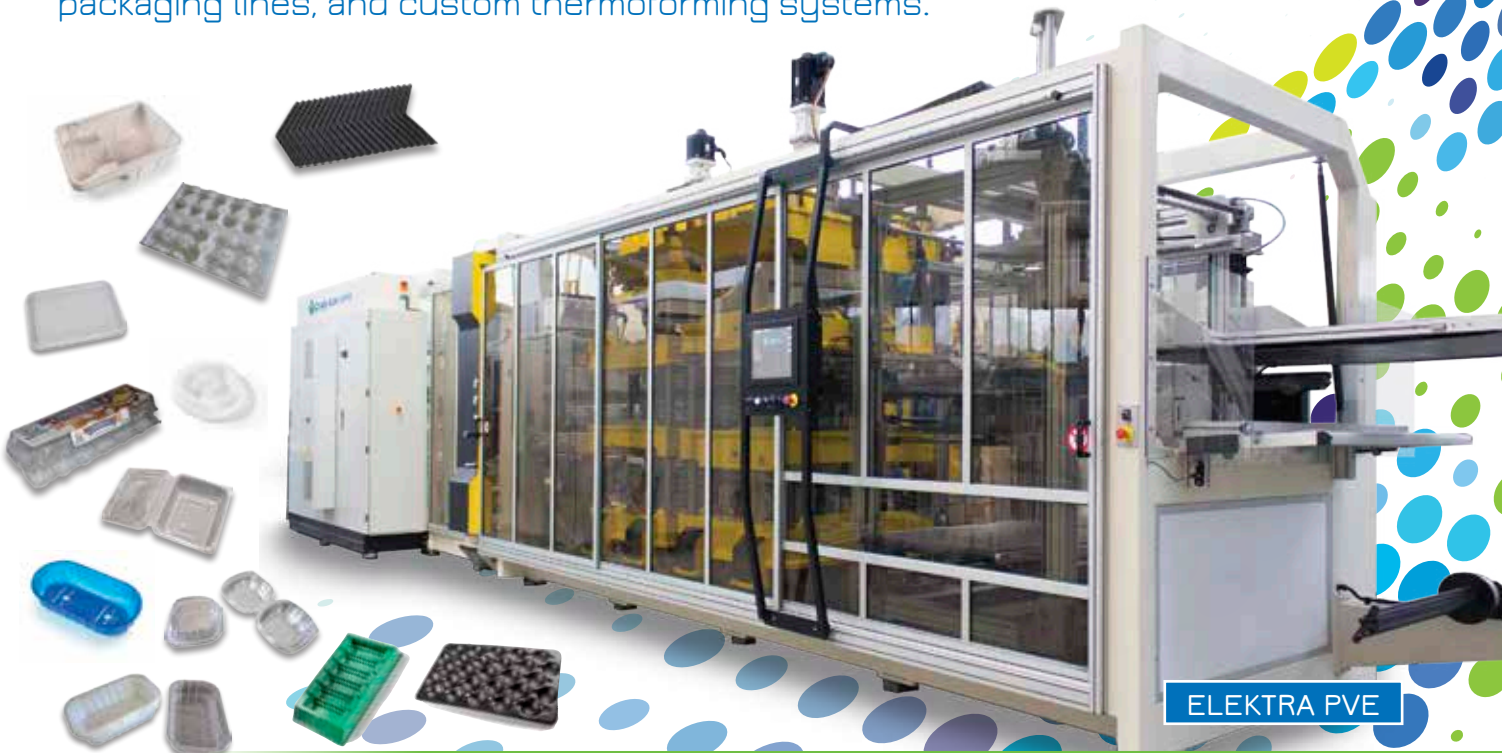

ELEKTRA PVE

## ENERGY EFFICIENT, ALL ELECTRIC SERVO DRIVE MOVEMENTS

From large to small size inline machines, Cut-in-place machines, to custom thermoforming lines and systems for the processing of all types of thermoformable plastics, including PET, PLA, PS, PP, EVOH, OPS, HIPS, EPS, PE, PVC, PC, PE, HDPE and many more...

**O.M.G. can provide a cost effective solution for your everyday challenges!!**

### OPTIONS:

Edge preheater system, drum pre-heaters for running PP, material grinders, cut-in-place presses, punch & die presses, additional modules for after the press automation, single or double sided A/B stacking robots, complete tooling packages and much more...

**Call O.M.G. for all your thermoforming application needs!!**

Italian  
Experience &  
Technology  
in the world



**O.M.G. srl - ITALY**  
10040 Givoletto (To)  
Tel. +39 (011) 9947156  
info@omgitaly.com

**O.M.G. USA**  
Paxton, Ma 01612  
Tel. +1 (508) 7521457  
pietro.caiani@omgusa.net

**O.M.G.: your next thermoforming machine!**

**WWW.OMGITALY.COM**

## Toolvision GmbH Develops Technology to Optimize the Thermoforming Process

*Individual sensor package documents the production process*

Toolvision GmbH, headquartered in Zusmarshausen / Swabia, develops modern measuring technology that is adapted to the requirements of thermoforming. All phases of the production processes can now be monitored, documented and illustrated as a graphic thanks to software. The ToolVision® sensor package, which is integrated into the respective thermoformer and adapted to the tool, provides a graphic visualization of all relevant parameters throughout the entire thermoforming process. The advantages are clear to see: unit costs are reduced, rejects are avoided, tools are protected and preserved, and start-up times are faster, all of which saves time and money.

### **Optimum Quality Assurance for Food and Pharmaceutical Industries**

Manufacturers of food and pharmaceutical packaging constantly need to tackle new challenges. Thanks to increasing automation of processing and packaging, safety and quality demands are also increasing. The food and pharmaceutical industries require traceability and complete documentation of quality controls during the entire thermoforming process and packaging of final products. Further important factors in this case are speed and efficiency. "Up to now, thermoforming process data was not well-recorded and represented a significant problem. Packaging production data primarily depended on the machines' default settings and the expertise of the factory personnel", said Peter Schöberl, Managing Director of Toolvision GmbH. ToolVision measurement technology now allows for real-time process control. Fluctuations in quality and process characteristics during the production of packaging can be a thing of the past.

### **Exact Depiction of the Thermoforming Process**

The ToolVision system consists of up to twelve sensors that are directly integrated into the tool or the machine and are individually adapted to the respective requirements. Up to 125 individual pieces of measurement data are generated

per measurement channel each second, all of which are analyzed in real time. This entails a precise infrared camera visualizing and controlling the temperature of the tools and plastic sheet and transmitting a warning notification to the system in the event of the slightest deviation during the thermoforming process. The monitoring is carried out using envelope curves, which are either placed on the process curves as a quality window, or with the aid of the hotspots from the infrared camera. If the quality window is breached, the corresponding reaction can be instigated in real time. Colored reference graphs illustrate similar tasks: they provide a visual depiction of the target and actual curves in direct comparison. When the results are then implemented in the thermoforming process, it can significantly accelerate the start-up of the machine.

### **Three-stage Error Reporting System Guarantees Comprehensive Controls**

Toolvision GmbH puts its faith in a three-stage error reporting system with its measurement technology. The software makes it possible to draft a shift report detailing a self-defined period during the ongoing production process. The reports can be shared by email. The machines can also be stopped automatically in the event of an error notification. "Defective products are rejected and removed on time thanks to our system, which means that damage to tools and machines can be avoided. Service intervals and repair work can be surveyed and calculated better. We also offer our customers training seminars and workshops on-site", said Schöberl. ToolVision measurement technology is constantly being expanded with additional features. "We will be integrating trend visualization into the system this year, and this will allow our customers to monitor their thermoforming processes and improve them on an ongoing basis."

### **Ready for Industry 4.0**

Automation technology that is relevant for Industry 4.0 is equipped with intelligent and digitally networked measurement-technology processes. ToolVision fits this definition. It supports people in their increasingly complex work processes involving machinery, plant systems, production, processing, logistics and employees communicating with each other. This interconnection means that not only are individual production steps optimized, but the entire value chain.

### About Toolvision GmbH

Toolvision GmbH was founded under the name Schöberl Messtechnik in Dinkelscherben and has been headquartered in Zusmarshausen since 2004. The company began as a manufacturer and supplier of special measuring technologies for the American thermoforming industry. In the meantime, however, the company focused on the further development of systems for the European market—especially for companies in the food and pharmaceutical branches.

You can find further information on the company at [www.toolvision.de](http://www.toolvision.de).

#### Contact information:

Toolvision GmbH  
Adelmannstraße 17  
D-86441 Zusmarshausen  
Germany  
Tel.: +49 (0)8291 / 858 333 0  
Fax: +49 (0)8291 / 858 333 9  
E-mail: [info@toolvision.de](mailto:info@toolvision.de)  
[www.toolvision.de](http://www.toolvision.de)

### Process Optimization: cup forming

Cycle time can be improved by simply changing the start time of the forming air (see the graphs in the picture). Cycle time is improved by 96 ms from 2300 ms cycle time before optimization to 2204 ms cycle time after optimization. |

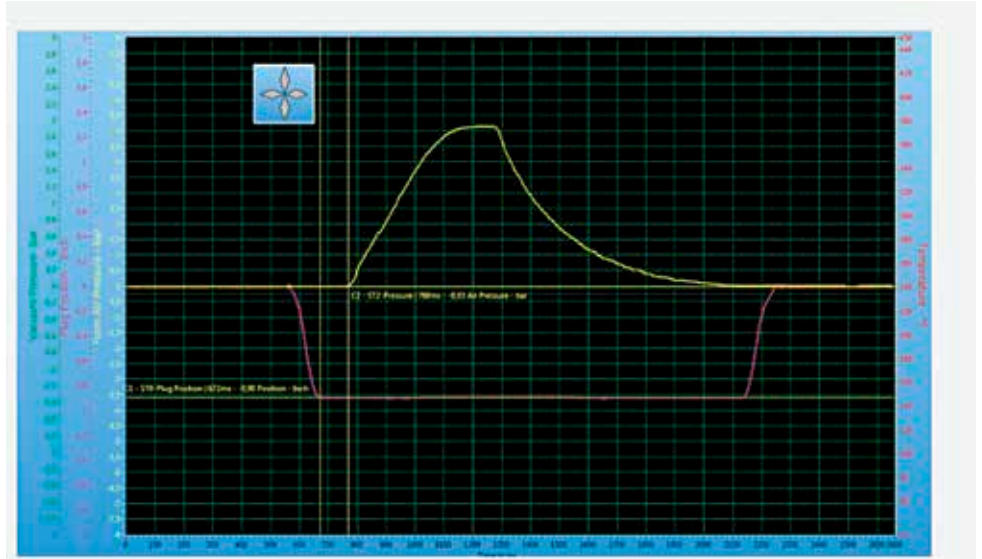

Thanks to visualization by process graphs, this acceleration of the cycle time is now clearly evident.



With a precise infrared camera, the temperature on the tool and film can now be visualized and monitored.

The Toolvision measuring system allows “a look inside” and an exact representation of the entire thermoforming process is possible for the first time. The system, which is adapted to the machine, comprises up to twelve sensors, which are integrated directly into the tool or into the machine.

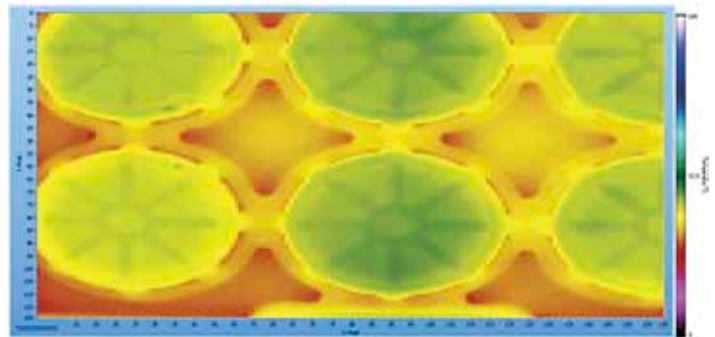

The integrated infrared camera detects even the most extreme temperature deviations and transmits an error message to the system immediately. Above, one can see the image mode. The picture below shows a cavity layout in the scan mode.

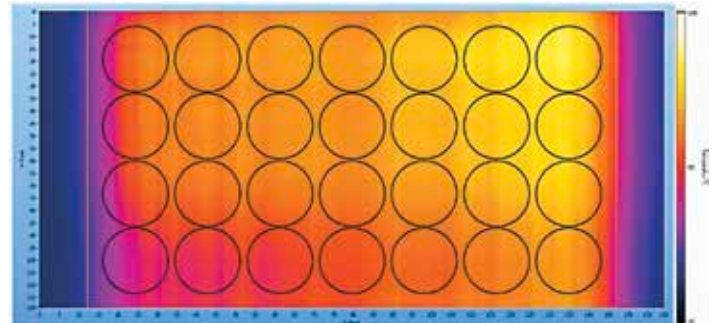

Photography courtesy of Toolvision GmbH

## Innovation Takes Root in California

By Conor Carlin, Editor

*[Editor's Note: this article has been modified from an earlier version that was published in *Plastics Engineering*]*

"Innovation Takes Root" is a biannual conference hosted by NatureWorks, developer of the Ingeo PLA polymer and the Vercet lactide chemistry platforms. This year marked the sixth such gathering, held in San Diego from September 10-12 with over 250 attendees from 27 countries. Billed as "the advanced biomaterials forum", it was clear that the organizers put some serious thought into developing a dynamic event that offered more than the typical range of technical powerpoint presentations. A blend of workshops, fireside chats, seminars and keynotes ensured an engaged audience over the three-day period in a location that wasn't limited to windowless, air-conditioned meeting rooms. Major topics included the continued evolution of the Ingeo platform, circular economy principles, regulatory and legislative developments related to bio-based plastics, PLA use in additive manufacturing, and new developments in single-serve capsules (they're not just for coffee anymore). Speakers came from throughout the supply chain, including a bevy of NatureWorks scientists, executives from major brands including Danone and Electrolux, and consultants from The Ellen MacArthur Foundation, whose iconic slides from "The New Plastics Economy" were featured throughout the event.

### Defining the Bioeconomy

According to the US Department of Energy, in the United States the bioeconomy has the potential to produce at least 1 billion dry tons of biomass annually by 2030.<sup>1</sup> As the numbers now suggest, the bioeconomy is about much more than biofuels, with over 2500 products certified by the USDA. Commercialized bioproducts include biobased polymers, adhesives, chemicals and pharmaceuticals. Across the Atlantic, bioeconomy is defined by the European Commission as "the production of renewable biological resources and the conversion of these resources and waste streams into value added products, such as food, feed, bio-based products and bioenergy." The EU has assigned a budget of €80bn as

part of the "Horizon 2020" research and development program to drive innovation and commercialization of new biobased products for the bioeconomy. In this context, the NatureWorks Ingeo platform is proof that the bioeconomy works and is profitable in a market-based economy. Of course, sustained investment was required along the way as NatureWorks' long-term partner Cargill has shown.

### Language, Definitions, and Regulations

Central to the discussion about the bioeconomy is the taxonomy of materials involved. As the sector has matured and become more specialized, it is becoming clear that definitions are finding acceptance and agreement across industries. In the realm of specifications, ASTM 6400 and 6868 provide guidance. As with many bureaucratic regulations, these rules are valuable for their specificity, not their brevity. ASTM 6400 covers "Standard Specification for Labeling of Plastics Designed to be Aerobically Composted in Municipal or Industrial Facilities" and ASTM 6868 covers "Standard Specification for Labeling of End Items that Incorporate Plastics and Polymers as Coatings or Additives with Paper and Other Substrates Designed to be Aerobically Composted in Municipal or Industrial Facilities".

Melissa Romero from Californians Against Waste (CAW) provided a crisp synopsis of the challenges facing regulators, producers and consumers when labeling biobased materials such as PLA. California is at the forefront of climate-based legislation with several bills making their way through the halls of power in Sacramento. CA SB 1383 creates targets to achieve 40% reduction in methane emissions by 2030, primarily through the reduction of organic food waste. CA SB 1335 requires food facilities in state-owned facilities to use reusable, recyclable or compostable food service packaging, but it is "material neutral", meaning PLA is one of several acceptable polymer-based materials that can be used by CalRecycle which is responsible for adopting the program by 2021.

CAW's mission is to identify, notify and report on matters related to the public interest on the topic of waste. They help to develop clear rules and to combat misleading environmental claims, while engaging in the process of rebuilding public faith, credibility and value in the appropriate use of truthful and meaningful environmental claims. Garcia provided details on several legal actions that resulted in actions against producers and brand

owners where products such as plastic water bottles were inaccurately promoted as containing bio-based materials and additives. Though the settlements were relatively low (between \$1MM - \$1.5MM), the actions also led to injunctions against the offending companies from selling their products to California consumers and sent a strong signal to those who would test the limits of environmental advertising laws.

Global certification programs for compostability continue to evolve with specifications, test methods, guides and best practices becoming more standardized and harmonized across jurisdictions. Organizations such as the Biodegradable Products Institute (BPI) and USDA in the United States, and DIN Certco and TUV Austria-Belgium (formerly Vinçotte) in Europe, include certification of sustainable feedstocks such as corn, beets, cassava, sugar cane as well as other C6 sugars from stover, wood and bagasse. In all cases, the percentage levels of bio-based content are central to receiving certification. Bureaucratic as it may sound, certification carries the weight of authenticity and requires standards auditing and third-party approval. ISCC Systems (Cologne, Germany) is a global sustainability certification system for all feedstocks that manages the criteria and mandatory requirements for accurate and traceable certification of biobased content. By auditing the entire chain of custody from farm to product, ISCC provides mass-balance book-keeping that allows converters and brand owners to avoid misstatements about the true volumes of biobased materials made and sold.

### **A Cornucopia of New Products**

As an event, Innovation Takes Root (or ITR, for short) functions as a kind of smorgasbord for materials development and new product introductions where masterbatch producers rub shoulders with extrusion manufacturers, thermoformers meet product designers from the worlds of coffee and food packaging, and additive manufacturing companies confab with resin producers, NatureWorks foremost among them. One topic that engaged a majority of the value chain was new product development for the food service industry. According to figures from the Green Restaurant Association cited by Nicole Whitemann, applications development engineer at NatureWorks, 39 billion pieces of disposable cutlery are produced each year, only 1% of which is recycled. Coated paper cups are included in these figures and though they

are generally easy to recycle with other fiber sources, the use of PE or PLA can impact the level of biodegradable content which affects the decision to recycle or compost the items. There is a growing portfolio of examples and case studies illustrating just how much savings can be found via effective waste diversion programs. Marquee programs from the London Olympics to major sporting stadia have shown significant strides toward making zero waste a reality. Whitemann announced the launch of Ingeo 1102, a new PLA extrusion coating grade that exhibits improved performance through optimization of polymer design. Compared to PE, PLA has lower melt strength and higher viscosity which creates manufacturing challenges such as high neck-in and draw resonance that limits line speeds. Ingeo 1102 is designed to balance some of the conflicting attributes of PLA to deliver a more stable web with good adhesion and good seal strength while improving flow and penetration into paperboard to reduce coating weights and improve cup sealing range.<sup>2</sup>

Beyond new Ingeo-based product introductions from NatureWorks, several leading players in the biopolymer ecosystem announced developments in additive masterbatches such as impact modifiers for transparency, slip and antiblock agents for coefficient of friction changes, and barrier films for enhanced shelf life applications. Sukano (Duncan, SC) presented data on a variety of additives including their transparent modifier S633 as used in thermoformed packaging. This nucleating masterbatch forms many small nucleation sites which increases the speed of crystallization. A melt strength enhancer improves IV and mechanical properties while retaining transparency. Using LDR of 1-3% is shown to reduce brittleness without affecting temperature resistance. For injection molding grades of PLA, Sukano S687-D, an opaque impact modifier, improves elasticity and toughness for high-stress applications when used at 10-30% dosage rates.



*Clarity is key for fresh food packaging. (Photo: C. Carlin)*

## Capsules for Coffee and More

Retail volumes of coffee capsules continue to grow, though the rate of growth is set to decline from a high of 20% YoY in 2012 to a projected 5% in 2021. With approximately 380MM tons of capsules produced in in 2018, this global phenomenon appears to be reaching saturation point. In 2015, Lavazza, the Italian coffee company, launched the first compostable coffee capsule but did not achieve market recognition or acceptance due to a variety of factors include regulatory uncertainty and costs. More than 30% of the production cost of capsules is related to packaging, with compostable materials costing more than aluminum or polymer-based alternatives. For manufacturers, the traditional process is now familiar and optimized, with capex fully depreciated.<sup>3</sup>



PLA coffee capsules can be made via thermoforming or injection molding. (Photo C. Carlin)

Two Italian companies have picked up where Lavazza left off and developed new PLA-based compostable coffee capsules, both injection and thermoformed, that meet the strict requirements of Europe's espresso connoisseurs. Critical to success is the customer's organoleptic

experience, even though the average consumer might not have an appreciation for the finer details of oxygen and water vapor transmission rates. Mitaly (Baranzate, Italy), a division of Imper Spa, uses co-injection technology to replicate the most popular capsule shapes on the market. Co-injection allows for the barrier layer to be integrated into the primary process while retaining robust construction and dimensional stability. In addition to coffee, the company offers compostable beverage capsules for soft drinks, fruit beverages, and sport / energy drinks, all using the Ingeo polymer platform. Mitaly's capsules are 100% compatible with Nescafe Dolce Gusto machines, though the company has also created their own "all in one" multi-beverage system for hot and cold drinks.

Flo (Verona, Italy) is a pan-European food service product manufacturer who recently announced a breakthrough in CPLA thermoformed coffee capsules under the name Gea. At ITR, they recounted their story of converting from PP to CPLA, including in-depth studies of Ingeo grades and the critical role that polymer crystallization plays in developing a material that meets consumer, manufacturing and environmental needs. All the raw materials used to produce GEA are certified for industrial composting system according to global standards such as EN 13432 and ASTM D6400.<sup>4</sup>

## "We Cannot Recycle Our Way Out of This"

A paradox of sorts exists for PLA producers and users: what do we do with the products at the end-of-life? Though the material meets the requirements found in EN 13432 and can be composted in industrial facilities, it is an acknowledged fact that we do not yet have adequate infrastructure for large scale composting. Compounding this challenge is resin code #7 – "other" – where PLA is lumped with many other polymers including ABS, PC and multilayer films. For a polymer to be given its own resin code, there must be 400MM lbs of production for 3 consecutive years. In addition, 40 state legislatures must be lobbied so that the code can be created and written into law. Because PLA is a still a relative newcomer to the family of thermoplastic polymers, it has not yet reached the levels of production that can trigger the necessary recycling mechanisms. Indeed, throughout the event, it was clear that the product life cycle for new polymers is measured in generations, not years.

Mats Linder, a Sweden-based consultant who has worked with the Ellen Macarthur Foundation, laid out the basic



principles of the new plastics economy. Not everything is designed for recycling or re-use, so we must develop new strategies to transform the global plastics (packaging) market. In the year 2015, over 78MM tons of plastic packaging was produced, with 14% collected for recycling, 40% sent to landfill, and 32% leaked into the environment. This is a staggering number that represents an incredible loss of valuable resources when you consider plastics' ability to be re-purposed in one form or another. Only 2% of all plastics packaging was used in a closed-loop recycling model, mildly suggesting that there is room for improvement. The Macarthur Foundation calculates that this waste represents \$40bn in negative externalities. Linder offered that the circular economy requires a systemic change, forcing us all to use materials in a restorative and regenerative way. He outlined three basic principles which, if broadly implemented, would catalyze a new plastics economy: design out waste and pollution; keep products and materials in use for as long as possible; regenerate natural systems.

### Partnership, Invention, Passion

ITR 2018 was also a party of sorts for NatureWorks' new CEO, Rich Altice. Previously of PolyOne, Altice took the helm of NatureWorks in April 2018 as the company reached a milestone of 2bn pounds of Ingeo biopolymer sold. His closing keynote offered a broad perspective on the challenges facing the plastics industry and where the NatureWorks Ingeo and Vercet platforms reside in the market life cycle. With over 1MM metric tons now sold, PLA is still in the growth phase, having "crossed the chasm" and now inspires a large and growing ecosystem of entrepreneurs, inventors and brand majors. "It takes time to get it right," said Altice. "But we've come a long way since 1989, when it all started, and we will continue to develop the sustainable solutions the world needs."

Few would argue that plastics have made incredible contributions to modern society, yet polymer-based materials face an uncertain future, with regulatory bans coming into effect in many jurisdictions. PLA, after almost 30 years of development, has still not reached the industrial scale where it can displace fossil-based alternatives, but what ITR illustrated is that Ingeo is being used in an increasing number of applications across multiple industries. Its properties are being tailored to achieve specific outcomes and it is being blended with other materials such as PHA for enhanced environmental

benefits. Combined with end-of-life questions and a lack of political action to drive required investments in infrastructure, we could be looking at another generation of research, investment and innovation before the corn-based plastic achieves the elusive #8 PLA resin code on the bottom of our coffee capsules. But as the ancients told us, it was the tortoise that won the race in the end.

1. [https://www.energy.gov/sites/prod/files/2017/09/f37/bioeconomy\\_by\\_the\\_numbers\\_infographic.pdf](https://www.energy.gov/sites/prod/files/2017/09/f37/bioeconomy_by_the_numbers_infographic.pdf)
2. "Rethinking the Paper Cup", Nicole Whitemann, NatureWorks, presentation at ITR 2018
3. "Growth and Market Validation of Compostable Coffee Capsules", Fabio Osculati, presentation at ITR 2018
4. "Gea – A New Generation of Coffee Capsule", presentation at ITR 2018 |

## Have an idea for an article?

- Article length: 1,000 - 2,000 words. Look to past articles for guidance.
  - Format: .doc or .docx
- Artwork: hi-res images are encouraged (300 dpi) with appropriate credits.

Send all submissions to:  
Conor Carlin, Editor [cpcarlin@gmail.com](mailto:cpcarlin@gmail.com)

**TPS LLC**  
THE ONLY WAY TO BUY PARTS FOR YOUR THERMOFORMER

Bushings Heaters & T/C Q/C Clamp Frame Lubrication

[www.thermoformerparts.com](http://www.thermoformerparts.com)

Chain Rails Pin Chain Pins & Bushings Peening Hammer

**1-800-722-2997**

## Thermoforming Company Embodies Triple Bottom Line with Environmental Certifications

Merrill's Packaging, a designer and thermoformer of medical packaging, has passed the California State Green Business/San Mateo County Green Business audit, certifying the company for another three years. The company continues to find new ways to reduce water and power consumption as well as innovative ways to recycle, reuse, and repurpose materials. Leslie Lopez, vice president of finance, reports that the company has been certified since 2009 in the county.

"In 2009, we underwent certification audits by multiple agencies including, the County of San Mateo, The City of Burlingame, The Water Department, and PG&E, our utility. We were the first plastics company to be certified in the State of California. In 2015 we were re-certified by a different agency at the county level, completing an all new audit requiring all new "Green Improvements". All county certifications are automatically recognized as CA State Green Companies. Recently, the certification process has grown to include 5 States (CA, WA, AZ, CO, and IL). You can go the website [www.greenbusinessca.org](http://www.greenbusinessca.org) for more information."

"We've doubled in size over the previous six-year period, and yet we've reduced our garbage," she says. "We are a 65,000-sq-ft operation, and we only have one garbage bin that's emptied once per week."

The company is also audited for its water and power usage. "Over the last four-year period, business has increased by 20%, yet our power use has stayed the same."

Merrill's has installed a battery pack system (which Lopez says looks like a row of lockers) that is charged overnight and sits in reserve. The system was supplied by STEM, an AI-powered energy intelligence firm that helps companies reduce energy consumption through smart meters and virtual energy storage systems. To reduce Merrill's impact on the community's power grid during peak use periods (typically 2 to 6 pm), the facility "pulls power from the battery pack system, which reduces the amount of energy

used from the grid," Lopez explains. The system is then "refilled in the middle of the night," when power use in the community is lower.

Employees are also made aware of their power usage thanks to a screen inside the plant that displays how much energy is being used in real time, which encourages employees to avoid downtime or idle equipment time.

Packaging is also examined for savings. "We work with customers to recycle the packaging we use to ship trays to them," says Lopez. "We use Gaylord-style boxes which feature plastic tops and bottoms, and corrugated walls with a plastic additive, up to 300 times."

Other efforts include: reducing the use of plastic water bottles as much as possible, as well as using reusable plastic water glasses and pitchers for customer visits; using copy paper with at least 50% recycled content; composting used paper towels; reimbursing employees for public transit; providing charging stations for electric cars and areas to park bikes; and recycling practically everything. "If we don't use it here in a closed-loop process, we send it to our plastic recycler separately from the garbage and mixed plastic."

Lopez, who's been with Merrill's for 25 years, says that when she first decided to seek the certification for her company years ago, "we were already doing a lot and being responsible, so I just took charge."

But she admits, "It wasn't easy to pass the audit. I wasn't composting, so they got on me for it. But since we serve the medical industry, we don't want pests, so we don't compost food. We have, however, started to compost yard waste and paper towel waste. Recently we have been encouraged by our ISO13485 auditor (who also audits ISO14000 Environmental Management) to go for the ISO14000 certification. He was impressed with our continuing efforts to improve our operation's effect on the environment."

"Because we are a medical packaging facility, we want people to understand there's no way there will be any contamination of their trays," adds Andy D'Esposito, Sales Manager for the company. "We follow Good Manufacturing Practices, so that's not an issue." |

# GN

Thermoforming Equipment



## GN800

Form/Cut/Stack model

*Are you still  
producing  
too much waste?*

*Do you want  
to reduce  
production costs?*

*If yes  
contact us at  
[gn@gncanada.com](mailto:gn@gncanada.com)*

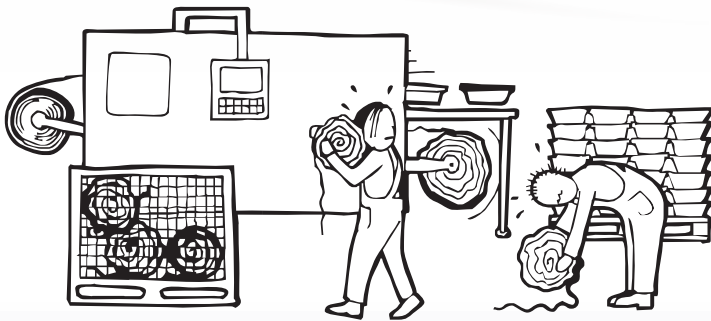

[www.gncanada.com](http://www.gncanada.com)

## SPE Council Report

SPE Council convened in Charleston, SC for the Fall 2018 meeting. At the beginning of proceedings, President Brian Grady called for a moment of silence to honor the passing of several distinguished SPE members.

Clear and relevant governance is the foundation of a well-run society and SPE continues to refine its policies and by-laws. Several items were amended and approved during Council thanks to the diligent leadership of Councilor Bruce Mulholland.

All presentations and data discussed during Council meetings are available on The Chain on Leadership Lane. We encourage councilors to remind all their respective chapter members that The Chain is our primary method of communication for SPE business.

### Financial Review & CEO Report

CEO Farrey presented a financial report that covered Society finances through June 30, 2018. Since then, the July 2018 financial report has been made available (see below). The operational performance was strong, with costs trending downward despite increased headcount and salary increases at SPE HQ. The information systems overhaul will produce \$200k in net savings annually when older contracts are unwound.

The SPE financial investment portfolio has declined and

remains behind budget. Farrey explained that SPE's financial portfolio continues to be conservative, targeting 6% annual return.

Farrey presented an update on the initial impact of Council's decision to stay with the old chapter dues system after having implemented a new software program. The current way of doing business results in higher costs (\$5k one-time charge, \$6k monthly accounting fees) while reducing efficiencies such as enabling auto-renewal for members. After much discussion, both in Council and during recess, VP of Sections, Scott Eastman, brokered a compromise that allows chapters to lock-in the amount of pass-through funds for two years at the level received on June 30, 2018 while embracing the new software system. Of course, this number can increase as chapters attract and retain new members.

### New Programs & Initiatives

SPE continues to build programs that deliver value for members. Director of Member Experience, Sue Wojnicki, presented an overview of a new content strategy, including licensed learning courses from the Institute of Packaging Professionals (IOPP) titled, "Fundamentals of Plastics Packaging Technology". SPE-developed webinars, which are free for SPE members and \$199 for non-members, are being rolled out through the remainder of 2018 covering topics such as artificial intelligence and plastics in the automotive sector. To support this and other programs, a new marketing program manager has been hired to

	Jul-18	Month	Month Budget	YTD	YTD Budget	Annual Budget
<b>REVENUES</b>						
Membership/HQ		\$167,226	\$159,333	\$1,233,501	\$1,115,334	\$1,912,001
Foundation		\$44,096	\$38,625	\$211,874	\$270,375	\$463,500
HQ Events		\$6,500	\$833	\$791,289	\$884,333	\$888,500
Supported Events		(\$6,794)	\$0	\$101,946	\$112,500	\$348,500
<b>Total Revenues</b>		<b>\$211,028</b>	<b>\$198,791</b>	<b>\$2,338,610</b>	<b>\$2,382,542</b>	<b>\$3,612,501</b>
<b>EXPENSES</b>						
Membership/HQ		\$209,850	\$243,013	\$1,657,221	\$1,701,094	\$2,916,161
Foundation		\$7,716	\$49,125	\$195,661	\$343,872	\$589,495
HQ Events		\$41	\$157	\$558,172	\$714,998	\$715,781
Supported Events		(\$1,890)	\$0	(\$4,208)	\$8,450	\$22,600
<b>Total Expenses</b>		<b>\$215,717</b>	<b>\$292,295</b>	<b>\$2,406,846</b>	<b>\$2,768,414</b>	<b>\$4,244,037</b>
<b>RESULTS</b>						
Operational result		(\$4,689)	(\$93,504)	(\$68,236)	(\$385,872)	(\$631,536)
Investment/Interest		\$8,364	\$33,417	\$2,052	\$233,917	\$401,000
Wiley Deferred revenue		\$12,500	\$12,500	\$87,500	\$87,500	\$150,000
<b>Total Result</b>		<b>\$16,175</b>	<b>(\$47,587)</b>	<b>\$21,316</b>	<b>(\$64,455)</b>	<b>(\$80,536)</b>

create and improve processes for member acquisition and retention.

A new mentor program has been launched. SPE members can sign up to be a mentor, a mentee, or both. This development comes in response to previous ideas from councilors and members about taking advantage of the knowledge and skills of our 22,000-strong community of plastics professionals.

In addition to new programs, the new IT infrastructure continues to create benefits make life easier for volunteer leaders such as live membership reporting where membership chairs can access reports at any time. In addition, SPE can now help Chapters process credit cards for incidental payments received for things like newsletter ads, sponsorships, etc. Through a simple online payment gateway form, Chapters may now accept credit card payments and HQ will clear the transaction and remit the revenue back to the Chapter.

SPE has discontinued the use of paid conference calling systems which results in a cost savings of ~3K/month, Chapters can take advantage of new, free, better systems such as Zoom and staff will offer support of Zoom if questions arise. Pinnacle Awards forms can now be completed entirely online whereas before they had to be printed, completed by hand, scanned and emailed to SPE. The SPE Online Technical Library now contains over 14,000 items. With improved search functionality, this is a valuable tool for chapters to promote the content created by their members at conferences or other events. Each chapter is responsible for deciding which content is suitable for inclusion. Instructions for uploading can be found on the main SPE website: Content > Leadership Resources > Leadership Documents. SPE will provide additional guidance in the following weeks.

### **Chapter Insurance Program**

Following recent discussions on The Chain that clarified the need of each chapter to have its own insurance coverage, Farrey announced that a global agreement has been negotiated by SPE to offer insurance for all chapter board members for \$450/yr starting on October 1, 2018. This amount is significantly less than previous programs where the average cost to the chapters was \$1200/yr. Chapters must have the following in order to be insured using the program developed by HQ: 1) bylaws are on file

with SPE HQ; 2) a current roster with all board members, all of whom must be SPE members must be provided to SPE HQ; 3) financial forms (IRS 990 and annual report) must be on file with SPE. A webinar covering all details will be hosted by SPE at 11h00 EST on September 27, 2018. Details about the program are posted at [www.4spe.org/chapterinsurance](http://www.4spe.org/chapterinsurance). SIGs and student chapters are exempt as they are covered by SPE. Chapters that already have coverage are encouraged to talk to Farrey directly about the transition.

### **SPE Foundation Report**

SPE Foundation Director, Eve Vitale, announced that the Foundation Annual Report will be available at ANTEC 2019 in Detroit. Vitale reviewed multiple initiatives underway through the Foundation including increased advocacy efforts with PLASTICS for both workforce development and recycling infrastructure funding; PlastiVan outreach programs with Kettering University, Baylor University, SPE Divisions including Thermoforming and Composites, and a virtual classroom seminar with students in Australia in partnership with the AUS/NZ Section.

### **2019 Executive Board Elections**

There are 3 open positions on the SPE Executive Board. Terms begin March 17, 2019. Elections will be held beginning in January 2019 for the following positions:

- President-Elect: 1-yr term, 3-yr commitment
- VP Events: 3-yr term
- VP Young Professionals: 3-yr term

Past-President Al-Zubi reviewed the timeline and mechanisms for the election process. All details are posted to Leadership Lane.

The next Council meeting will be held via conference call on December 13. A one-hour meeting is expected, and the primary purpose of the meeting will be to review the budget.

Respectfully submitted,



Conor P. Carlin  
EB Secretary

VP Marketing & Communication |

## Remembering Two Thermoforming Industry Pioneers

By Lesley Kyle, CMP

Photography by Dallager Photography

The Thermoforming Industry lost two luminaries in recent months: Arthur Buckel and Stanley Rosen.



Art Buckel

A major in mathematics at San Diego State College, Art Buckel taught mathematics and astronomy while serving on active duty at the Army Artillery Survey School in Fort Sill, Oklahoma. Art decided to go into business for himself and later founded Specialty Manufacturing, Inc. (SMI) in San Diego, California, in 1972.

By the mid 1980s, SMI had become one of the most sophisticated thermoforming and fabrication companies in the U.S. Art designed both commercial and military components, assemblies, electronic hardware, packaging, and containers. In his role as Vice President of Engineering, Art wore many hats. He designed and built parts, assemblies and tooling fixtures, and molds for heavy gauge and roll-fed products. In addition, Art worked closely with the sales team and developed and delivered proposals to prospective clients. As part of the sales process, Art directed costing and estimating procedures. He also managed Specialty Manufacturing's tooling and manufacturing operations.

After selling Specialty Manufacturing in 1990, Art joined Bill McConnell as an associate of the McConnell Co., Inc., where he advised numerous global companies on the topics of problem solving, plant analysis, parts troubleshooting, in-plant personnel training, new facility layout and design, and new product and tooling development. Art provided expert testimony in numerous legal cases pertaining to material failures, product failures (including loss of life), and patent infringements. He also lectured at San Diego State University and University of California at San Diego, and organized and presented numerous seminars on thermoforming technology, production procedures and tooling.

As an active member of the SPE Thermoforming Division Board of Directors, Art was presented with the Division's Outstanding Achievement Award in 1996. He was named Thermoformer of the Year in 1999 and was the first individual to be elected to Emeritus Director of the Board in 2011.

Arthur Buckel passed away on October 30, 2018: he was 84 years old.



Stan Rosen

Using his G.I. Bill, Stan Rosen attended and graduated from the University of Buffalo with a B.S. in Mechanical Engineering. After gaining some experience as a machine designer, he joined Tronomatic Corp., a plastics machinery builder in New York City, as an engineer.

A client ordered a machine to heat seal a plastic blister to a card, and this machine became popular in the packaging industry. The blister sealers attracted the attention of numerous vacuum forming machinery firms, and Stan was encouraged to design and build steel rule die cutters. Stan patented a self-contained air hydraulic intensifier power unit which provided the necessary force for steel rule die cutting of large area plastics shots. This line of sealers and die cutters complemented thermoforming machines, and Tronomatic soon developed its own vacuum former line.

With experience in designing complete thermoforming systems, Stan established his own firm, Thermoform Machinery and Mold Systems Corp., in 1965. The company served niche portions of the thermoforming industry with machinery, molds and dies. In the late 1960s, much of the custom thermoforming industry converted production from manual steel rule die cutting to inline form and trim for short to medium runs.

There was an urgent need to keep tooling costs to a minimum for small quantities. Stan patented a universal mold and steel rule press buildup that allowed multiple use for a wide variety of shot layouts. When many thermoforming firms converted production from vacuum to pressure forming, demand grew for a prototype R&D pressure former. Hydrotrim Corp. was founded and built the "Labform" thermofomer, which duplicated all of the available processes on production equipment.

An accomplished author, Stan penned many articles and compilations on thermoforming. He authored the book, *Thermoforming, Improving Process Performance*, published in 2002. Stan also wrote, *A History of the Growth of the Thermoforming Industry: 1930-1950*, which is currently published on the Division's website ([thermoformingdivision.com](http://thermoformingdivision.com)). He served as Chair of the SPE Thermoforming Division's Board of Directors (1988-1990) and was named SPE Thermoformer of the Year in 1991.

Stan Rosen passed away on August 16: he was 91 years old. |

# 2018 THERMOFORMING DIVISION ORGANIZATIONAL CHART

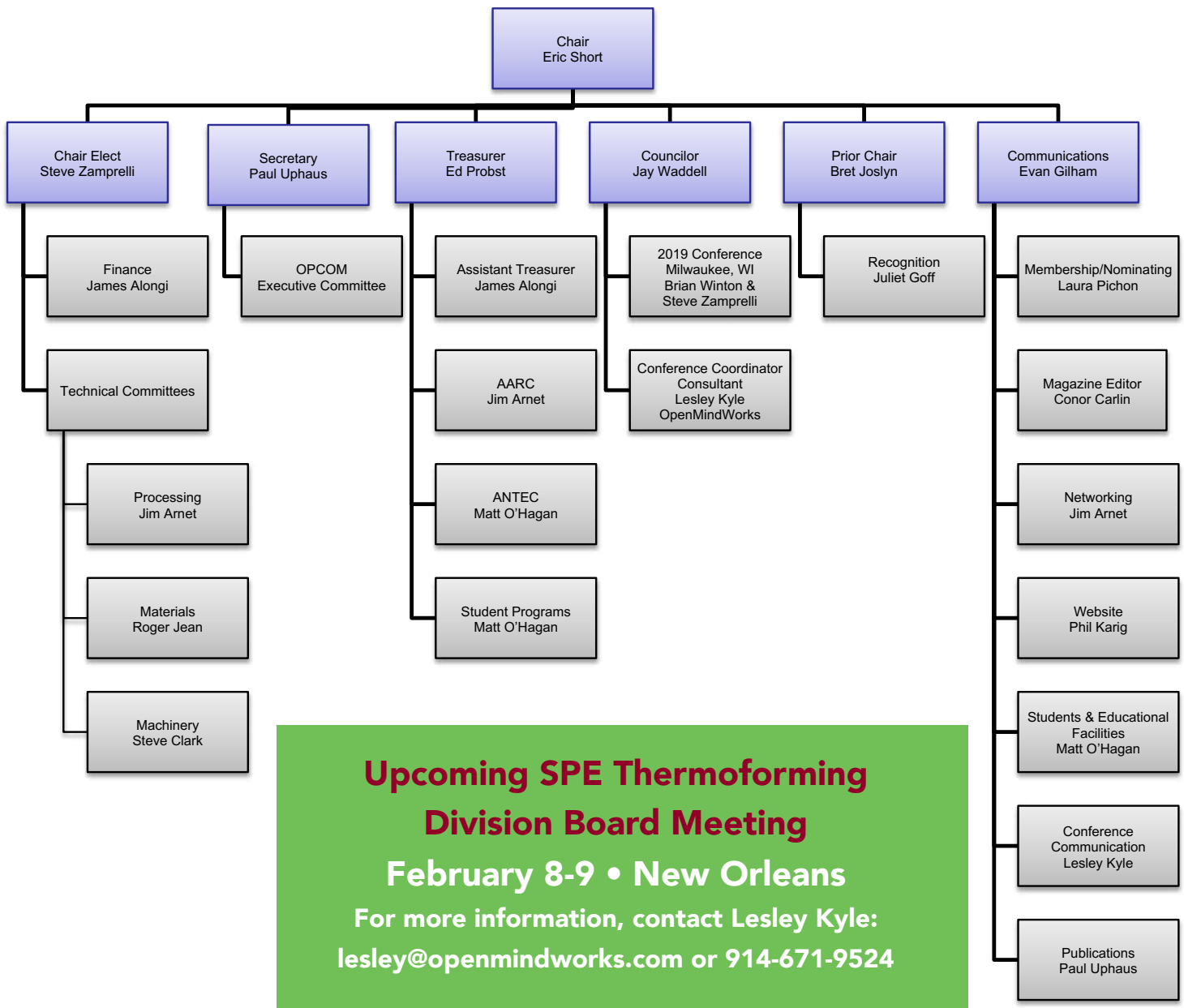

## Thermoforming Division Membership **Benefits**

- Access to industry knowledge from one central location: [www.thermoformingdivision.com](http://www.thermoformingdivision.com).
- Subscription to Thermoforming Quarterly, voted "Publication of the Year" by SPE National.
- Exposure to new ideas and trends from across the globe.
- New and innovative part design at the Parts Competition.
- Open dialogue with the entire industry at the annual conference.
- Discounts, discounts, discounts on books, seminars and conferences.
- For managers: workshops and presentations tailored specifically to the needs of your operators.
- For operators: workshops and presentations that will send you home with new tools to improve your performance, make your job easier and help the company's bottom line.

**JOIN TODAY!**

## **MACHINERY COMMITTEE**

James Alongi  
MAAC Machinery  
590 Tower Blvd.  
Carol Stream, IL 60188  
T: 630.665.1700  
jalongi@maacmachinery.com

Steven Clark (Chair)  
Monark Equipment  
PO Box 335  
4533 S. Garfield Road  
Auburn, MI 48611  
T: 989.662.7250  
sclark@monark-equip.com

Brian Golden  
SencorpWhite  
400 Kidd's Hill Road  
Hyannis, MA 02601  
T: 508.771.9400  
bgolden@sencorpwhite.com

Travis Kieffer  
Plastics Unlimited, Inc.  
303 1st St. N.W.  
Preston, IA 52069  
T: 563.589.4752  
TravisK@plasticsunlimited.com

Brian Winton  
Lyle Industries, Inc.  
4144 W. Lyle Road  
Beaverton, MI 48612  
T: 989.435.7714 x 32  
bwinton@lyleindustries.com

## **MATERIALS COMMITTEE**

Juliet Goff  
Kal Plastics  
2050 East 48th Street  
Vernon, CA 90058-2022  
T: 323.581.6194  
juliet@kal-plastics.com

Roger P. Jean (Chair)  
Rowmark/PMC  
PO Box 1605  
2040 Industrial Drive  
Findlay, OH 45840  
T: 567.208.9758  
rjean@buypmc.com

Phillip Karig  
Mathelin Bay Associates LLC  
11939 Manchester Road #148  
Saint Louis, MO 63131  
T: 314.630.8384  
karig@mathelinbay.com

Ian Munnoch  
MSA Components, Inc.  
202 S. Douglas Street  
Dodgeville, WI 53533  
T: 812.322.5080  
imunnoch@msacomponents.com

Matt O'Hagan  
LyondellBasell  
7674 Park Meadow Lane  
West Bloomfield, MI 48324  
T: 248.760.8590  
matt.ohagan@lyondellbasell.com

Laura Pichon  
Ex-Tech Plastics  
PO Box 576  
11413 Burlington Road  
Richmond, IL 60071  
T: 847.829.8124  
lpichon@extechplastics.com

Ed Probst  
Probst Plastics Consulting  
P.O. Box 26365  
Wauwatosa, WI 53226  
T: 414.476.3096  
ed.probst@probstplastics.com

Eric Short  
SIMONA PMC  
2040 Industrial Drive  
Findlay, OH 45840  
T: 567-525-4924  
eric.short@simona-pmc.com

Dan Sproles  
Sproles Business Consulting  
5210 Canton Street  
South Bend, IN 60071  
T: 574-747-7997  
dan@sprolesbusinessconsulting.com

Paul Uphaus  
Primex Plastics  
4164 Lake Oconee Drive  
Buford, GA 30519  
T: 1.800.935.9272  
puphaus@primexplastics.com

## **PROCESSING COMMITTEE**

Jim Arnet (Chair)  
Hagans Plastics Co.  
121 W. Rock Island Road  
Grand Prairie, TX 75050  
T: 972.974.3516  
jarnet@hagansus.com

Robert Browning  
McConnell Company  
P.O. Box 450633  
Atlanta, GA 31145  
T: 770.939.4497  
robert@thermoformingmc.com

Evan Gilham  
Productive Plastics  
103 W. Park Drive  
Mt. Laurel, NJ 08054  
T: 856-778-4300, x225  
EGilham@productivecompanies.com

Bret Joslyn  
Joslyn Manufacturing  
9400 Valley View Road  
Macedonia, OH 44056  
T: 330.467.8111  
bret@joslyn-mfg.com

Stephen Murrill  
Profile Plastics  
65 S. Waukegan  
Lake Bluff, IL 60044  
T: 847.604.5100 x29  
smurrill@thermoform.com

Jay Waddell  
Plastics Concepts & Innovations  
1127 Queensborough Road  
Suite 102  
Mt. Pleasant, SC 29464  
T: 843.971.7833  
jwaddell@plasticconcepts.com

Steve Zamprelli  
Formed Plastics, Inc.  
297 Stonehinge Lane  
Carle Place, NY 11514  
T: 516.334.2300  
s.zamprelli@formedplastics.com

## **DIRECTORS EMERITI**

Jim Armor  
Armor & Associates  
16181 Santa Barbara Lane  
Huntington Beach, CA 92649  
T: 714.846.7000  
jimarmor@aol.com

Lola Carere  
302 Sable Trace Ct.  
Acworth, GA 30102-7617  
T: 770.883.7055  
carerelola@comcast.net

Richard Freeman  
Freetech Plastics Inc.  
2211 Warm Springs Court  
Fremont, CA 94539  
T: 510.651.9996  
rfree@freetechplastics.com

Steve Hasselbach  
CMI Plastics  
222 Pepsi Way  
Ayden, NC 28513  
T: 252.746.2171  
steve@cmiplastics.com

Donald Hylton  
McConnell Company  
646 Holyfield Highway  
Fairburn, GA 30213  
T: 678.772.5008  
don@thermoformingmc.com

Roger Kipp  
Roger C. Kipp Consulting  
3C Owens Landing Court  
Perryville, MD 21903  
T: 717.521.9254  
srkipp@msn.com

Gwen Mathis  
6 S. Second Street SE  
Lindale, GA 30147  
T: 706.346.2786  
gmathis224@aol.com





# DRIVEN BY **INNOVATION**



There is no substitute for the experience we've gained by rolling up our sleeves and working through improvements at every stage of thermoforming technology for over six decades. From process design through putting high-output machinery on the floor, innovation is in our DNA.



*Creators of world-class machinery,  
tooling and automation systems*  
**RUN WITH CONFIDENCE**



These sponsors enable us to publish *SPE Thermoforming Quarterly*

- Advanced Extruder Technologies ..... 5
- Brown Machinery ..... 41
- CMT Materials..... 8
- Formed Plastics..... 14
- GN Thermoforming Equipment..... 35
- Illig ..... 13
- Irwin Research & Development ..... 15
- MAAC Machinery..... 25
- O.M.G. SRL..... 27
- Polyscope ..... 7
- Portage Casting & Mold ..... 42
- Premier Material Concepts..... Inside Back Cover
- Profile Plastics. .... 25
- PTi Extruders..... Inside Front Cover
- Sekisui Polymer Innovations ..... Back Cover
- Senoplast..... 14
- Siemens ..... 11
- Solar Products..... 8
- Stiles..... 42
- Thermoformer Parts Suppliers..... 33
- Tooling Tech ..... 25
- Toolvision..... 17
- TSL ..... 21

**WORLD-CLASS  
MACHINERY  
SOLUTIONS FOR  
COMPOSITE,  
HONEYCOMB &  
NON-FERROUS  
METALS**

**YOUR SUCCESS IS OUR BUSINESS**  
616.698.7500 | [www.stilesaero.com](http://www.stilesaero.com)

**STILES | HC**  
A HOMAG COMPANY

Quality Thermoform Molds Since 1972

Portage Casting & Mold, Inc.  
2901 Portage Road, Portage, WI  
1-800-356-5337 ♦ [www.pcmwi.com](http://www.pcmwi.com)

**REDUCE! REUSE! RECYCLE!**



Hello!

Meet Sam.

SIMONA PMC Quality & Material  
Engineering Manager- Since 2015

**"I love finding solutions for  
unique material challenges..."**

At PMC, we're constantly working to  
improve processes— and that gives us the  
opportunity to have a direct, positive impact  
with our customers!"

– Samantha Stacy

**MORE THAN JUST SHEET, EXPERIENCE THE SIMONA PMC DIFFERENCE!**

Our team of extrusion professionals and material experts will help you  
find the best material for your demanding applications.

ABS | TPO | Acrylic | ASA | PC/ABS | Soft-touch & MORE!

**REALIZE THE SIMONA PMC DIFFERENCE**

877.289.7626 // [sales@simona-pmc.com](mailto:sales@simona-pmc.com) // [simona-pmc.com](http://simona-pmc.com)





# Get everything you need in no time flat.

You make ideas real by giving them shape and form. As your partner, we're committed to supporting you by manufacturing customizable thermoplastics of the highest quality in low MOQs with short lead times.

Plus no stress. We get it, and make sure you do, too.

Learn more at [sekisui-spi.com](https://sekisui-spi.com)

**SEKISUI | SPI**

**KYDEX**  
THERMOPLASTICS

**ALLEN**  
THERMOPLASTICS

**designLab**

**FSTLab**